

PWLNR/L

AUSSENDREHEN - ISO P
EXTERNAL TURNING - ISO P

216 - 219

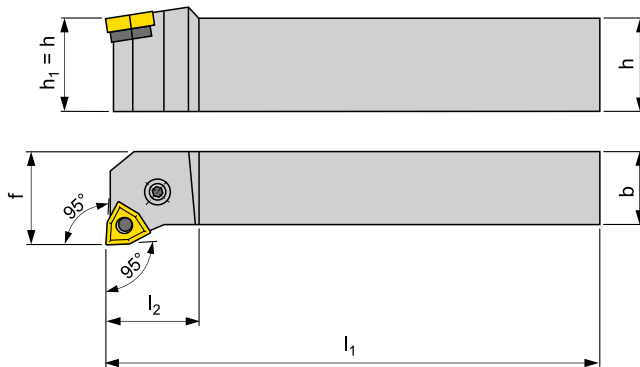
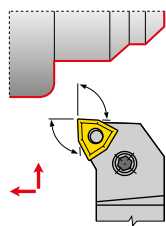

γ_s° - Werkzeug-Orthogonalspanwinkel / tool orthogonal rake
 λ_s° - Werkzeug-Neigungswinkel / tool cutting edge inclination

KLEMMHALTER ZUM AUSSENDREHEN / TOOLS FOR EXTERNAL TURNING

| ISO | R/L | Abmessungen / Dimensions | | | | | | | λ_s° | γ_s° | kg | Ersatzteile Spare parts | WSP Inserts |
|---------------------|-----|--------------------------|----|----|-------|-------|--|--|-------------------|------------------|------|----------------------------|----------------|
| | | $h=h_1$ | b | f | l_1 | l_2 | | | | | | | |
| PWLNR/L 1616 H 0604 | ●/● | 16 | 16 | 20 | 100 | 20 | | | -6 | -6 | 0,22 | PW11 | WNM. 0604.. |
| PWLNR/L 2020 K 0604 | ●/● | 20 | 20 | 25 | 125 | 20 | | | -6 | -6 | 0,40 | PW10 | WNM. 0604.. |
| PWLNR/L 2020 K 08 | ●/● | 20 | 20 | 25 | 125 | 22 | | | -6 | -6 | 0,40 | PW22 | WN.. 0804.. |
| PWLNR/L 2525 M 0604 | ●/● | 25 | 25 | 32 | 150 | 20 | | | -6 | -6 | 0,70 | PW10 | WNM. 0604.. |
| PWLNR/L 2525 M 08 | ●/● | 25 | 25 | 32 | 150 | 22 | | | -6 | -6 | 0,70 | PW20 | WN.. 0804.. |
| PWLNR/L 3225 P 08 | ●/● | 32 | 25 | 32 | 170 | 22 | | | -6 | -6 | 1,00 | PW20 | WN.. 0804.. |

Alle Abmessungen [mm] / All dimensions [mm]

ERSATZTEILE / SPARE PARTS

* Empfohlene Torxschraube - siehe Seite 380-381 / See pages 380-381 for recommended screw torques

| Typ Type | Unterlage Shim | Kniehebel Clamping lever | Spannschraube* Clamp. screw* | Rohrstift Tubular rivet | Montagedorn Mount. taper plug | Schlüssel Key |
|-------------|-------------------|-----------------------------|---------------------------------|----------------------------|----------------------------------|------------------|
| PW10 | WNU 060308 | PU 01 | US 34 (M6x19,0) | NT 04 | MT 04 | HXK 3 |
| PW11 | WNU 060308 | PU 01 | US 46 (M6x13,2) | NT 04 | MT 04 | HXK 3 |
| PW20 | WNU 080312 | PU 02 | US 35 (M8x22,5) | NT 05 | MT 05 | HXK 4 |
| PW22 | WNU 080312 | PU 02 | US 42 (M8x21,0) | NT 05 | MT 05 | HXK 4 |