



Brand of NTN Group

Technical data

SUCFL210N

Bearing units



Stainless steel cast housing, stainless steel insert ball bearing with socket set screws, seal with slinger, food grease

KIT CONTENT

SUC210, SFL210N

VISUAL (S)

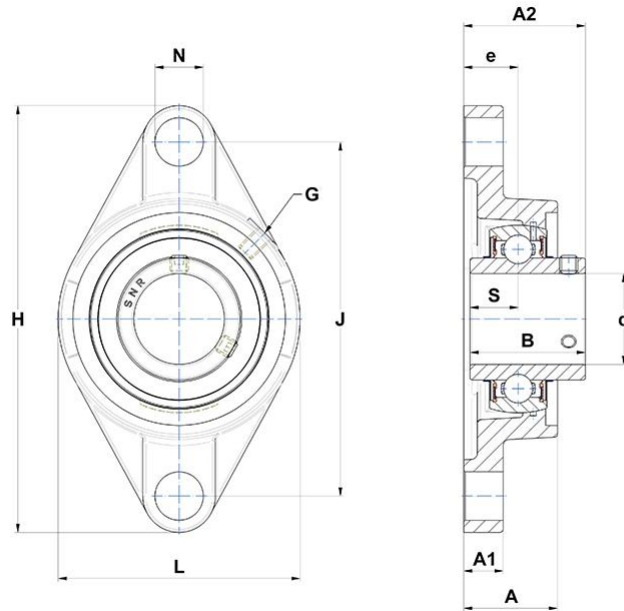

PRODUCT DEFINITION

Brand	SNR
A - Housing height	39 mm
A1 - Housing foot height / flange height	16 mm
A2 - Total height from mounting surface	54,6 mm
B - Width of Inner Ring	51,6 mm



NTN Europe

1 rue des Usines · BP 2017 · 74010 Annecy Cedex · France · Tel. +33 (0)4 50 65 30 00
S.A. au capital de 322 639 919 € · RCS ANNECY B 325 821 072 · Id. Fiscale : FR 48 325 821 072
SIRET 325 821 072 00015 · Code APE 2815 Z · Code NACE 28.15

PRODUCT DEFINITION

d - Shaft diameter	50 mm
e - Distance mounting surface to bearing center	22 mm
G - Grease fitting	M6x1
H - Housing length, width or diameter	190 mm
J - Mounting holes distance	157 mm
L - Housing width / diameter	115 mm
N - Mounting hole dimension	17,5 mm
S - Distance front side/bearing centre	19 mm

PRODUCT PERFORMANCE

C - Dynamic load rating	35000000 mN
C0 - Static load rating	23100000 mN
Operating temperature min.	253,15 °K
Operating temperature max.	373,15 °K

OTHER FEATURES

Mass	2,27 kg
Recommended tightening torque for set screw	18.7 N-m

