

P Panel Nut (QPL) D38999 Series III & IV

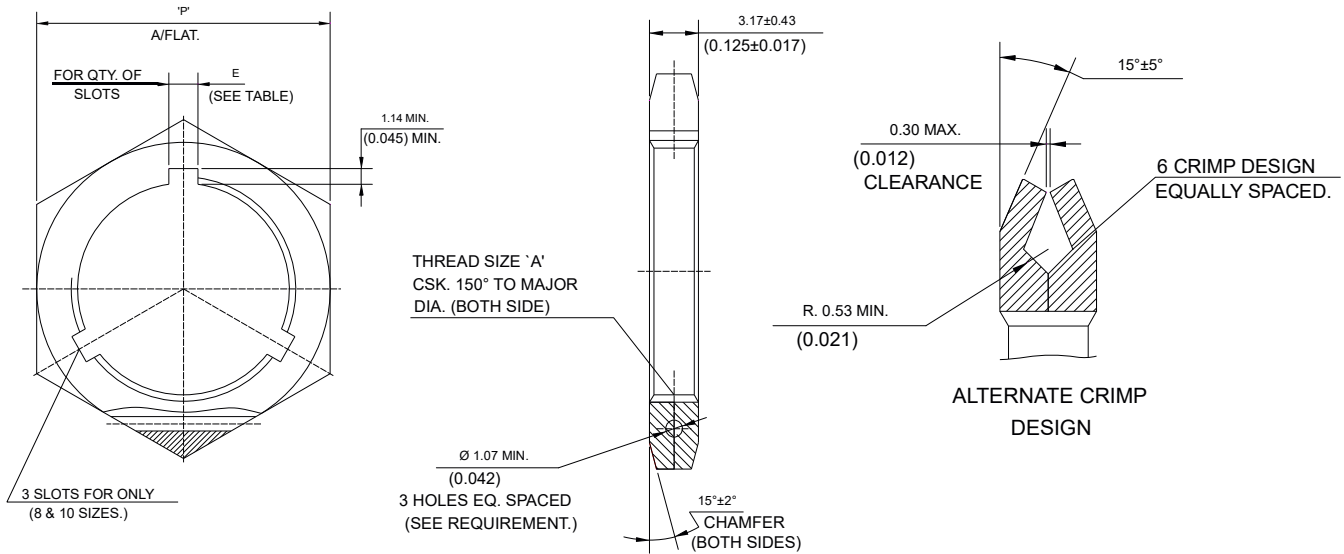

Dimensions

Dash No.	Shell size		'A' Thread Size	Modified Minor Dia	P Hex.
	Ser-III	Ser-IV			
1	09	---	M17X1-6H	16.04/16.15	24.0 21.82
2	11	---	M20X1-6H	19.07/19.15	27.0 24.99
3	13	11	M25X1-6H	---	32.0 29.77
4	15	13	M28X1-6H	---	36.0 32.91
5	---	15	M31X1-6H	---	41.0 39.26
6	17	---	M32X1-6H	---	37.0 36.12
7	---	17	M34X1-6H	---	41.0 39.25
8	19	---	M35X1-6H	---	41.0 39.25
9	21	19	M38X1-6H	---	46.0 42.47
10	23	21	M41X1-6H	---	50.0 45.61
11	25	23	M44X1-6H	---	51.23 49.25
12	---	25	M47X1-6H	---	55.0 53.54

Requirements:

Material - Panel Nut : Machined Aluminium Alloy
Used in Connector : MIL-DTL-38999, Series III, & IV (Jam Nut Receptacle)

Ordering Information: (QPL)

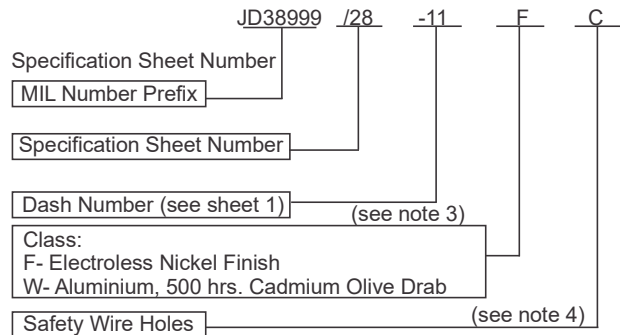

Ordering Information: (Proprietary)

