

Surge protection device - TTC-6P-3-HF-F-12DC-PT-I - 1065314

Please be informed that the data shown in this PDF Document is generated from our Online Catalog. Please find the complete data in the user's documentation. Our General Terms of Use for Downloads are valid (<http://phoenixcontact.com/download>)



Surge protection, consisting of protective plug and base element, with integrated status indicator for three signal wires with common reference potential. For HF applications and telecommunications interfaces without supply voltage. Indirect grounding via gas-filled surge arrester.



Key Commercial Data

Packing unit	1 pc
GTIN	
GTIN	4055626725789
Weight per Piece (excluding packing)	38.000 g
Custom tariff number	85363010
Country of origin	Germany
Note	Made to Order (non-returnable)

Technical data

Dimensions

Height	105.8 mm
Width	6.2 mm +0.1 mm
Depth	100 mm (incl. DIN rail 7.5 mm)

Ambient conditions

Ambient temperature (operation)	-40 °C ... 85 °C
Ambient temperature (storage/transport)	-40 °C ... 85 °C
Permissible humidity (operation)	5 % ... 95 %
Altitude	≤ 4000 m (amsl (above mean sea level))
Degree of protection	IP20

General

Housing material	PBT
Flammability rating according to UL 94	V-0
Color	traffic grey A RAL 7042

Surge protection device - TTC-6P-3-HF-F-12DC-PT-I - 1065314

Technical data

General

	light grey RAL 7035
Mounting type	DIN rail: TH 35 - 7.5 mm
Type	DIN rail module, two-section, divisible
Direction of action	Line-Line & Line-Signal Ground/Shield & optional Signal Ground/Shield-Earth Ground

Protective circuit

IEC test classification	C1
	C2
	C3
	D1
Nominal voltage U_N	12 V DC
Maximum continuous voltage U_C	15 V DC
	10 V AC
Rated current	600 mA (56 °C)
Operating effective current I_C at U_C	$\leq 100 \mu\text{A}$
Residual current I_{PE}	$\leq 1 \mu\text{A}$
Nominal discharge current I_n (8/20) μs (line-line)	5 kA
Nominal discharge current I_n (8/20) μs (line-earth)	5 kA
Nominal discharge current I_n (8/20) μs (line-signal ground)	5 kA
Pulse discharge current I_{imp} (10/350) μs (line-line)	0.5 kA
Pulse discharge current I_{imp} (10/350) μs (line-earth)	0.5 kA
Pulse discharge current I_{imp} (10/350) μs (line-signalground)	0.5 kA
Total discharge current I_{total} (8/20) μs	10 kA
Voltage protection level U_p (line-line)	$\leq 145 \text{ V}$ (C1 - 1 kV/500 A)
	$\leq 260 \text{ V}$ (C2 - 10 kV / 5 kA)
	$\leq 25 \text{ V}$ (C3 - 25 A)
	$\leq 30 \text{ V}$ (C3 - 100 A)
Voltage protection level U_p (line-earth)	$\leq 750 \text{ V}$ (C1 - 1 kV/500 A)
	$\leq 750 \text{ V}$ (C2 - 10 kV / 5 kA)
	$\leq 1.1 \text{ kV}$ (C3 - 25 A)
	$\leq 1.2 \text{ kV}$ (C3 - 100 A)
Voltage protection level U_p (line-signalground)	$\leq 80 \text{ V}$ (C1 - 1 kV/500 A)
	$\leq 95 \text{ V}$ (C2 - 10 kV / 5 kA)
	$\leq 25 \text{ V}$ (C3 - 25 A)
	$\leq 30 \text{ V}$ (C3 - 100 A)
Voltage protection level U_p static (line-line)	$\leq 40 \text{ V}$ (C1 - 1 kV/500 A)
	$\leq 95 \text{ V}$ (C2 - 10 kV / 5 kA)
Voltage protection level U_p static (line-earth)	$\leq 40 \text{ V}$ (C1 - 1 kV/500 A)
	$\leq 95 \text{ V}$ (C2 - 10 kV / 5 kA)
Voltage protection level U_p static (line-signalground)	$\leq 750 \text{ V}$ (C1 - 1 kV/500 A)

Surge protection device - TTC-6P-3-HF-F-12DC-PT-I - 1065314

Technical data

Protective circuit

	≤ 750 V (C2 - 10 kV / 5 kA)
Response time t_A (line-line)	≤ 1 ns
Response time t_A (line-signalground)	≤ 1 ns
Response time t_A (line-earth)	≤ 100 ns
Input attenuation aE, sym.	typ. 0.3 dB (≤ 8.7 MHz / 150 Ω)
Input attenuation aE, asym.	typ. 0.3 dB (≤ 10.5 MHz / 150 Ω)
Cut-off frequency f_g (3 dB), sym. in 150 Ohm system	typ. 60 MHz
Cut-off frequency f_g (3 dB), asym. (GND) in 150 Ohm system	typ. 60 MHz
Capacity (line-line)	typ. 32 pF
Capacity (line-signalground)	typ. 32 pF
Resistance per path	1.65 Ω ±20 %
Max. required back-up fuse	630 mA (FF)
Impulse durability (line-line)	C1 - 1 kV / 500 A C2 - 10 kV / 5 kA C3 - 100 A
Impulse durability (line-earth)	C1 - 1 kV / 500 A C2 - 10 kV / 5 kA C3 - 100 A D1 - 500 A
Impulse durability (line-signalground)	C1 - 1 kV / 500 A C2 - 10 kV / 5 kA C3 - 100 A D1 - 500 A
Pulse reset time (line-line)	≤ 30 ms
Pulse reset time (line-earth)	≤ 30 ms
Pulse reset time (line-signalground)	≤ 30 ms

Additional technical data

Max. total discharge current $I_{total\ max}$ (8/20) μs	20 kA (1x)
---	------------

Connection data

Connection method	Push-in connection
Stripping length	8 mm
Conductor cross section flexible	0.2 mm ² ... 2.5 mm ²
Conductor cross section solid	0.2 mm ² ... 4 mm ²
Conductor cross section AWG	24 ... 12

Standards and Regulations

Standards/specifications	IEC 61643-21 2000 + corrigendum 2001 + A1:2008, modified + A2:2012
	EN 61643-21 2001 + A1:2009 + A2:2013

Environmental Product Compliance

REACH SVHC	Lead 7439-92-1
------------	----------------

Surge protection device - TTC-6P-3-HF-F-12DC-PT-I - 1065314

Technical data

Environmental Product Compliance

China RoHS	Environmentally Friendly Use Period = 50 years
	For details about hazardous substances go to tab "Downloads", Category "Manufacturer's declaration"

Drawings

Diagram

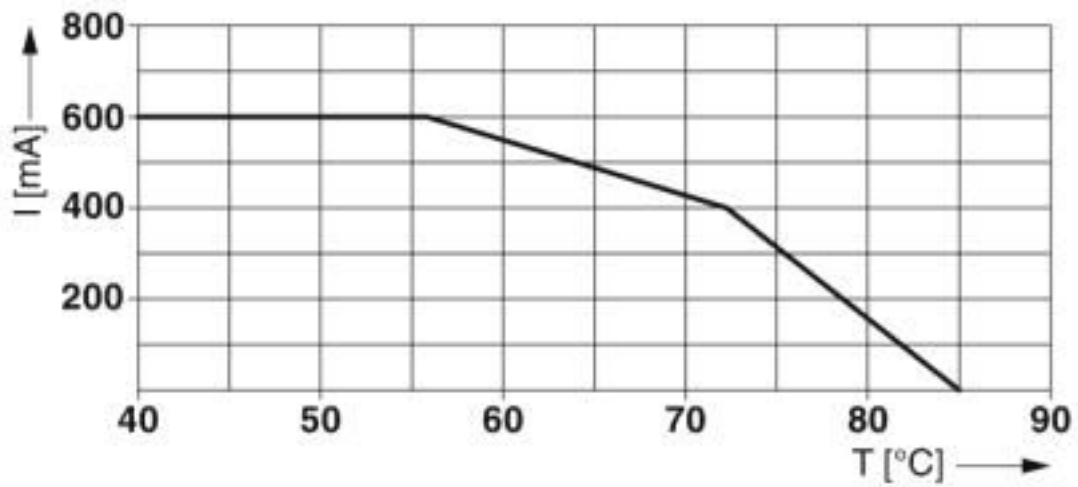

Dimensional drawing

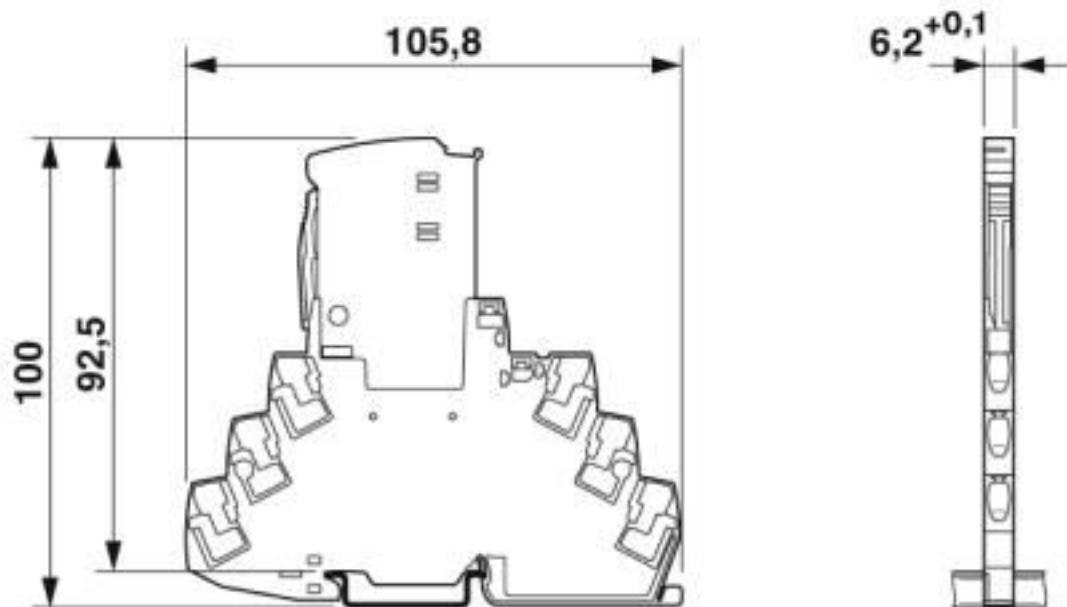

Surge protection device - TTC-6P-3-HF-F-12DC-PT-I - 1065314

Circuit diagram

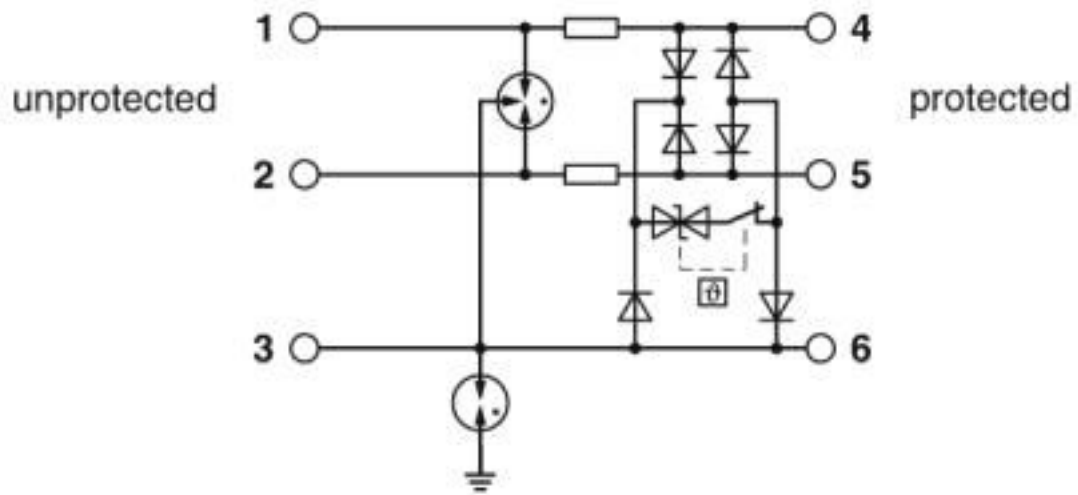

Classifications

eCl@ss

eCl@ss 10.0.1	27130807
eCl@ss 6.0	27130800
eCl@ss 7.0	27130807
eCl@ss 8.0	27130807
eCl@ss 9.0	27130807

ETIM

ETIM 5.0	EC000943
ETIM 6.0	EC000943
ETIM 7.0	EC000943

Approvals

Approvals

Approvals

UL Listed

Ex Approvals

UL Listed / cUL Listed / cULus Listed

Approval details

Surge protection device - TTC-6P-3-HF-F-12DC-PT-I - 1065314

Approvals

UL Listed



<http://database.ul.com/cgi-bin/XYV/template/LISEXT/1FRAME/index.htm>

FILE E 138168

Accessories

Accessories

End block

End clamp - CLIPFIX 35-5 - 3022276



Quick mounting end clamp for NS 35/7,5 DIN rail or NS 35/15 DIN rail, with marking option, with parking option for FBS...5, FBS...6, KSS 5, KSS 6, width: 5.15 mm, color: gray

Labeled terminal marker

Zack Marker strip, flat - ZBF 6 CUS - 0825027



Zack Marker strip, flat, Strip, can be ordered: Strip, white, labeled according to customer specifications, mounting type: snap into flat marker groove, for terminal block width: 6.2 mm, lettering field size: 5.15 x 6.15 mm, Number of individual labels: 10

Zack Marker strip, flat - ZBF 6,QR:FORTL.ZAHLEN - 0808765



Zack Marker strip, flat, Strip, white, labeled, Printed vertically: consecutive numbers 1 ... 10, 11 ... 20, etc. up to 91 ... 100, mounting type: snap into flat marker groove, for terminal block width: 6.2 mm, lettering field size: 5.15 x 6.15 mm, Number of individual labels: 10

Marker pen

Marker pen - X-PEN 0,35 - 0811228



Marker pen without ink cartridge, for manual labeling of markers, labeling extremely wipe-proof, line thickness 0.35 mm

Terminal marking

Surge protection device - TTC-6P-3-HF-F-12DC-PT-I - 1065314

Accessories

Zack Marker strip, flat - ZBF 6:UNBEDRUCKT - 0808710



Zack Marker strip, flat, Strip, white, unlabeled, can be labeled with: PLOTMARK, CMS-P1-PLOTTER, mounting type: snap into flat marker groove, for terminal block width: 6.2 mm, lettering field size: 5.15 x 6.15 mm, Number of individual labels: 10

Zack Marker strip, flat - ZBF 6/WH-100:UNBEDRUCKT - 0808736



Zack Marker strip, flat, Strip, white, unlabeled, can be labeled with: PLOTMARK, CMS-P1-PLOTTER, mounting type: snap into flat marker groove, for terminal block width: 6.2 mm, lettering field size: 5.15 x 6.15 mm, Number of individual labels: 10

Additional products

Remote signaling set - TTC-6-FMRS-PT - 2907811



Module set for the optical monitoring and floating remote signaling of neighboring surge protective devices of the TERMITRAB complete product range.

Shield connection - SSA 3-6 - 2839295



Shield fast connection for 3 ... 6 mm cable diameter. Potential connecting cable: 200 mm, 1 mm², color: black

Shield connection - SSA 5-10 - 2839512



Shield fast connection for 5 ... 10 mm cable diameter. Potential connecting cable: 200 mm, 1 mm², color: black

Spare parts

Surge protection device - TTC-6P-3-HF-F-12DC-PT-I - 1065314

Accessories

Surge protection plug - TTC-6P-3-HF-12DC-I-P - 2907846



Surge protection plug with integrated status indicator on the module for three signal wires. For HF applications.
Nominal voltage: 12 V DC