

MRIG series geared hybrid stepper motors

The combination of the MRIG gearhead and HS series hrid stepper motor provides excellent performance ogether with high resolution. The units are therefore deally suited to a wide variety of high performance instrumentation and light industrial applications. When operated in the preferred half step drive mode the units provide a choice of resolutions from 2,000 to 200,000 steps per resolution as shown below.



HS or HSX motors may be driven from 4 phase Uni-polar or 2 phase Bi-polar drive circuits and are available with matched drives, power supplies and controllers to enable a complete motion control system to be readily constructed.

Geared Stepper Motor	Ratio	Steps per rev. at output	Holding Torque (Ncm)	Max Working Torque (Ncm)	Typical Working torque (Ncm)
MRIG02.....	5:1	2,000	32	29	22
-G06	25:2	5,000	81	72	54
-G11 using 17HS	25:1	10,000	146	130	98
-G17 stepper motor	50:1	20,000	293	260	195
-G22	100:1	40,000	500	400	348
-G23	125:1	50,000	600	400	400
-G27	250:1	100,000	700	600	600
-G34	500:1	200,000	700	700	700

Geared Stepper Motor	Ratio	Steps per rev. at output	Holding Torque (Ncm)	Max Working Torque (Ncm)	Typical Working torque (Ncm)
MRIG02.....	5:1	2,000	90	65	43
-G06 using 23HS-030	25:2	5,000	225	162	108
-G11 stepper motor	25:1	10,000	400	293	195
-G17	50:1	20,000	500	400	390
-G22	100:1	40,000	700	400	400

Geared Stepper Motor	Ratio	Steps per rev. at output	Holding Torque (Ncm)	Max Working Torque (Ncm)	Typical Working torque (Ncm)
MRIG02.....	5:1	2,000	137	97	72
-G06 using	25:2	5,000	250	243	180
-G11 23HS104	25:1	10,000	400	400	325
-G17 23HS108	50:1	20,000	500	400	400
-G22 &	100:1	40,000	700	400	400
-G23 23HS(X)202	125:1	50,000	700	500	500
-G27 stepper motors	250:1	100,000	700	700	700
-G34	500:1	200,000	700	700	700

Geared Stepper Motor	Ratio	Steps per rev. at output	Holding Torque (Ncm)	Max Working Torque (Ncm)	Typical Working torque (Ncm)
MRIG02..... using	5:1	2,000	150	150	108
-G06 23HS304	25:2	5,000	250	250	250
-G11 23HS309	25:1	10,000	400	400	400
-G17 stepper motors	50:1	20,000	500	400	400

Note: Steps/rev. figures quoted above are obtained when the motor is operated in HALF STEP

Geared hybrid stepper motors

MRIG - 17HS series

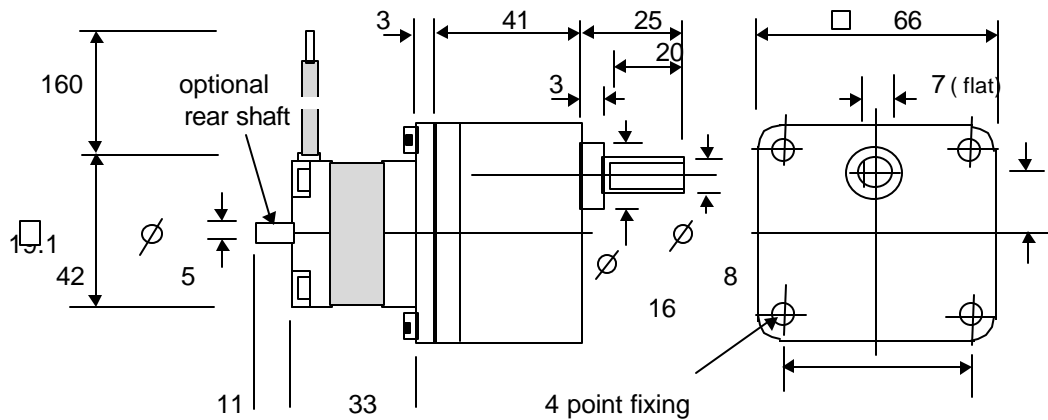

17 HS Motor Options

	17HS-006	17HS-020
Number of phase	4	4
Current per phase (Amps)	0.26	1
Phase resistance (Ohms)	36	2
Phase Inductance (mH)	17	1.1
Rotor inertia (Kgcm ²)	0.019	0.019
Step rate @ typical torque (half steps per sec.) (half steps per second) using supply rail	1,500	7,500
Driver type	4 phase Uni-polar	4 phase Uni-polar
Driver Model number	TM162C	TM162C

MRIG - 23HS/Hsx

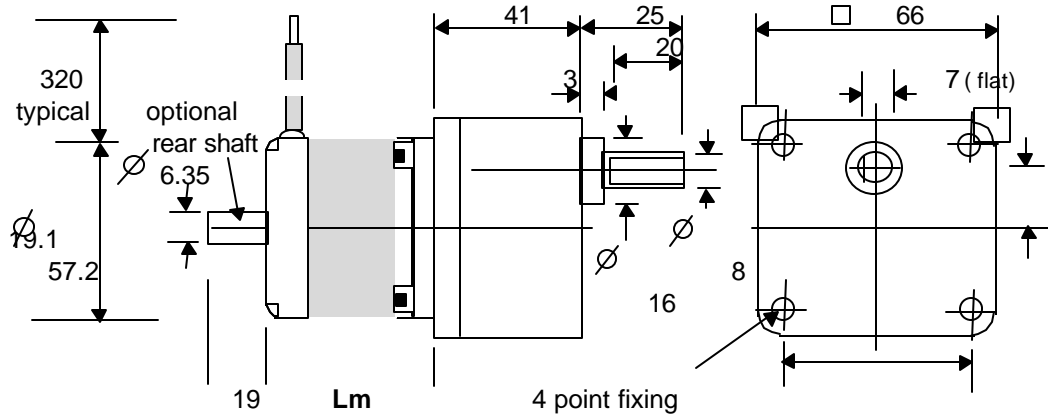

23HS series Motor Options:

	23HS-030	23HS-104	23HS-108	23HS-202	23HS-304	23HS-309
Number of phase	4	4	4	4	4	4
Motor Length Lm (mm)	38.7	50.8	50.8	56	76.2	76.2
Current per phase (Amps)	1.5	2	3.9	1	2	4.7
Phase resistance (Ohms)	1.6	1.1	0.37	5	1.1	0.37
Phase Inductance (mH)	1.6	2.0	0.59	9.5	5.7	0.73
Rotor inertia (Kgcm ²)	0.077	0.115	0.115	0.135	0.239	0.239
Step rate @ typical torque (half steps per second) Using supply rail	4,000	6,000	12,000	3,400	3,750	12,000
Driver type	4 phase Uni-polar	4 phase Uni-polar	2 phase Bi-polar	4 phase Uni-polar	4 phase Uni-polar	2 phase Bi-polar
Driver Model number	TM162C	TM162C	PM546	TM162C	TM162C	TM164C