

577226 ADNGF-100-20-PPS-A Compact cylinder - Series till 05-2023

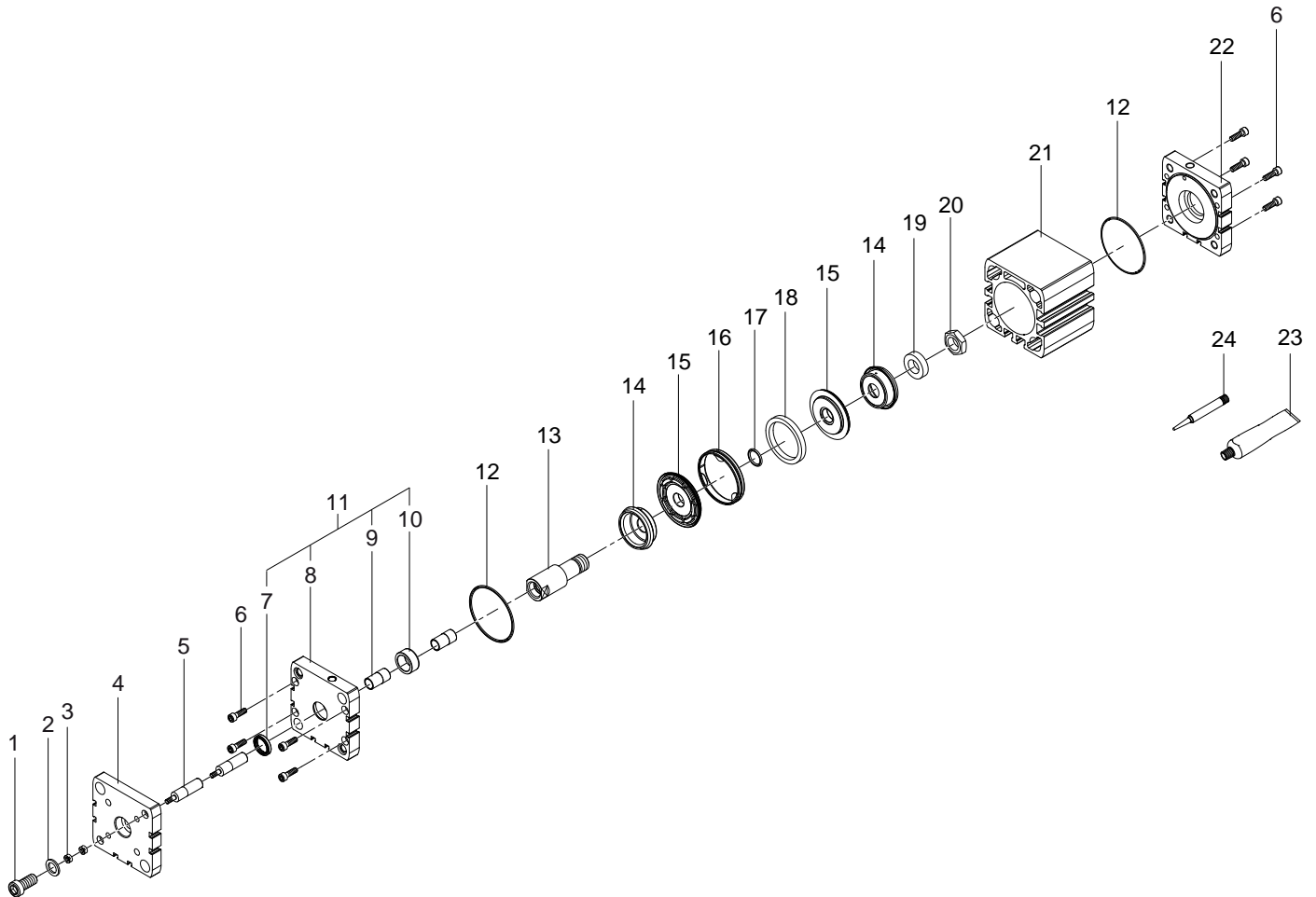

## 577226 ADNGF-100-20-PPS-A Compact cylinder - Series till 05-2023

Pos.	Part no.	Type	Note	Qty.	Unit
A	673628	ADN-100-P-A Set of wearing parts	Spare parts: 7, 12, 15, 16, 17, 24 Attention, please order position 14 as well	1	PC
1	223363	DIN 6912-M12X25-8.8 Socket head screw	Tightening torque 27.2 Nm / 20.1 lbf ft Use locking compound. See position 24	1	PC
2	213486	DIN 433-13 Disc		1	PC
3	252678	DIN 546-M5-ST Slotted nut	Tightening torque 5.9 Nm / 4.4 lbf ft Use locking compound. See position 24	2	PC
4	665001	ADNGF-100 Moment compensator	No longer available. Please order from product series R5 the components with position nos. 3+4+5.	1	PC
5	668743	ADNGF-80/100-X- Guide rod	No longer available. Please order from product series R5 the components with position nos. 3+4+5. When ordering please specify the stroke (see type plate) Grease using during assembly. See position 23	2	PC
6		ISO 4762-M6X25-A2-70 Socket head screw	Not available Tightening torque 9 Nm / 6.6 lbf ft	8	PC
7	359748	WIFC1-20X25X4,6-TPE-U Wiper seal	Grease using during assembly. See position 23	1	PC
8		ADNGF-100:CO Bearing cap	Not available separately, see position 11	1	PC
9		ADNGF-100 Collar end bearing	Not available separately, see position 11	2	PC
10		ADN-80/100 Bearing	Not available separately, see position 11	1	PC
11	8153578	ADNGF-100/-PPS Bearing cap module		1	PC
12		B-100X1,5-N-NBR70 O-ring ISO3601	Not available separately, see position A Grease using during assembly. See position 23	2	PC
13	683600	ADN-100- - Piston rod	When ordering please specify the configuration (see type plate)	1	PC
14	1724489	ADN-100-PPS Buffer sleeve	centering tool will be required PN 2585245	2	PC
15		BA-K01D-100-02 Piston module	Not available separately, see position A	2	PC
16		BA-K01F-100 Guiding band	Not available separately, see position A	1	PC
17		B-14X1,5-N-NBR75 O-ring ISO3601	Not available separately, see position A Grease using during assembly. See position 23	1	PC
18	4760183	96,8X85,3X4,9BA-K01M-100 Ring magnet		1	PC
19	668949	DIN 7349-15 Disc		1	PC
20	204153	DIN 439-B-M14X1,5-04 Hex nut	Tightening torque 45.5 Nm / 33.6 lbf ft Use locking compound 8181258 CYBERBOND TI 7680	1	PC
21		ADNGF-100-X- Cylinder barrel	Not available Grease using during assembly. See position 23	1	PC
22	1954962	ADN-100:CO End cap		1	PC
23	684474	LUB-KC1 SILIKONFREI 20ML Lubricating grease		1	PC
24	8181256	CYBERBOND TM44 TB1ML Adhesive bonding agent		1	PC