



# LTC2901

## ABSOLUTE MAXIMUM RATINGS (Notes 1, 2, 3)

V <sub>1</sub> , V <sub>2</sub> , V <sub>3</sub> , V <sub>4</sub> , V <sub>PG</sub> .....	-0.3V to 7V	Operating Temperature Range	
RST (LTC2901-1/LTC2901-3) .....	-0.3V to 7V	LTC2901-1C/LTC2901-2C/	
RST (LTC2901-2/LTC2901-4) .....	-0.3V to (V <sub>2</sub> + 0.3V)	LTC2901-3C/LTC2901-4C .....	0°C to 70°C
COMPX .....	-0.3V to 7V	LTC2901-1I/LTC2901-2I/	
CWT, WDI, WDO .....	-0.3V to 7V	LTC2901-3I/LTC2901-4I .....	-40°C to 85°C
V <sub>REF</sub> , CRT, TOL .....	-0.3V to (V <sub>CC</sub> + 0.3V)	Storage Temperature Range .....	-65°C to 150°C
Reference Load Current (I <sub>VREF</sub> ) .....	±1mA	Lead Temperature (Soldering, 10 sec) .....	300°C
V <sub>4</sub> Input Current (-ADJ Mode) .....	-1mA		

## PACKAGE/ORDER INFORMATION

<p>GN PACKAGE 16-LEAD PLASTIC SSOP T<sub>JMAX</sub> = 125°C, θ<sub>JA</sub> = 110°C/W</p>	<b>ORDER PART NUMBER</b>  LTC2901-1CGN LTC2901-2CGN LTC2901-1IGN LTC2901-2IGN	<p>GN PACKAGE 16-LEAD PLASTIC SSOP T<sub>JMAX</sub> = 125°C, θ<sub>JA</sub> = 110°C/W</p>	<b>ORDER PART NUMBER</b>  LTC2901-3CGN LTC2901-4CGN LTC2901-3IGN LTC2901-4IGN		
	<b>GN16 PART MARKING</b>		<b>GN16 PART MARKING</b>		
	29011 29012 29011I 29012I			29013 29014 29013I 29014I	
	<b>Order Options</b> Tape and Reel: Add #TR Lead Free: Add #PBF Lead Free Tape and Reel: Add #TRPBF Lead Free Part Marking: <a href="http://www.linear.com/leadfree/">http://www.linear.com/leadfree/</a> Consult LTC Marketing for parts specified with wider operating temperature ranges.				

## ELECTRICAL CHARACTERISTICS

The ● denotes the specifications which apply over the full operating temperature range, otherwise specifications are at T<sub>A</sub> = 25°C. V<sub>CC</sub> = 5V, unless otherwise noted. (Notes 3, 4)

SYMBOL	PARAMETER	CONDITIONS	MIN	TYP	MAX	UNITS	
V <sub>RT50</sub>	5V, 5% Reset Threshold 5V, 10% Reset Threshold	V <sub>1</sub> Input Threshold	●	4.600	4.675	4.750	V
			●	4.350	4.425	4.500	V
V <sub>RT33</sub>	3.3V, 5% Reset Threshold 3.3V, 10% Reset Threshold	V <sub>1</sub> , V <sub>2</sub> Input Threshold	●	3.036	3.086	3.135	V
			●	2.871	2.921	2.970	V
V <sub>RT30</sub>	3V, 5% Reset Threshold 3V, 10% Reset Threshold	V <sub>2</sub> Input Threshold	●	2.760	2.805	2.850	V
			●	2.610	2.655	2.700	V
V <sub>RT25</sub>	2.5V, 5% Reset Threshold 2.5V, 10% Reset Threshold	V <sub>2</sub> , V <sub>3</sub> Input Threshold	●	2.300	2.338	2.375	V
			●	2.175	2.213	2.250	V
V <sub>RT18</sub>	1.8V, 5% Reset Threshold 1.8V, 10% Reset Threshold	V <sub>3</sub> , V <sub>4</sub> Input Threshold	●	1.656	1.683	1.710	V
			●	1.566	1.593	1.620	V
V <sub>RT15</sub>	1.5V, 5% Reset Threshold 1.5V, 10% Reset Threshold	V <sub>3</sub> , V <sub>4</sub> Input Threshold	●	1.380	1.403	1.425	V
			●	1.305	1.328	1.350	V
V <sub>RTA</sub>	ADJ, 5% Reset Threshold ADJ, 10% Reset Threshold	V <sub>3</sub> , V <sub>4</sub> Input Threshold	●	0.492	0.500	0.508	V
			●	0.466	0.473	0.481	V
V <sub>RTAN</sub>	-ADJ Reset Threshold	V <sub>4</sub> Input Threshold	●	-18	0	18	mV
V <sub>CC</sub>	Minimum Internal Operating Voltage	RST, COMPX in Correct Logic State; V <sub>CC</sub> Rising Prior to Program	●			1	V

2901fb

**ELECTRICAL CHARACTERISTICS**

The ● denotes the specifications which apply over the full operating temperature range, otherwise specifications are at  $T_A = 25^\circ\text{C}$ .  $V_{CC} = 5\text{V}$ , unless otherwise noted. (Notes 3, 4)

SYMBOL	PARAMETER	CONDITIONS	MIN	TYP	MAX	UNITS	
$V_{CCMINP}$	Minimum Required for Programming	$V_{CC}$ Rising	●		2.42	V	
$V_{CCMINC}$	Minimum Required for Comparators	$V_{CC}$ Falling	●		2.32	V	
$V_{REF}$	Reference Voltage	$V_{CC} \geq 2.3\text{V}$ , $I_{VREF} = \pm 1\text{mA}$ , $C_{REF} \leq 1000\text{pF}$	●	1.192	1.210	1.228	V
		TOL Low	●	1.128	1.146	1.163	V
$V_{PG}$	Programming Voltage Range	$V_{CC} \geq V_{CCMINP}$	●	0	$V_{REF}$	V	
$I_{VPG}$	$V_{PG}$ Input Current	$V_{PG} = V_{REF}$	●		$\pm 20$	nA	
$I_{V1}$	V1 Input Current	$V1 = 5\text{V}$ , $I_{VREF} = 12\mu\text{A}$ , (Note 5)	●	43	75	$\mu\text{A}$	
$I_{V2}$	V2 Input Current	$V2 = 3.3\text{V}$	●	0.8	2	$\mu\text{A}$	
$I_{V3}$	V3 Input Current	$V3 = 2.5\text{V}$	●		0.52	1.2	$\mu\text{A}$
		$V3 = 0.55\text{V}$ (ADJ Mode)	●	-15		15	nA
$I_{V4}$	V4 Input Current	$V4 = 1.8\text{V}$	●		0.34	0.8	$\mu\text{A}$
		$V4 = 0.55\text{V}$ (ADJ Mode)	●	-15		15	nA
		$V4 = -0.05\text{V}$ (-ADJ Mode)	●	-15		15	nA
$I_{CRT(UP)}$	CRT Pull-Up Current	$V_{CRT} = 0\text{V}$	●	-1.4	-2	-2.6	$\mu\text{A}$
$I_{CRT(DN)}$	CRT Pull-Down Current	$V_{CRT} = 1.3\text{V}$	●	10	20	30	$\mu\text{A}$
$t_{RST}$	Reset Time-Out Period	$C_{RT} = 1500\text{pF}$	●	5	7	9	ms
$t_{UV}$	$V_X$ Undervoltage Detect to $\overline{\text{RST}}$ or COMPX	$V_X$ Less Than Reset Threshold $V_{RTX}$ by More Than 1%			150		$\mu\text{s}$
$V_{OL}$	Output Voltage Low $\overline{\text{RST}}$ , COMPX	$I_{SINK} = 2.5\text{mA}$ ; $V1 = 3\text{V}$ , $V2 = 3\text{V}$ ; $V3, V4 = 0\text{V}$ ; $V_{PG} = 0\text{V}$	●		0.15	0.4	V
		$I_{SINK} = 100\mu\text{A}$ ; $V2 = 1\text{V}$ ; $V1, V3, V4 = 0\text{V}$	●		0.05	0.3	V
		$I_{SINK} = 100\mu\text{A}$ ; $V1 = 1\text{V}$ ; $V2, V3, V4 = 0\text{V}$	●		0.05	0.3	V
$V_{OH}$	Output Voltage High $\overline{\text{RST}}$ , $\overline{\text{WDO}}$ , COMPX (Note 6)	$I_{SOURCE} = 1\mu\text{A}$	●	$V2 - 1$			V
$V_{OL}$	Output Voltage Low $\overline{\text{WDO}}$	$I_{SINK} = 2.5\text{mA}$ ; $V1 = 5\text{V}$ , $V2 = 3.3\text{V}$ ; $V3, V4 = 1\text{V}$ ; $V_{PG} = 0\text{V}$	●		0.15	0.4	V
$V_{OH}$	Output Voltage High $\overline{\text{RST}}$ (LTC2901-2/LTC2901-4) (Note 7)	$I_{SOURCE} = 200\mu\text{A}$	●	$0.8 \cdot V2$			V
$I_{CWT(UP)}$	CWT Pull-Up Current	$V_{CWT} = 0\text{V}$	●	-1.4	-2	-2.6	$\mu\text{A}$
$I_{CWT(DN)}$	CWT Pull-Down Current	$V_{CWT} = 1.3\text{V}$	●	10	20	30	$\mu\text{A}$
$t_{WD}$	Watchdog Time-Out Period	$C_{WT} = 1500\text{pF}$	●	20	30	40	ms
$V_{IH}$	WDI Input Threshold High	$V_{CC} = 3.3\text{V}$ to $5.5\text{V}$	●			1.6	V
$V_{IL}$	WDI Input Threshold Low	$V_{CC} = 3.3\text{V}$ to $5.5\text{V}$	●	0.4			V
$t_{WP}$	WDI Input Pulse Width	$V_{CC} = 3.3\text{V}$	●	150			ns
$I_{WDI}$	WDI Pull-Up Current	$V_{WDI} = 0\text{V}$			-10		$\mu\text{A}$
<b>Digital Input TOL</b>							
$V_{IL}$	TOL Low Level Input Voltage	$V_{CC} = 3.3\text{V}$ to $5.5\text{V}$	●		$0.3V_{CC}$		V
$V_{IH}$	TOL High Level Input Voltage	$V_{CC} = 3.3\text{V}$ to $5.5\text{V}$	●	$0.7V_{CC}$			V
$I_{INTOL}$	TOL Input Current	$TOL = V_{CC}$	●		$\pm 0.1$	$\pm 1$	$\mu\text{A}$

**Note 1:** Stresses beyond those listed under Absolute Maximum Ratings may cause permanent damage to the device. Exposure to any Absolute Maximum Rating condition for extended periods may affect device reliability and lifetime.

**Note 2:** All currents into pins are positive, all voltages are referenced to GND unless otherwise noted.

**Note 3:** The greater of V1, V2 is the internal supply voltage ( $V_{CC}$ ).

**Note 4:** 10% thresholds apply to the LTC2901-3/LTC2901-4 only when the TOL pin is set to a logic high.

**Note 5:** Under static no-fault conditions, V1 will necessarily supply quiescent current. If at any time V2 is larger than V1, V2 must be capable of supplying the quiescent current, programming (transient) current and reference load current.

**Note 6:** The output pins  $\overline{\text{RST}}$ ,  $\overline{\text{WDO}}$  and COMPX have internal pull-ups to V2 of typically  $6\mu\text{A}$ . However, external pull-up resistors may be used when faster rise times are required or for  $V_{OH}$  voltages greater than V2.

**Note 7:** The push-pull  $\overline{\text{RST}}$  output pin on the LTC2901-2/LTC2901-4 is actively pulled up to V2.

## TEST CIRCUITS

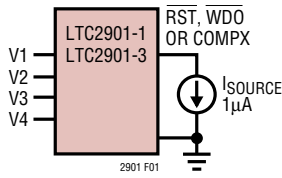

Figure 1.  $\overline{\text{RST}}$ ,  $\overline{\text{WDO}}$ ,  $\overline{\text{COMPX}}$   $V_{OH}$  Test

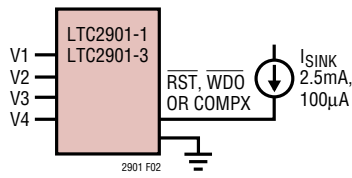

Figure 2.  $\overline{\text{RST}}$ ,  $\overline{\text{WDO}}$ ,  $\overline{\text{COMPX}}$   $V_{OL}$  Test

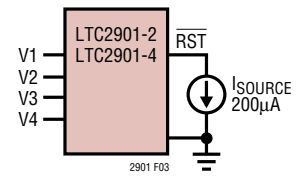
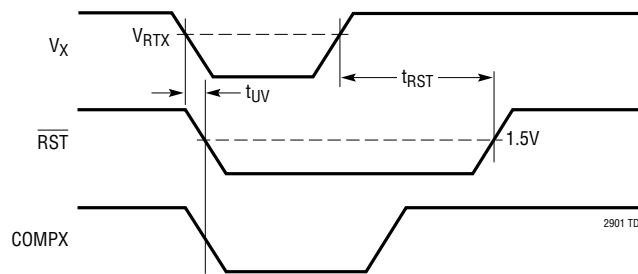

Figure 3. Active Pull-Up  $\overline{\text{RST}}$   $V_{OH}$  Test

## TIMING DIAGRAMS

### $V_X$ Monitor Timing



### Watchdog Timing (LTC2901-1/LTC2901-2)

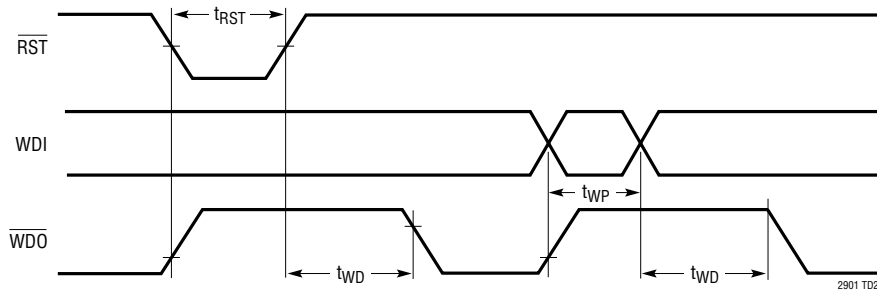

### Watchdog Timing (LTC2901-3/LTC2901-4)

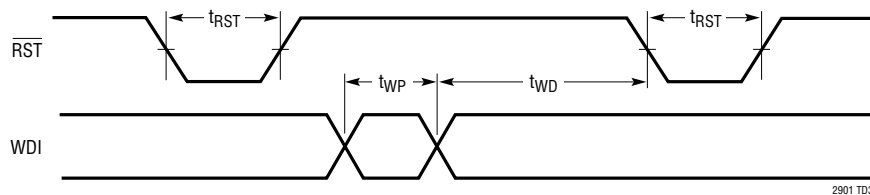

# TYPICAL PERFORMANCE CHARACTERISTICS

**5V Threshold Voltage vs Temperature**

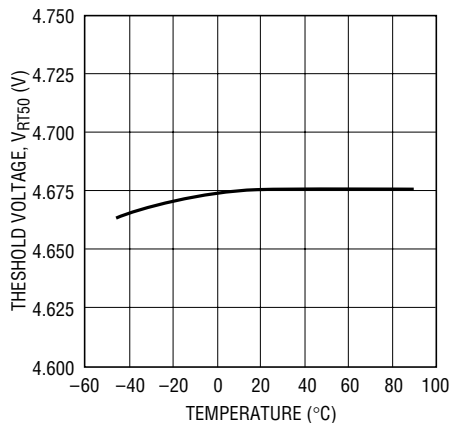

2901 G01

**3.3V Threshold Voltage vs Temperature**

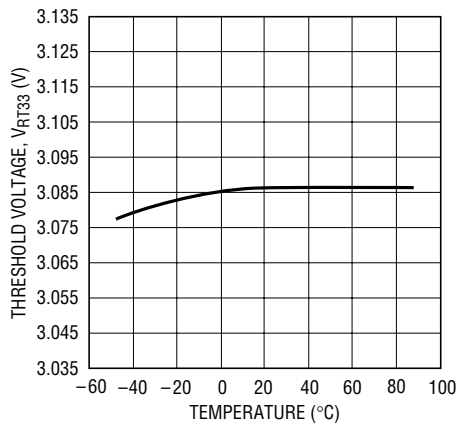

2901 G02

**3V Threshold Voltage vs Temperature**

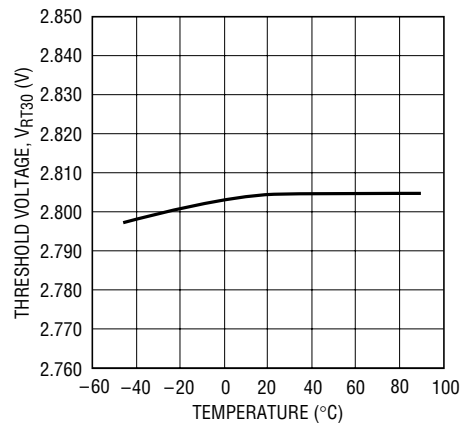

2901 G03

**2.5V Threshold Voltage vs Temperature**

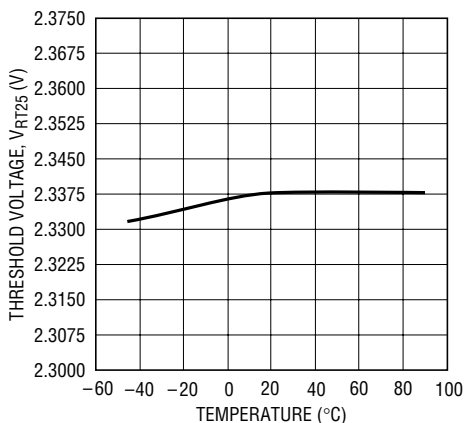

2901 G04

**1.8V Threshold Voltage vs Temperature**

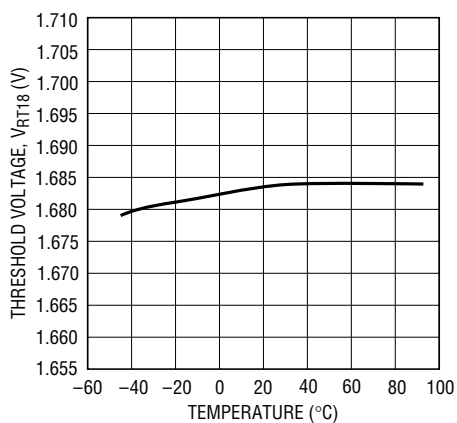

2901 G05

**1.5V Threshold Voltage vs Temperature**

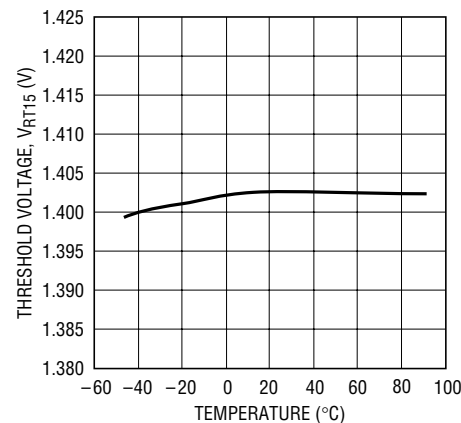

2901 G06

**ADJ Threshold Voltage vs Temperature**

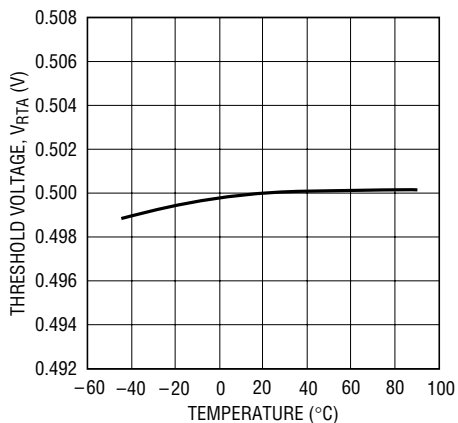

2901 G07

**-ADJ Threshold Voltage vs Temperature**

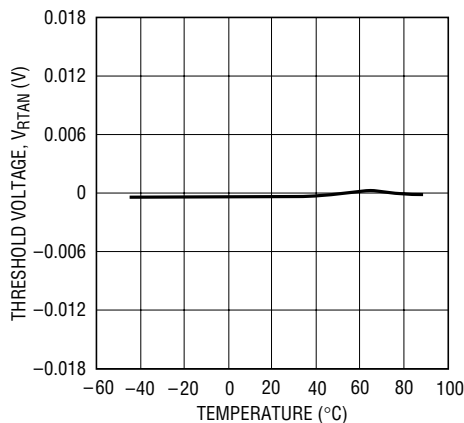

2901 G08

**V<sub>REF</sub> vs Temperature**

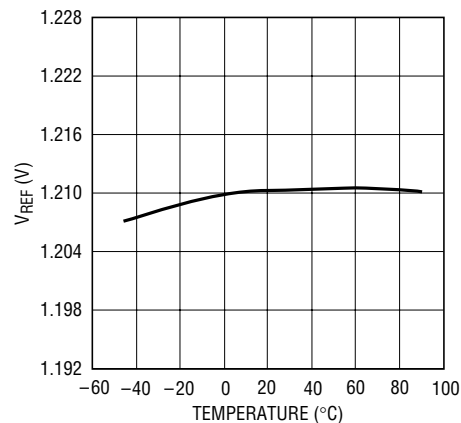

2901 G23

# TYPICAL PERFORMANCE CHARACTERISTICS

**$I_{V1}$  vs Temperature**

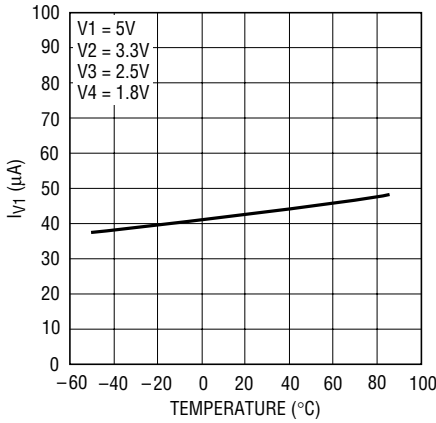

2901 G09

**$I_{V2}$  vs Temperature**

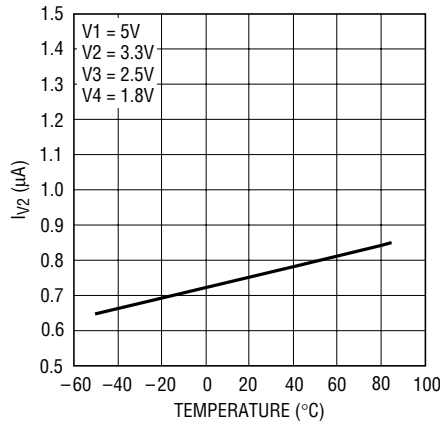

2901 G10

**$I_{V3}$  vs Temperature**

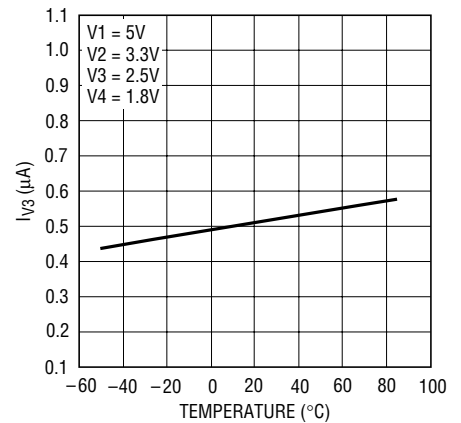

2901 G11

**$I_{V4}$  vs Temperature**

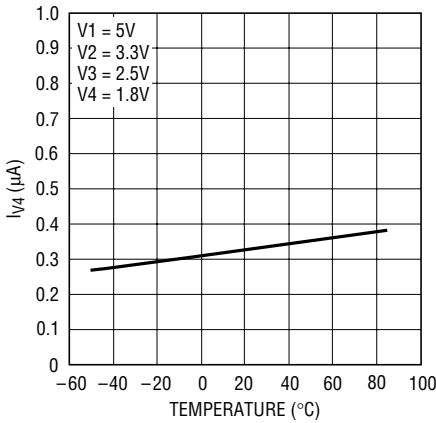

2901 G12

**Typical Transient Duration vs Comparator Overdrive ( $V1, V2$ )**

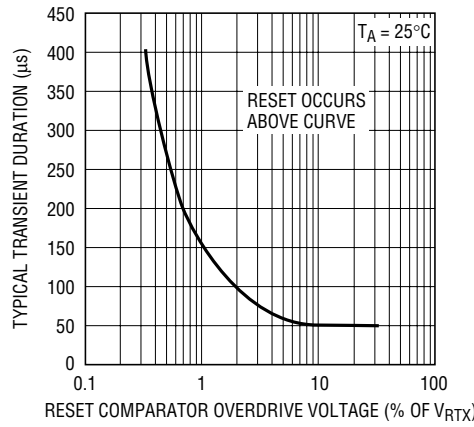

2901 G13

**Typical Transient Duration vs Comparator Overdrive ( $V3, V4$ )**

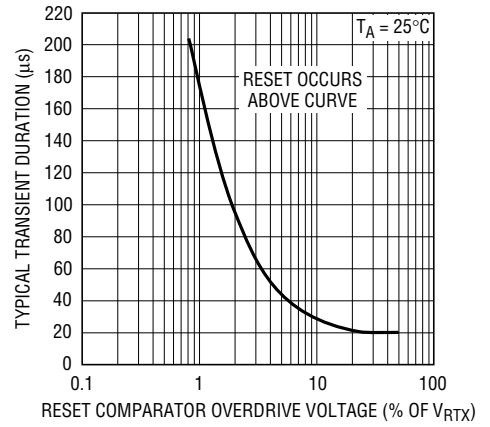

2901 G22

**$\overline{RST}$  Output Voltage vs  $V1, V_{PG} = 0V$**

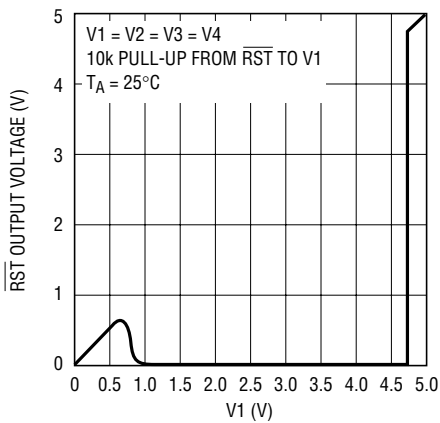

2901 G14

**Watchdog Time-Out Period vs Temperature**

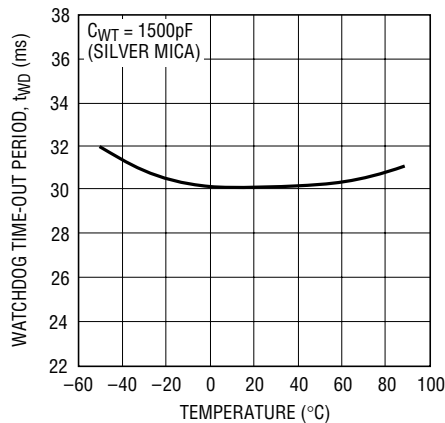

2901 G15

**Reset Time-Out Period vs Temperature**

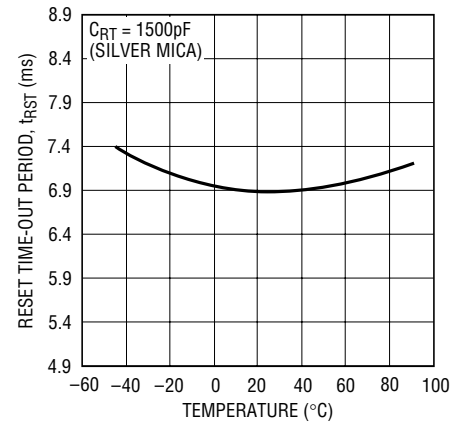

2901 G16

2901fb

# TYPICAL PERFORMANCE CHARACTERISTICS

**Watchdog Time-Out Period vs Capacitance**

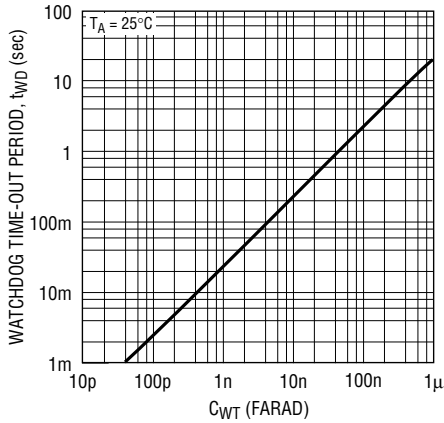

2901 G17

**Reset Time-Out Period vs Capacitance**

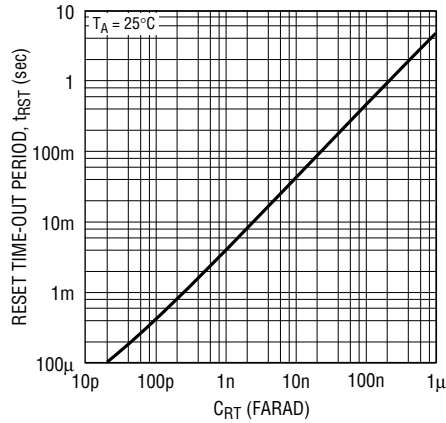

2901 G18

**RST, WDO, COMPX I<sub>SINK</sub> vs Supply Voltage**

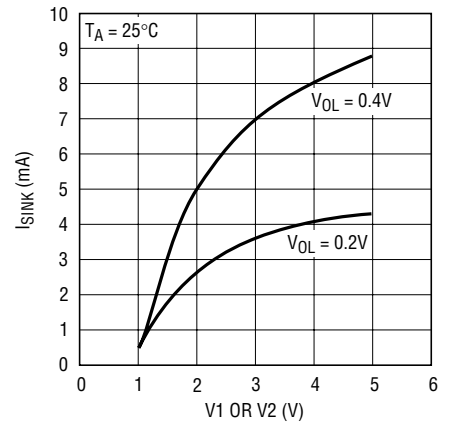

2901 G19

**RST, WDO, COMPX Voltage Output Low vs Output Sink Current**

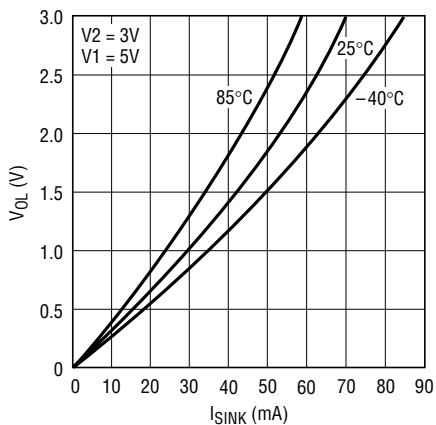

2901 G20

**RST High Level Output Voltage vs Output Source Current (LTC2901-2/LTC2901-4)**

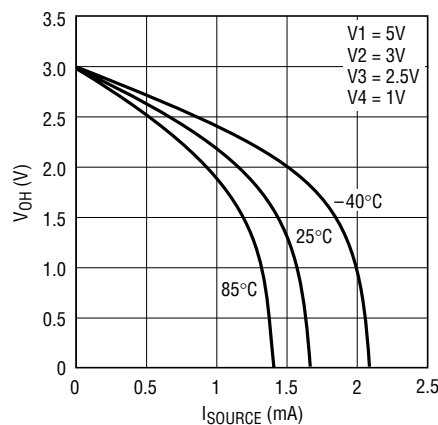

2901 G21

**COMPX and WDO Pull-Up Current vs V2 (COMPX and WDO Held at 0V)**

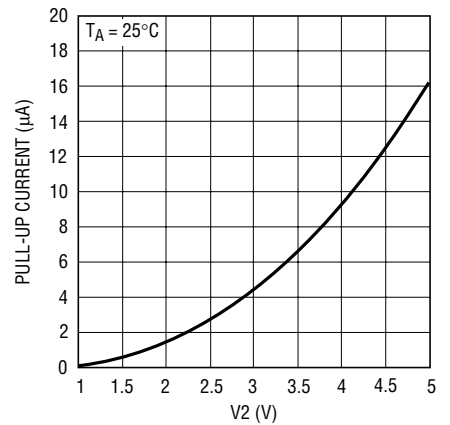

2901 G24

**COMPX Propagation Delay vs Input Overdrive Above Threshold**

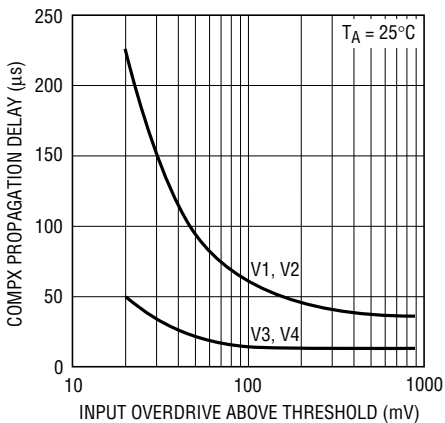

2901 G25

**RST Pull-Up Current vs V2 (LTC2901-1/LTC2901-3)**

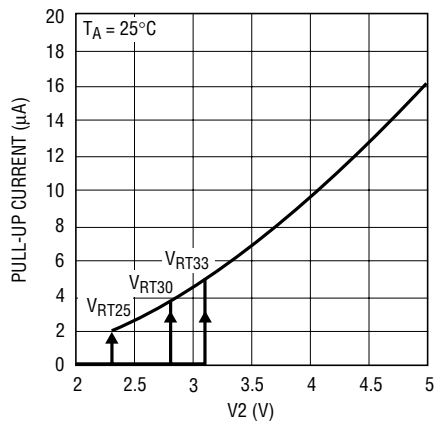

2901 G26

**RST Pull-Up Current vs V2 (LTC2901-2/LTC2901-4)**

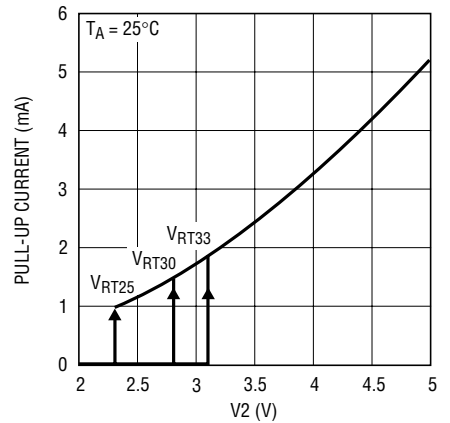

2901 G27  
2901fb

## PIN FUNCTIONS

**COMP3 (Pin 1):** Comparator Output 3. Nondelayed, active high logic output with weak pull-up to V2. Pulls high when V3 is above reset threshold. May be pulled greater than V2 using external pull-up.

**COMP1 (Pin 2):** Comparator Output 1. Nondelayed, active high logic output with weak pull-up to V2. Pulls high when V1 is above reset threshold. May be pulled greater than V2 using external pull-up.

**V3 (Pin 3):** Voltage Input 3. Select from 2.5V, 1.8V, 1.5V or ADJ. See Table 1 for details.

**V1 (Pin 4):** Voltage Input 1. Select from 5V or 3.3V. See Table 1 for details. The greater of (V1, V2) is also  $V_{CC}$  for the device. Bypass this pin to ground with a 0.1 $\mu$ F (or greater) capacitor.

**CRT (Pin 5):** Reset Delay Time Programming Pin. Attach an external capacitor ( $C_{RT}$ ) to GND to set a reset delay time of 4.6ms/nF. Leaving the pin open generates a minimum delay of approximately 50 $\mu$ s. A 47nF capacitor will generate a 216ms reset delay time.

**RST (Pin 6):** Reset Logic Output. Active low with weak pull-up to V2 (LTC2901-1/LTC2901-3) or active pull-up to V2 (LTC2901-2/LTC2901-4). Pulls low when any voltage input is below the reset threshold and held low for the programmed delay time after all voltage inputs are above threshold. May be pulled above V2 using an external pull-up (LTC2901-1/LTC2901-3 only).

**$\overline{WDO}$  (Pin 7):** LTC2901-1/LTC2901-2 Watchdog Output. Active low logic output with weak pull-up to V2. May be pulled greater than V2 using external pull-up. The watchdog output pulls low if the watchdog timer is allowed to time out and remains low until set high by the next WDI transition or anytime  $\overline{RST}$  is low. The watchdog timer is enabled when  $\overline{RST}$  is high.

**TOL (Pin 7):** LTC2901-3/LTC2901-4 Digital Input for Supply Tolerance Selection (5% or 10%). A logic low selects 5% thresholds; a logic high selects 10% thresholds.

**WDI (Pin 8):** Watchdog Input. A logic input whose rising or falling edge must occur on this pin (while  $\overline{RST}$  is high) within the selected watchdog time-out period, prohibiting a high-to-low transition on the  $\overline{WDO}$  pin (LTC2901-1/LTC2901-2). The watchdog time-out period is set by the value of the capacitor that is attached to the CWT pin.

A rising or falling edge on the WDI pin clears the voltage on the  $C_{WT}$  capacitor, preventing WDO from going low. When disabling the watchdog function, tie CWT to GND.

For the LTC2901-3/LTC2901-4, a watchdog time-out due to a missed WDI edge issues an  $\overline{RST}$  pulse on the  $\overline{RST}$  pin (the WDO function is merged into the  $\overline{RST}$  function).

**CWT (Pin 9):** Watchdog Time-Out Programming Pin. Attach a capacitor ( $C_{WT}$ ) between CWT and GND to set a watchdog time-out period of 20ms/nF. Leaving the pin open generates a minimum time-out of approximately 200 $\mu$ s. A 47nF capacitor will generate a 940ms watchdog time-out period.

**GND (Pin 10):** Ground.

**$V_{PG}$  (Pin 11):** Voltage Threshold Combination Select Input. Connect to an external 1% resistive divider between  $V_{REF}$  and GND to select 1 of 16 combinations of preset and/or  $\pm$ adjustable voltage thresholds (see Table 1). Do not add capacitance on the  $V_{PG}$  pin.

**$V_{REF}$  (Pin 12):** Buffered Reference Voltage. A 1.210V nominal reference used for programming voltage ( $V_{PG}$ ) and for the offset of negative adjustable applications. The buffered reference can source and sink up to 1mA. The reference can drive a bypass capacitor of up to 1000pF without oscillation.

**V4 (Pin 13):** Voltage Input 4. Select from 1.8V, 1.5V, ADJ or  $-\text{ADJ}$ . See Table 1 for details.

**V2 (Pin 14):** Voltage Input 2. Select from 3.3V, 3V or 2.5V. See Table 1 for details. The greater of (V1, V2) is also  $V_{CC}$  for device. Bypass this pin to ground with a 0.1 $\mu$ F (or greater) capacitor. All logic outputs (COMP1, COMP2, COMP3, COMP4,  $\overline{RST}$ ,  $\overline{WDO}$ ) are weakly pulled up to V2 (LTC2901-1/LTC2901-3).  $\overline{RST}$  is actively pulled up to V2 in the LTC2901-2/LTC2901-4.

**COMP4 (Pin 15):** Comparator Output 4. Nondelayed, active high logic output with weak pull-up to V2. Pulls high when V4 is above reset threshold. May be pulled greater than V2 using external pull-up.

**COMP2 (Pin 16):** Comparator Output 2. Nondelayed, active high logic output with weak pull-up to V2. Pulls high when V2 is above reset threshold. May be pulled greater than V2 using external pull-up.



# BLOCK DIAGRAM

LTC2901-1/LTC2901-2

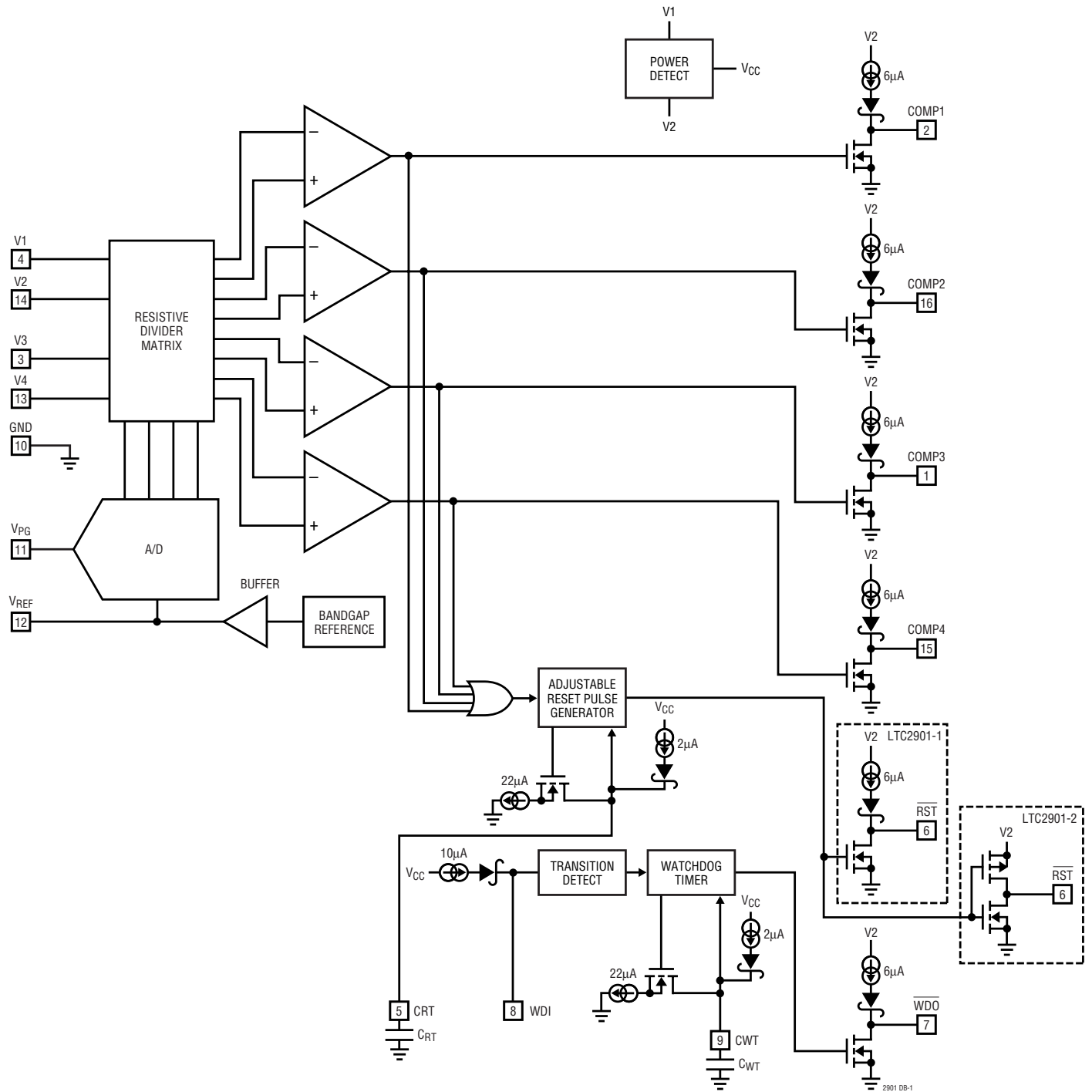

**BLOCK DIAGRAM**

LTC2901-3/LTC2901-4

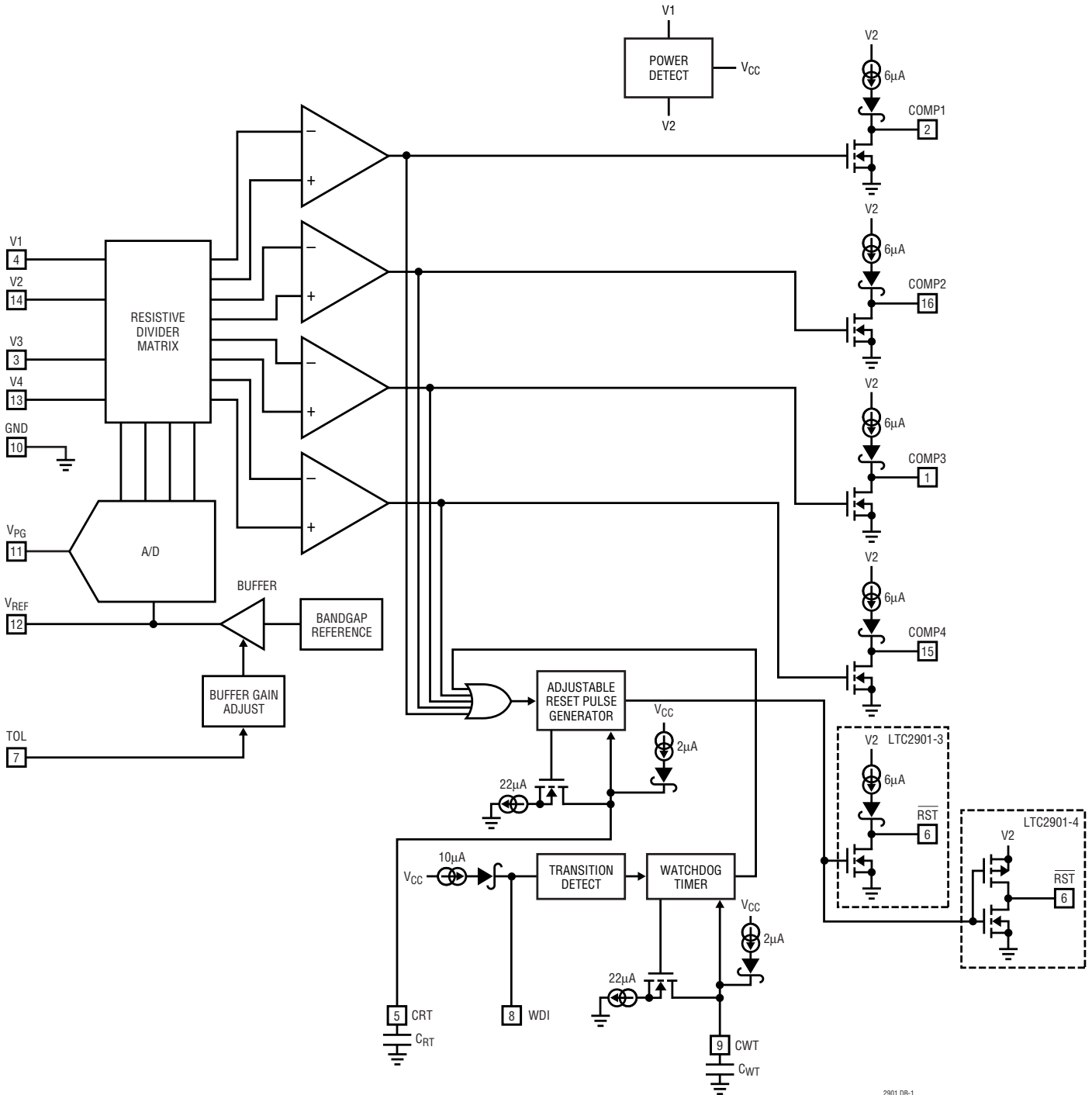

2901 DB-1

## APPLICATIONS INFORMATION

### Power-Up

The greater of V1, V2 is the internal supply voltage ( $V_{CC}$ ). On power-up,  $V_{CC}$  will power the drive circuits for the  $\overline{RST}$  and the COMPX pins. This ensures that the  $\overline{RST}$  and COMPX outputs will be low as soon as V1 or V2 reaches 1V. The  $\overline{RST}$  and COMPX outputs will remain low until the part is programmed. After programming, if any one of the  $V_X$  inputs is below its programmed threshold,  $\overline{RST}$  will be a logic low. Once all the  $V_X$  inputs rise above their thresholds, an internal timer is started and  $\overline{RST}$  is released after the programmed delay time. If  $V_{CC} < (V3 - 1)$  and  $V_{CC} < 2.4V$ , the V3 input impedance will be low ( $1k\Omega$  typ).

### Monitor Programming

The LTC2901 input voltage combination is selected by placing the recommended resistive divider from  $V_{REF}$  to GND and connecting the tap point to  $V_{PG}$ , as shown in Figure 4. Table 1 offers recommended 1% resistor values for the various modes. The last column in Table 1 specifies optimum  $V_{PG}/V_{REF}$  ratios ( $\pm 0.01$ ) to be used when programming with a ratiometric DAC.

During power-up, once V1 or V2 reaches 2.4V max, the monitor enters a programming period of approximately

**Table 1. Voltage Threshold Programming**

MODE	V1 (V)	V2 (V)	V3 (V)	V4 (V)	R1 (k $\Omega$ )	R2 (k $\Omega$ )	$\frac{V_{PG}}{V_{REF}}$
0	5.0	3.3	ADJ	ADJ	Open	Short	0.000
1	5.0	3.3	ADJ	-ADJ	93.1	9.53	0.094
2	3.3	2.5	ADJ	ADJ	86.6	16.2	0.156
3	3.3	2.5	ADJ	-ADJ	78.7	22.1	0.219
4	3.3	2.5	1.5	ADJ	71.5	28.0	0.281
5	5.0	3.3	2.5	ADJ	66.5	34.8	0.344
6	5.0	3.3	2.5	1.8	59.0	40.2	0.406
7	5.0	3.3	2.5	1.5	53.6	47.5	0.469
8	5.0	3.0	2.5	ADJ	47.5	53.6	0.531
9	5.0	3.0	ADJ	ADJ	40.2	59.0	0.594
10	3.3	2.5	1.8	1.5	34.8	66.5	0.656
11	3.3	2.5	1.8	ADJ	28.0	71.5	0.719
12	3.3	2.5	1.8	-ADJ	22.1	78.7	0.781
13	5.0	3.3	1.8	-ADJ	16.2	86.6	0.844
14	5.0	3.3	1.8	ADJ	9.53	93.1	0.906
15	5.0	3.0	1.8	ADJ	Short	Open	1.000

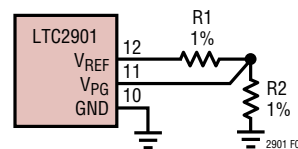

**Figure 4. Monitor Programming**

150 $\mu$ s during which the voltage on the  $V_{PG}$  pin is sampled and the monitor is configured to the desired input combination. Do not add capacitance to the  $V_{PG}$  pin. Immediately after programming, the comparators are enabled and supply monitoring will begin.

### Supply Monitoring

The LTC2901 is a low power, high accuracy programmable quad supply monitoring circuit with four nondelayed monitor outputs, a common reset output and a watchdog timer. Watchdog and reset timing are both adjustable using external capacitors. Single pin programming selects 1 of 16 input voltage monitor combinations. All four voltage inputs must be above predetermined thresholds for the reset not to be invoked. The LTC2901 will assert the reset and comparator outputs during power-up, power-down and brownout conditions on any one of the voltage inputs.

The inverting inputs on the V3 and/or V4 comparators are set to 0.5V when the positive adjustable modes are selected (Figure 5). The tap point on an external resistive divider, connected between the positive voltage being sensed and ground, is connected to the high impedance noninverting inputs (V3, V4). The trip voltage is calculated from:

$$V_{TRIP} = 0.5V \left( 1 + \frac{R3}{R4} \right)$$

In the negative adjustable mode, the noninverting input on the V4 comparator is connected to ground (Figure 6). The tap point on an external resistive divider, connected between the negative voltage being sensed and the  $V_{REF}$  pin, is connected to the high impedance inverting input (V4).  $V_{REF}$  provides the necessary level shift required to operate at ground. The trip voltage is calculated from:

$$V_{TRIP} = -V_{REF} \left( \frac{R3}{R4} \right); V_{REF} = 1.210V \text{ Nominal}$$

## APPLICATIONS INFORMATION

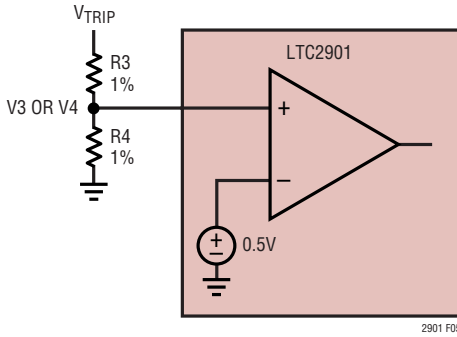

Figure 5. Setting the Positive Adjustable Trip Point

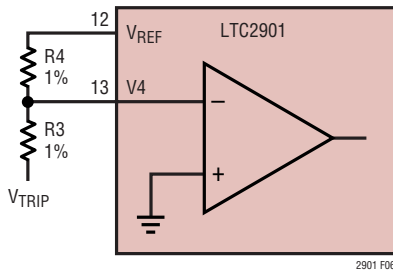

Figure 6. Setting the Negative Adjustable Trip Point

In a negative adjustable application, the minimum value for R4 is limited by the sourcing capability of V<sub>REF</sub> (±1mA). With no other load on V<sub>REF</sub>, R4 (minimum) is:

$$1.21\text{V} \div 1\text{mA} = 1.21\text{k}\Omega.$$

Tables 2 and 3 offer suggested 1% resistor values for various adjustable applications.

Once the resistor divider is set in the 5% tolerance mode (LTC2901-3/LTC2901-4), there is no need to change the divider for the 10% mode because the internal and external reference is scaled accordingly, moving the trip point by -5%.

Although all four supply monitor comparators have built-in glitch immunity, bypass capacitors on V1 and V2 are recommended because the greater of V1 or V2 is also the V<sub>CC</sub> for the device. Filter capacitors on the V3 and V4 inputs are allowed.

### Power-Down

On power-down, once any of the V<sub>X</sub> inputs drop below their threshold, RST and COMPX are held at a logic low. A logic low of 0.4V is guaranteed until both V1 and V2 drop below 1V. If the bandgap reference becomes invalid

Table 2. Suggested 1% Resistor Values for the ADJ Inputs

V <sub>SUPPLY</sub> (V)	V <sub>TRIP</sub> (V)	R3 (kΩ)	R4 (kΩ)
12	11.25	2150	100
10	9.4	1780	100
8	7.5	1400	100
7.5	7	1300	100
6	5.6	1020	100
5	4.725	845	100
3.3	3.055	511	100
3	2.82	464	100
2.5	2.325	365	100
1.8	1.685	237	100
1.5	1.410	182	100
1.2	1.120	124	100
1	0.933	86.6	100
0.9	0.840	68.1	100

Table 3. Suggested 1% Resistor Values for the -ADJ Input

V <sub>SUPPLY</sub> (V)	V <sub>TRIP</sub> (V)	R3 (kΩ)	R4 (kΩ)
-2	-1.87	187	121
-5	-4.64	464	121
-5.2	-4.87	487	121
-10	-9.31	931	121
-12	-11.30	1130	121

(V<sub>CC</sub> < 2V typ), the part will reprogram once V<sub>CC</sub> rises above 2.4V max.

### Monitor Output Rise and Fall Time Estimation

All of the outputs ( $\overline{\text{RST}}$ , COMPX,  $\overline{\text{WDO}}$ ) have strong pull-down capability. If the external load capacitance (C<sub>LOAD</sub>) for a particular output is known, output fall time (10% to 90%) is estimated using:

$$t_{\text{FALL}} \approx 2.2 \cdot R_{\text{PD}} \cdot C_{\text{LOAD}}$$

where R<sub>PD</sub> is the on-resistance of the internal pull-down transistor. The typical performance curve (V<sub>OL</sub> vs I<sub>SINK</sub>) demonstrates that the pull-down current is somewhat linear versus output voltage. Using the 25°C curve, R<sub>PD</sub> is estimated to be approximately 40Ω. Assuming a 150pF load capacitance, the fall time is about 13.2ns.

Although the outputs are considered to be “open-drain,” they do have a weak pull-up capability (see COMPX or  $\overline{\text{RST}}$

## APPLICATIONS INFORMATION

Pull-Up Current vs V2 curve). Output rise time (10% to 90%) is estimated using:

$$t_{RISE} \approx 2.2 \cdot R_{PU} \cdot C_{LOAD}$$

where  $R_{PU}$  is the on-resistance of the pull-up transistor. The on-resistance as a function of the V2 voltage at room temperature is estimated using:

$$R_{PU} = \frac{6 \cdot 10^5}{V2 - 1} \Omega$$

with  $V2 = 3.3V$ ,  $R_{PU}$  is about 260k. Using 150pF for load capacitance, the rise time is 86 $\mu$ s. If the output needs to pull up faster and/or to a higher voltage, a smaller external pull-up resistor may be used. Using a 10k pull-up resistor, the rise time is reduced to 3.3 $\mu$ s for a 150pF load capacitance.

The LTC2901-2 has an active pull-up to V2 on the  $\overline{RST}$  output. The typical performance curve ( $\overline{RST}$  Pull-Up Current vs V2 curve) demonstrates that the pull-up current is somewhat linear versus the V2 voltage and  $R_{PU}$  is estimated to be approximately 625 $\Omega$ . A 150pF load capacitance makes the rise time about 206ns.

### Watchdog Timer

The watchdog circuit typically monitors a  $\mu$ P's activity. The  $\mu$ P is required to change the logic state of the WDI pin on a periodic basis in order to clear the watchdog timer and prevent the  $\overline{WDO}$  pin (LTC2901-1/LTC2901-2) from going low. Whenever  $\overline{RST}$  is low, the watchdog timer is cleared and  $\overline{WDO}$  is set high. The watchdog timer is started when  $\overline{RST}$  pulls high. Subsequent edges received on the WDI pin will clear the watchdog timer. The timer will continue to run until the watchdog timer times out. Once the watchdog timer times out, internal circuitry will bring the  $\overline{WDO}$  pin low.  $\overline{WDO}$  will remain low and the watchdog timer will remain cleared until the next edge is received on the WDI pin or until  $\overline{RST}$  goes low.

In the LTC2901-3/LTC2901-4, there is no  $\overline{WDO}$  pin. Instead, the  $\overline{RST}$  pin is pulled low for the programmed reset time-out period whenever a WDI edge is missed. In this manner, a full system reset can be issued after a watchdog failure.

To disable the watchdog timer, simply ground the CWT pin (Pin 9). With CWT held at ground, any reset event will force

$\overline{WDO}$  high indefinitely. It is safe to leave the WDI pin (Pin 8) unconnected because the weak internal pull-up (10 $\mu$ A typ) will pull WDI high. Tying WDI to V1 or ground is also allowed, but grounding the WDI pin will force the pull-up current to be drawn continuously.

### Selecting the Reset Timing Capacitor

The reset time-out period is adjustable in order to accommodate a variety of microprocessor applications. The reset time-out period,  $t_{RST}$ , is adjusted by connecting a capacitor,  $C_{RT}$ , between the CRT pin and ground. The value of this capacitor is determined by:

$$C_{RT} = t_{RST} \cdot 217 \cdot 10^{-9}$$

with  $C_{RT}$  in Farads and  $t_{RST}$  in seconds. The  $C_{RT}$  value per millisecond of delay can also be expressed as  $C_{RT}/ms = 217$  (pF/ms).

Leaving the CRT pin unconnected will generate a minimum reset time-out of approximately 50 $\mu$ s. Maximum reset time-out is limited by the largest available low leakage capacitor. The accuracy of the time-out period will be affected by capacitor leakage (the nominal charging current is 2 $\mu$ A) and capacitor tolerance. A low leakage ceramic capacitor is recommended.

### Selecting the Watchdog Timing Capacitor

The watchdog time-out period is adjustable and can be optimized for software execution. The watchdog time-out period,  $t_{WD}$ , is adjusted by connecting a capacitor,  $C_{WT}$ , between the CWT pin and ground. Given a specified watchdog time-out period, the capacitor is determined by:

$$C_{WT} = t_{WD} \cdot 50 \cdot 10^{-9}$$

with  $C_{WT}$  in Farads and  $t_{WD}$  in seconds. The  $C_{WT}$  value per millisecond of delay can also be expressed as  $C_{WT}/ms = 50$  (pF/ms).

Leaving the CWT pin unconnected will generate a minimum watchdog time-out of approximately 200 $\mu$ s. Maximum time-out is limited by the largest available low leakage capacitor. The accuracy of the time-out period will be affected by capacitor leakage (the nominal charging current is 2 $\mu$ A) and capacitor tolerance. A low leakage ceramic capacitor is recommended.

## APPLICATIONS INFORMATION

### Monitoring Power Supply Controller Activity

Figure 7 demonstrates how the LTC2901 can be used to monitor switcher activity. The monitor is configured to supervise 3.3V, 2.5V, 1.8V and one adjustable input. Because 2.5V does not exist in this application, the V2 input is tied to the V1 (3.3V) input. The feedback voltage on the LTC1772 (0.8V typ) is monitored with the adjustable input (V4). The RST pin will go high 216ms ( $C_{RT} = 47nF$ ) after the 3.3V and 1.8V supplies and the feedback voltage are above threshold. Individual input status is available at the COMPX pins.

While the voltage monitors can detect low voltage or shorted inputs, the watchdog circuit can be used to detect an open circuit to the primary load. With the CWT pin unconnected, the watchdog time-out is approximately 200 $\mu$ s. At low load currents on the 1.8V supply, the LTC1772 will go into Burst Mode<sup>®</sup> operation. With an open-circuit load, the duty cycle at the gate of M1 will drop, and the pulse spacing will exceed the watchdog time-out

period. The  $\overline{WDO}$  pin will go low indicating the low load condition. The  $\overline{WDO}$  pin will return high on the next pulse to the gate of M1. The  $\overline{WDO}$  pin will remain high if the load is restored.

### Ensuring Reset Valid for $V_{CC}$ Down to 0V (LTC2901-2/LTC2901-4)

Some applications require the reset output ( $\overline{RST}$ ) to be valid with  $V_{CC}$  down to 0V. The LTC2901-2 is designed to handle this requirement with the addition of an external resistor from RST to ground. The resistor will provide a path for stray charge and/or leakage currents, preventing the  $\overline{RST}$  output from floating to undetermined voltages when connected to high impedance (such as CMOS logic inputs). The resistor value should be small enough to provide effective pull-down without excessively loading the active pull-up circuitry. Too large a value may not pull down well enough. A 100k resistor from  $\overline{RST}$  to ground is satisfactory for most applications.

Burst Mode is a registered trademark of Linear Technology Corporation.

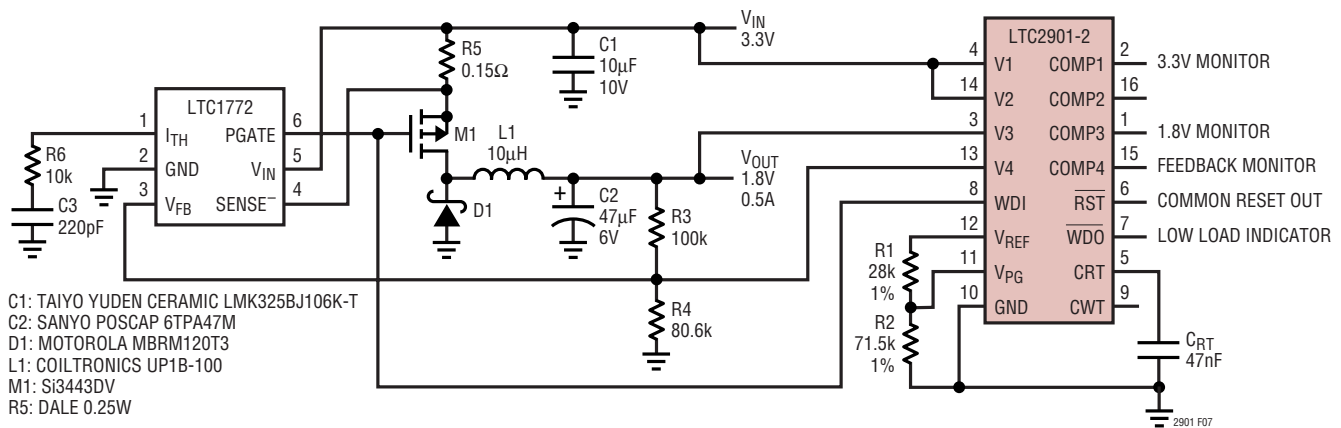
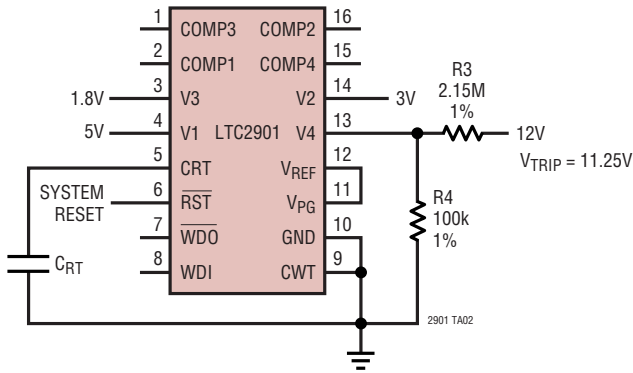

Figure 7. Monitor Input, Output, Feedback Voltage and Low Load Conditions on DC/DC Controller

# TYPICAL APPLICATIONS

**Quad Supply Monitor with Watchdog Timer Disabled  
5V, 3V, 1.8V, 12V (ADJ)**



**5V, -5V Monitor with Watchdog Timer Disabled and Unused  
V2, V3 Inputs Pulled Above Trip Thresholds**

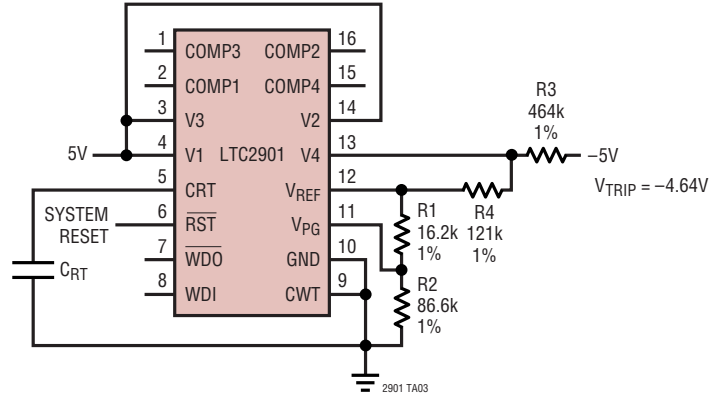

**Quad Supply Monitor with LED Undervoltage Indicators  
5V, 3.3V, 2.5V, 1.5V**

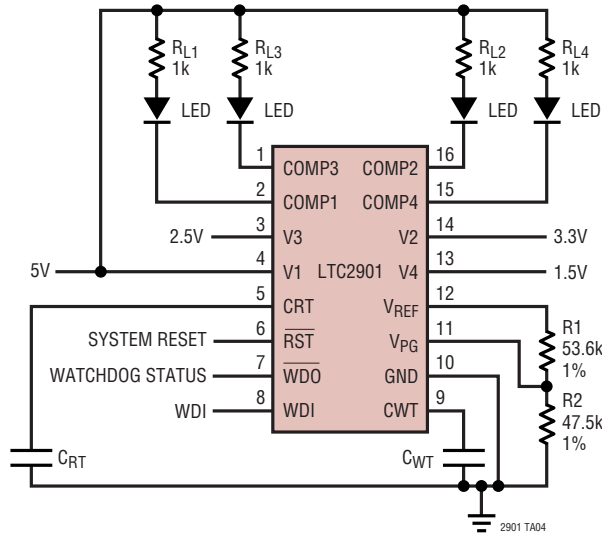

**Generate RESET Pulse Through Watchdog Timeout (LTC2901-1/LTC2901-2)**

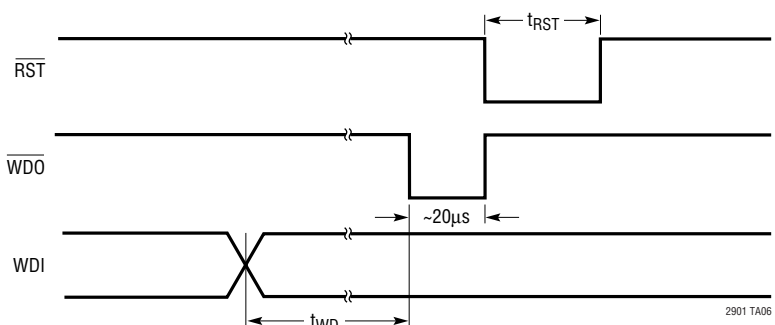
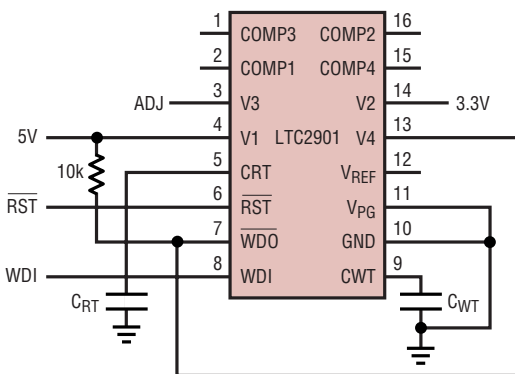

## TYPICAL APPLICATION

Monitor Seven Supplies (12V, 5V, 3.3V, 2.5V, 1.8V, -2V, -5.2V) with Sequenced Reset and AC Present Indication

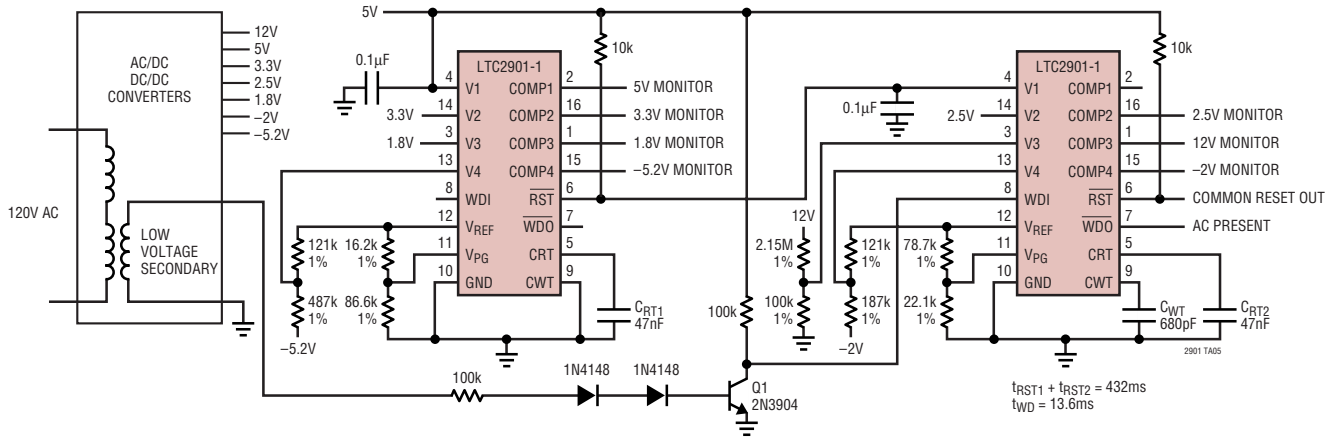

## PACKAGE DESCRIPTION

GN Package  
16-Lead Plastic SSOP (Narrow .150 Inch)  
(Reference LTC DWG # 05-08-1641)

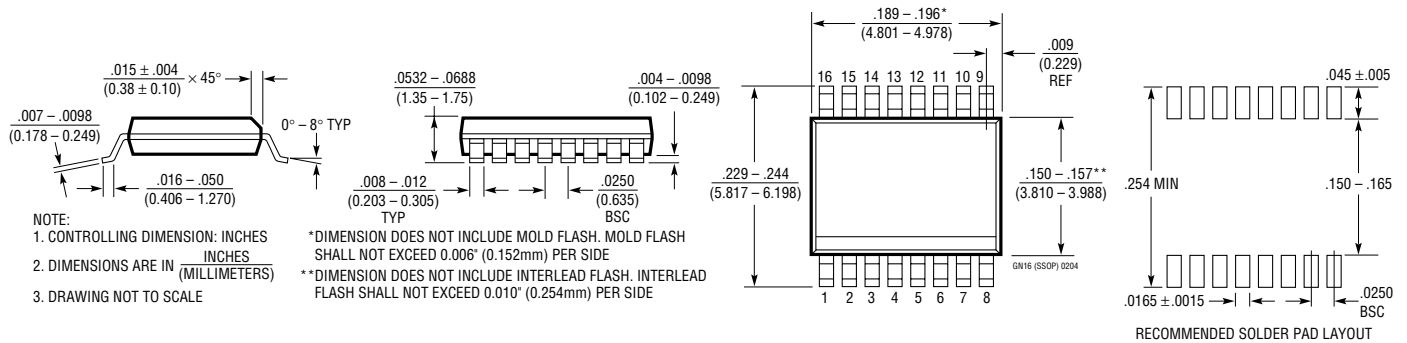

## RELATED PARTS

PART NUMBER	DESCRIPTION	COMMENTS
LTC694-3.3	3.3V Supply Monitor, Watchdog Timer and Battery Backup	2.9V Threshold
LTC1326	Micropower Precision Triple Supply Monitor for 5V, 3.3V and ADJ	4.725V, 3.118V, 1V Thresholds ( $\pm 0.75\%$ )
LTC1726-2.5	Micropower Triple Supply Monitor for 2.5V, 3.3V and ADJ	Adjustable $\overline{\text{RESET}}$ and Watchdog Time-Outs
LTC1727-2.5/LTC1727-5	Micropower Triple Supply Monitors with Open-Drain Reset	Individual Monitor Outputs in MSOP
LTC1728-1.8/LTC1728-3.3	Micropower Triple Supply Monitor with Open-Drain Reset	5-Lead SOT-23 Package
LTC2900	Programmable Quad Supply Monitor	Adjustable Reset Timer, 10-Lead MSOP and 3mm × 3mm 10-Lead DFN
LTC2902	Programmable Quad Supply Monitor	Adjustable Reset Timer, Supply Tolerance and Margining Functions, 16-Lead Narrow SSOP
LTC2903	Precision Quad Supply Monitor in 6-Lead SOT-23	A Variety of Factory Trimmed Voltage Combinations
LTC2904/LTC2905 LTC2906/LTC2907	Precision Dual Supply Monitors	Pin Selectable Thresholds
LTC2908	Precision Six Supply Monitor	8-Lead SOT-23 and DFN Packages

2901fb