

MULTIBLOCK 30 GD

Article Nr. 21.2220/0

[See the product on the website](#) →

[Download CAD Files](#) →

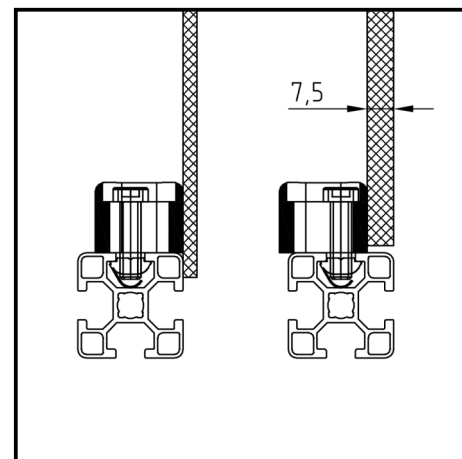
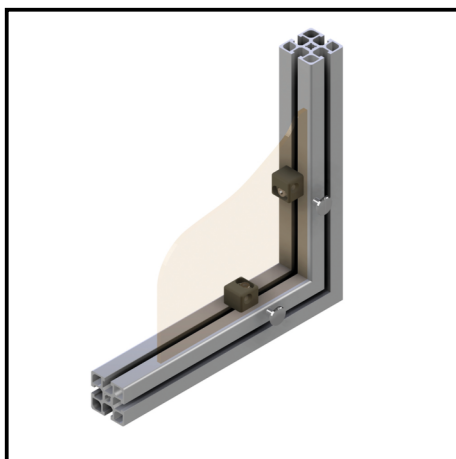
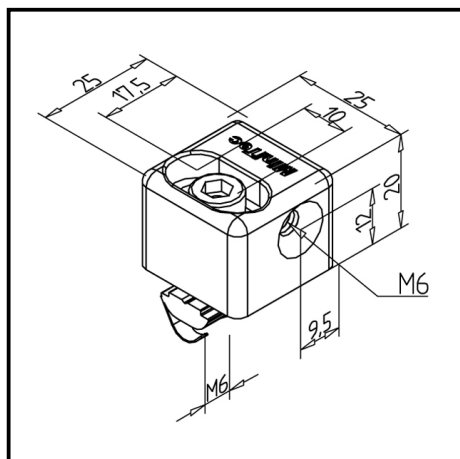

TECHN. DATA / ITEMS SUPPLIED

- Aluminium, Pressure die-casting, powder-coated, grey
- With fastening material steel, zinc plated
- Without pan head screw
- Weight = 0.032 kg/piece

APPLICATIONS

- Retrofitting surface elements and attachments
- Plate thickness of 6 to 7 mm can be continuously flush fit
- Alternatively, surface elements can also be mounted on-the-floor, so they can also be installed without an air gap.

ASSEMBLY

- Fastening surface elements or components with screw M6 or flat head screw
- Determination of panel dimensions: Light opening -4mm (~2 mm circulating air)
- Bore for fixation screws \varnothing 6.5 mm, edge distance 10 mm