

METRIC
 DIMENSIONS LISTED IN mm [INCHES]

AMP WIRE RANGE	E13288 Listed
12-10 AWG SOLID OR STRANDED	NOT APPLICABLE
LR7189 Certified	MILITARY P/N AND CLASS
NOT APPLICABLE	NOT APPLICABLE

STAMP AMP 12-10* APPROX AS SHOWN

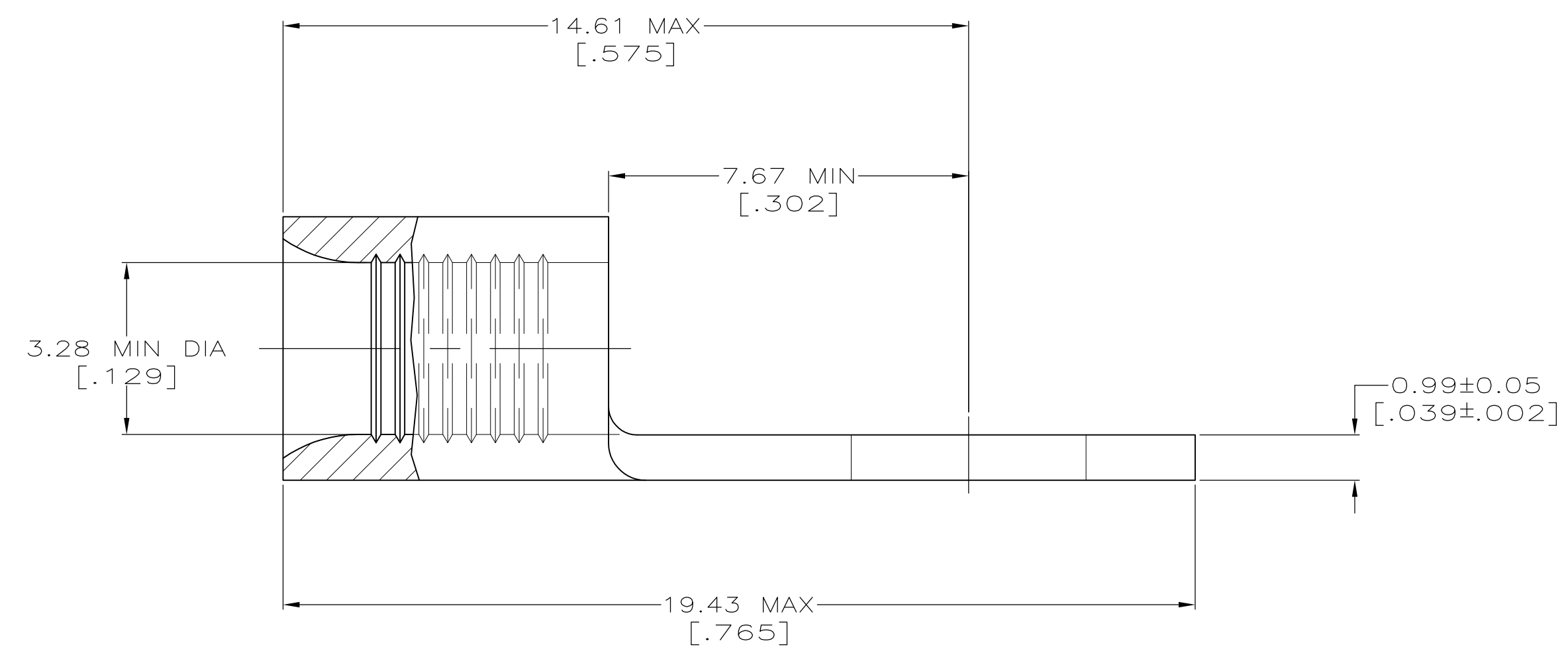
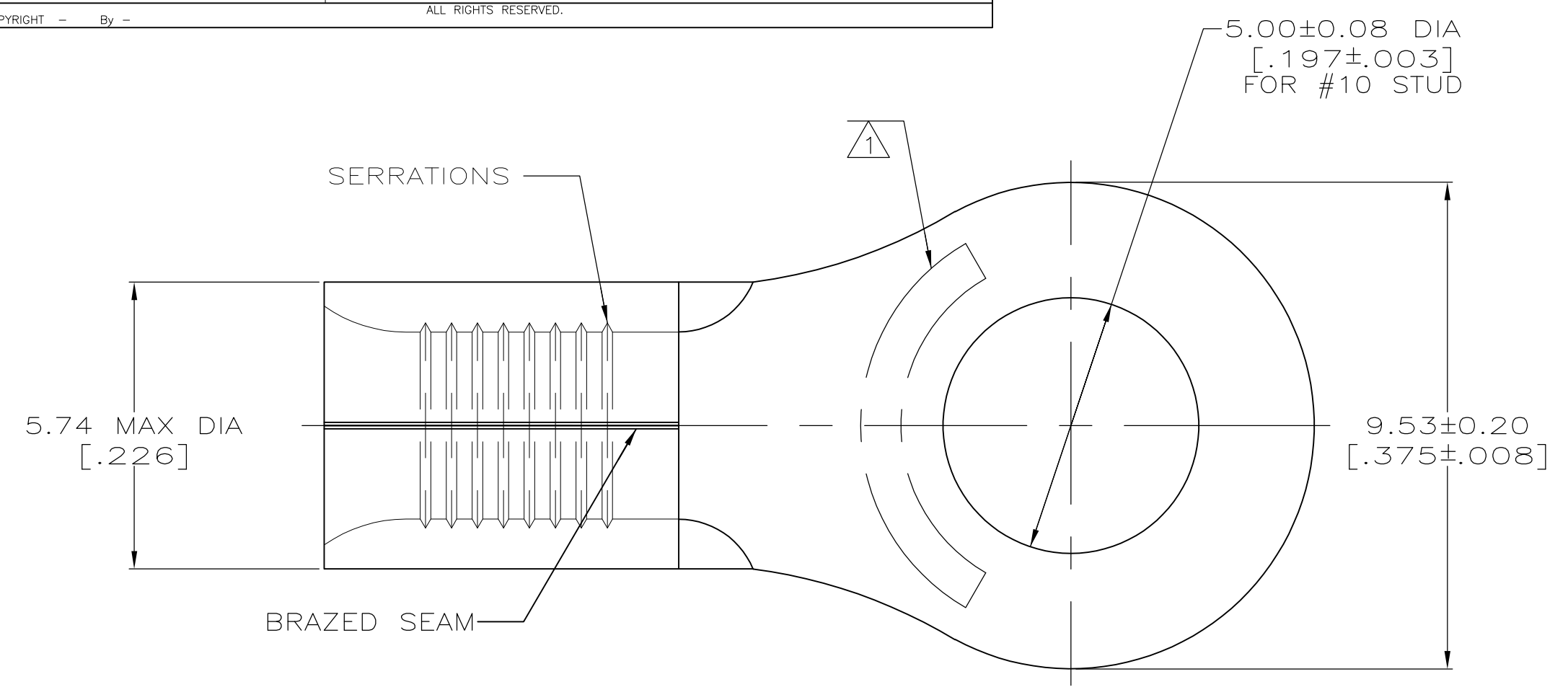

AMP INCORPORATED CUSTOMER SERVICE SYSTEMS		MAX RECOMMENDED OPERATING TEMPERATURE: 343° C MAX
FOR ADDITIONAL PRODUCT INFORMATION OR COPIES OF DRAWINGS AND TECHNICAL DOCUMENTS	PRODUCT INFORMATION CENTER 1-800-522-6752	VOLTAGE RATING: NOT APPLICABLE
FOR APPLICATION TOOLING INFORMATION	TOOLING ASSISTANCE CENTER 1-800-722-1111	WIRE CROSS SECTIONAL AREA RANGE: 2.62-6.64mm ² [5,180-13,100] CIR MILS SOLID OR STRANDED
FOR ORDER ENTRY	1-800-526-5142	THIS DRAWING IS A CONTROLLED DOCUMENT FOR AMP INCORPORATED. IT IS SUBJECT TO CHANGE AND THE CONTROLLING ENGINEERING ORGANIZATION SHOULD BE CONTACTED FOR THE LATEST REVISION.

2500	ON TAPE	2-323062-2
----	LOOSE PIECE	323062
QUANTITY	PACKAGING TYPE	PART NO

THIS DRAWING IS A CONTROLLED DOCUMENT.		DWN TA BRINKMAN 4-19-93	TE Connectivity											
DIMENSIONS: mm[INCHES]		CHK DA PATTERSON 4-19-93												
TOLERANCES UNLESS OTHERWISE SPECIFIED:		APVD DE MILLER 4-19-93												
<table border="1"> <tr><td>0 PLC</td><td>± -</td></tr> <tr><td>1 PLC</td><td>± -</td></tr> <tr><td>2 PLC</td><td>± -</td></tr> <tr><td>3 PLC</td><td>± -</td></tr> <tr><td>4 PLC</td><td>± -</td></tr> <tr><td>ANGLES</td><td>± ± -</td></tr> </table>		0 PLC		± -	1 PLC	± -	2 PLC	± -	3 PLC	± -	4 PLC	± -	ANGLES	± ± -
0 PLC	± -													
1 PLC	± -													
2 PLC	± -													
3 PLC	± -													
4 PLC	± -													
ANGLES	± ± -													
MATERIAL COPPER PER ASTM B-152 ANNEALED	FINISH NICKEL PLATE 0.00762[.000300] MIN THK PER QQ-N-290	WEIGHT -	SIZE A2											
CUSTOMER DRAWING		CAGE CODE 00779	DRAWING NO 323062											
		RESTRICTED TO -	SCALE 10:1 SHEET 1 OF 1 REV C1											