

Länge/Length (mm)	Toleranz/tolerance (mm)
< 300	± 15
300 - 1500	± 25
1500 - 3000	± 50
3000 - 7500	± 75
7500 - 10000	± 100
> 10000	explizit am Maß explicit on dimension

Cable assembly Plug - Socket

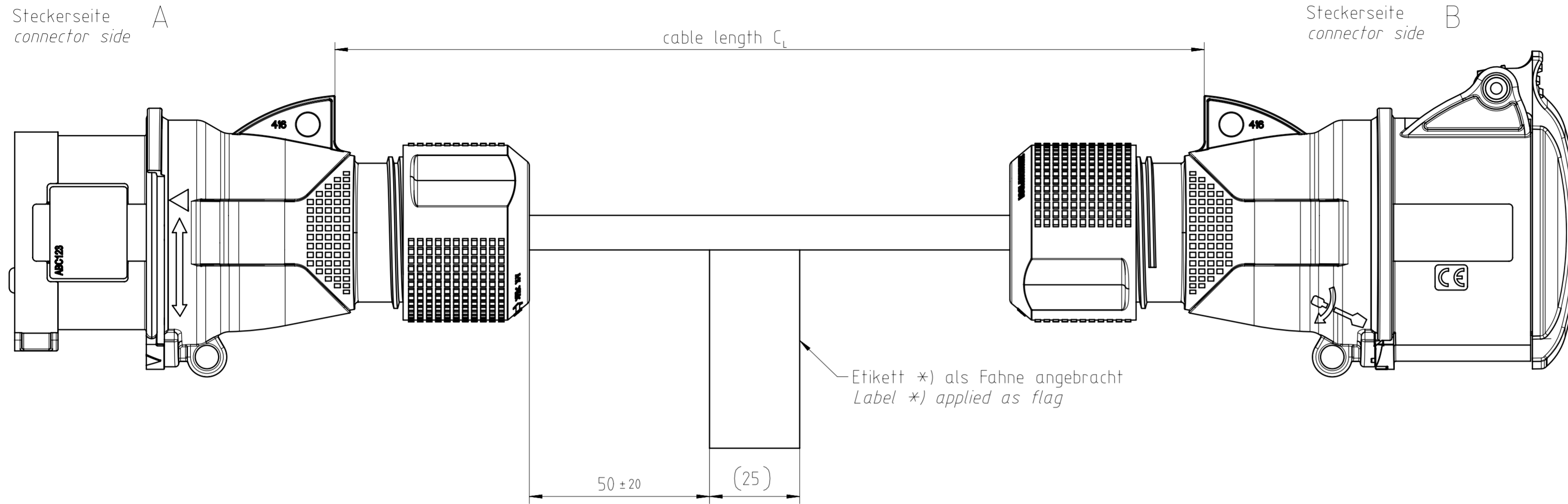

Pin assignment 3 Pin assembly

Connector side A	Wire colour	Open end
L	Brown	L
N	Blue	N
GND	Green-yellow	GND

Pin assignment 5 Pin assembly

Connector side A	Wire colour	Open end
L1	Brown	L1
L2	Black	L2
L3	Grey	L3
N	Blue	N
GND	Green-yellow	GND

Characteristic of cable assemblies

Part number	TYP	Voltage	Pole	Ampere (A)	Cable Length (m)	Cable Size	Cable Type	IP	Connector side A	Connector side B
CA 309 4016EP06100P 001	CEE	400V	5P	16	10	5G1,5	H07RN-F	IP44	416EP6 / 2CMA101967R1000	416EC6 / 2CMA102023R1000
CA 309 4016EP06150P	CEE				15	5G1,5				
CA 309 4016EP06200P 001	CEE				20	5G1,5				
CA 309 4016EP06250P	CEE				25	5G1,5				
CA 309 4016EV06050P	CEE Phase inverter				5	5G1,5				
CA 309 4016EV06100P	CEE Phase inverter				10	5G1,5				
CA 309 4016EV06150P	CEE Phase inverter				15	5G1,5				
CA 309 4016EV06200P	CEE Phase inverter				20	5G1,5				
CA 309 4016EV06250P	CEE Phase inverter				25	5G2,5				
CA 309 4016EV06500P	CEE Phase inverter				50	5G2,5				
CA 309 4016EP06050P	CEE				5	5G2,5				
CA 309 4016EP06100P	CEE				10	5G2,5				
CA 309 4016EP06150P 001	CEE				15	5G2,5				
CA 309 4016EP06200P	CEE				20	5G2,5				
CA 309 4016EP06250P 001	CEE				25	5G2,5				
CA 309 4032EP06050P	CEE				5	5G6				
CA 309 4032P06100P	CEE				10	5G6				
CA 309 2032P06150P	CEE				15	5G6				
CA 309 4032EP06200P	CEE				20	5G6				
CA 309 4032P06250P 001	CEE				25	5G6				
CA 309 4032P06500P	CEE	50	5G6							
CA 309 2016EP06050P	CEE	230V	3P	16	5	3G1,5	H07RN-F	IP44	216EP6 / 2CMA101947R1000	216EC6 / 2CMA102003R1000
CA 309 2016EP06100P	CEE				10	3G1,5				
CA 309 2016EP06150P	CEE				15	3G1,5				
CA 309 2016EP06200P	CEE				20	3G1,5				
CA 309 2016EP06050P 001	CEE				5	3G2,5				
CA 309 2016EP06100P 001	CEE				10	3G2,5				
CA 309 2016EP06200P 001	CEE				20	3G2,5				
CA 309 2016EP06250P	CEE				25	3G2,5				
CA 309 2016EP06500P	CEE				50	3G2,5				
CA 309 4032P06250P	CEE				400V	4P			32	



Gewicht (errechnet) / Calc. WT.:	Zul. Abw./Tolerances:	Maßstab / Scale: 1:1	A2
Prüfmaß / Testdimension:	DIN / ISO 13715	CUSTOMER DRAWING	
Teilindex / Partindexnumber:			
minor change:	Gez. Drawn: 30.07.2025 PKRCMARIK	VC CA IPS 16A + 32A	
	Status: in work	CEE extension cable cassy	
	Gepr. Checked:	M VC CA IPS 16A + 32A	
Amphenol Tuchel Industrial GmbH		Blatt / Sheet 1	
01 202500260 31.07.2025 PKRCM	Ers. f. / Replacement for:	1 Bl.	