



TYPE

PRODUCT SPECIFICATION

NUMBER

GS-12-389

TITLE

TwinBlade™ Power IO

PAGE

1 of 13

REVISION

D

AUTHORIZED BY

R.T. de Blicq

DATE

20-04-2009

CLASSIFICATION

Released

PN 10056526  
Longitudinal version cable connector



INSTANCE: GENERIC

PN 10066104  
Straight version cable connector

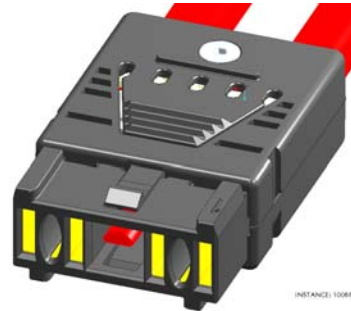

INSTANCE: 10066104

PN 51939-219  
Horizontal board connector



	TYPE <b>PRODUCT SPECIFICATION</b>	NUMBER <b>GS-12-389</b>	
TITLE <b>TwinBlade™ Power IO</b>		PAGE 2 of 13	REVISION D
		AUTHORIZED BY R.T. de Blieck	DATE 20-04-2009
		CLASSIFICATION <b>Released</b>	

**Table of contents.**

This document is composed of the following sections:

Paragraph	Title
1.0	OBJECTIVE
2.0	SCOPE
3.0	APPLICABLE DOCUMENTS
4.0	REQUIREMENT
5.0	ELECTRICAL CHARACTERISTICS
6.0	MECHANICAL CHARACTERISTICS
7.0	ENVIRONMENTAL CONDITIONS
8.0	QUALITY ASSURANCE PROVISIONS
9.0	REFERENCE DOCUMENTS
Table 1.	Qualification Testing Matrix

	TYPE	PRODUCT SPECIFICATION		NUMBER	GS-12-389	
	TITLE			PAGE		REVISION
<b>TwinBlade™ Power IO</b>			3 of 13		D	
			AUTHORIZED BY		DATE	
			R.T. de Blieck		20-04-2009	
			CLASSIFICATION			
			Released			

## 1.0 OBJECTIVE

This specification defines the performance, test and quality and reliability of the TwinBlade™ Power IO Connector family.

## 2.0 SCOPE

This specification is applicable to the Cable and Board Connectors with part numbers 10056526-xxxLF, 10066104-xxxLF and 51939-219LF

## 3.0 APPLICABLE DOCUMENTS

### 3.1 Specifications:

- a. Engineering drawing 10056526-xxxLF, 10066104-xxxLF, 51939-219LF

### 3.2 FCI specifications:

- a. BUS-03-404 Normal Force Measurement
- b. BUS-12-111 HPC Solderless (Press Fit) Right Angle
- c. GS-22-0007 Engineerings guidelines for RoHS information
- d. NC1-2722 Qualification Test Data

### 3.3 Other Standards en Specifications:

- a. IEC 60998-1
- b. IEC 60998-2
- c. UL 94 V-0: Flammability
- d. EIA 364: Test Procedure for Electrical Connectors, Sockets and Coaxial Contacts
- e. IEC 60950 Safety requirements

## 4.0 REQUIREMENTS

### 4.1 Qualification

Connectors furnished under thus specification shall be capable of meeting the qualification test requirements specified herein.

### 4.2 Material:

The materials for each component shall be specified herein or equivalent.  
 Power Contacts – Copper Base Alloy.  
 Board connector and Cable connector Housings – Glass Filled HTN (High Temperature Nylon)

### 4.3 Finish:

Min. 0,8µm Au over min. 1,27µm Ni in contact area.  
 Min. 2µm Sn on crimping area.

### 4.4 Design and Construction

Connectors shall be of the design, construction and physical dimensions specified on the applicable product drawings.

- a. See drawing number 10056526-xxxLF, 10066104-xxxLF, 51939-219LF

	TYPE	PRODUCT SPECIFICATION		NUMBER	GS-12-389	
	TITLE			PAGE	4 of 13	REVISION
<b>TwinBlade™ Power IO</b>			AUTHORIZED BY	R.T. de Blieck	DATE	20-04-2009
			CLASSIFICATION			Released

4.5 Workmanship includes freedom from blistering, cracks, discoloration, etc.

## 5.0 ELECTRICAL CHARACTERISTICS

### 5.1 Operating Voltage:

The operating voltage may not exceed 80V DC @25A for current interrupting applications. For non-interrupting applications, the operating voltage may not exceed 300V DC.

### 5.2 Current rating (Temperature rise):

The temperature rise above at ambient when using specified current in section 5.10

### 5.3 Connector resistance:

The total resistance over the mated connector after 50 operations during 20 years measured over the cable crimp and surface of PCB close to the pins shall not exceed 0.6mΩ.

### 5.4 UL1977 approval

The connector family is approved for UL1977 current interrupting applications in following conditions: 80V DC @ 25A and 25°C ambient temperature and 20V DC @ 100A and 25°C ambient temperature.

### 5.5 Hot Insertion:

The connector has to withstand minimal 50 mating powered operations over 20 years. The connectors has to withstand 200A at 0.5ms (capacitive load) powered operations for minimal 50 mating cycles. The connector may not exceed the maximum connector resistance. The mating/ unmating speed is maximum 750mm/s and minimum 50mm/s. After each mating and unmating cycle the load must be discharged.

### 5.6 Short Circuit Capacity:

The connector has to withstand 5 operations carrying 3000A for 10ms.

### 5.7 Dielectric Withstanding Voltage:

There shall be no evidence of arc-over, insulation breakdown, or excessive leakage current (>0.5mA) when the mated connectors are tested in accordance with EIA 364-20C. The following details shall apply:

Test voltage: Min. 744Vrms or 1052 VDC

Test duration: 60 seconds. According IEC60950-1

### 5.8 Insulation resistance

The insulation resistance of mated connectors shall not be less than 1 GΩ and after environmental exposure when measured in accordance with EIA 364 TP 21:

a. Test voltage 500 VDC

b. Electrification time – 2 minutes

c. Points of measurement – Between adjacent contacts

### 5.9 Contact mating sequence:

There is no mating sequencing in mating the connectors.

### 5.10 Max current per cable cross section:

25mm<sup>2</sup>: 100A

16mm<sup>2</sup>: 80A

2x6mm<sup>2</sup>: 75A

	TYPE	PRODUCT SPECIFICATION		NUMBER	GS-12-389	
	TITLE			PAGE		REVISION
<b>TwinBlade™ Power IO</b>			5 of 13		D	
			AUTHORIZED BY		DATE	
			R.T. de Blieck		20-04-2009	
			CLASSIFICATION			
			Released			

10mm<sup>2</sup>: 57.8A

## 6.0 MECHANICAL CHARACTERISTICS

- 6.1 Mating / Unmating force:  
 Perform in accordance with EIA 364-13B (Telcordia GR-1217,5,1,5:R5-23).  
 The force to mate the receptacle connector and compliant header shall not exceed 50N.  
 The force to unmate the receptacle connector and compliant header shall not be less than 15N and max 40N
- Cross Head Speed – 12.5mm/min.
  - Lubrication- None
  - Utilize free floating fixtures
- 6.2 Normal force  
 The contact normal force shall not be less than 3.5N per beam for the contacts when tested in accordance with FCI Test Specification BUS-03-404.
- 6.3 Tensile strength  
 The board connector has to withstand a tensile strength of 250N in 6 directions.
- 6.4 Latching:  
 The connector has an active locking system and the retention force must be min 70N max 150N initial and before rupture.
- 6.5 Polarizing:  
 There is a polarizing feature in the receptacle housing preventing 180 deg turned insertion of cable connector into the board connector. Polarization must withstand min 250N before rupture and mating.
- 6.6 PCB Hole Deformation Radius  
 Cross section parallel to board surface. Photograph and measure the hole deformation (deformation on board material) radius at a point .010" from the surface, and the centre of the compliant pin section. Include 10 holes. The average (of 10 holes) hole deformation radius shall be no greater than .0015" when measured from the drilled hole. The absolute maximum deformation radius shall not exceed .002".
- 6.7 PCB Hole Wall Damage  
 Cross section perpendicular to board surface, and through the compliant section wear track. Photograph and measure the copper thickness remaining between the compliant section and the printing wiring board laminate. Include 10 holes. The minimum average (of 10 holes) copper thickness remaining between the compliant pin and the printed wiring board laminate shall not be less than .0003". In addition there shall be no copper cracks, separations between conductive interfaces, or laminate-to-copper separations.
- 6.8 Coding  
 There is also a coding system to code the connectors. 4 coding sequences available.  
 Insertion with wrong coding key has to withstand a minimal force of 250N before rupture



TYPE  
**PRODUCT SPECIFICATION**

NUMBER  
**GS-12-389**

TITLE  
**TwinBlade™ Power IO**

PAGE  
6 of 13

REVISION  
D

AUTHORIZED BY  
R.T. de Blicq

DATE  
20-04-2009

CLASSIFICATION  
**Released**

6.9 Cable range for strain relief:

Wiresize [mm <sup>2</sup> ]	Jacket O.D. [mm]	
	Min	Max.
25	9.4	10.0
16	7.8	8.0
10	5.6	5.9
2x6	4.6	5.0

6.10 Conductor Area cable:  
10, 2x6, 16 and 25mm<sup>2</sup>

6.11 Touchproof

Board connector has to be protected according IEC 60998-1 + IEC 60668-2-2 applicable part (10N)  
Cable connector has to be protected according IEC 60998-1 + IEC 60668-2-2 applicable part (30N)

6.12 Robustness test.

The mated connector should withstand min Force on the location mentioned in table without rupture.

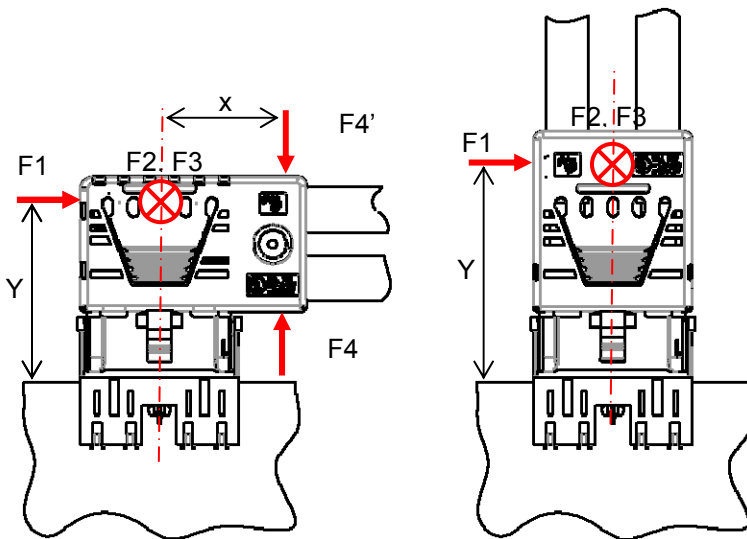



Fig.1.

	RA	Straight t
F1	350N	180N
F2/F3	200N	100N
F4	175N	Na
X	30mm	Na
Y	25mm	37mm

	TYPE	PRODUCT SPECIFICATION		NUMBER	GS-12-389		
	TITLE			PAGE	7 of 13		REVISION
<b>TwinBlade™ Power IO</b>			AUTHORIZED BY	R.T. de Blieck		DATE	20-04-2009
			CLASSIFICATION			Released	

## 7.0 ENVIROMENT CONDITIONS.

After exposure of the following conditions as specified in “Table 1 – Test Sequences” in accordance with specified test and/or details, the products shall show no physical damage and shall meet the electrical and mechanical requirements in section 6 and 7. Unless specified otherwise the products shall be mated during exposure.

- 7.1 Thermal Shock- EIA 364 32C
  - a. Test condition 36, 1 hour cycles
  - b. Temperature Range: -20 to +75°C
  - c. Time at each Temperature- 30 minutes minimum
  - d. Transfer Time – 5 Minutes, maximum.
  
- 7.2 Humidity, Steady State – EIA 364 31B, Method II
  - a. Relative Humidity - 95%
  - b. Temperature +40°C
  - c. Test duration – 96 hours
  
- 7.3 High Temperature Life, EIA 364 17B
  - a. Test duration – 21 Days
  - b. Temperature 105°C
  
- 7.4 Industrial Mixed Flowing Gas (IMFG) (4 gases, classII) (GR-1217-CORE, Issue 1) – Mated and unmated test samples were exposed to an industrial gas mixture for 10 days according to GR-1217-CORE, section 9.1.3, Central Office requirements. The temperature in the test chamber was 30 °C and the relative humidity 70 % RH.
  
- 7.5 Vibration Sinusoidal
 

Perform vibration test according IEC 60068-2-6 mated with 100A load.  
 Sinus frequency 10-150-10, 20 sweep each axis 40m/s2.  
 There shall be no specific or significant frequency’s generated from the connector during sinus vibration that can disturb other units in operation.
  
- 7.6 Mechanical Shock IEC 60068-2-27
  - a. Condition I (50G, 11 millisecond half sine wave)
  - b. Shocks 3 shocks in both directions along each of three orthogonal axis (18 total).
  - c. Mounting- rigidly mount assemblies
  - d. No discontinuities of greater than 20Ω may occur
  
- 7.7 Durability- Standard laboratory procedure as applicable to the specific product
  - a. Number of cycles – 50
  - b. Manual mated
  
- 7.8 Resistance to solder Heat – EIA 364-56
  - a. Test condition – Reflow soldering temperature min. 235°C and Max 260°C for 10 seconds.
  - b. There shall be no evidence of physical or mechanical damage.
  
- 7.9 Operating temperature -20°C to +75°C

	TYPE	PRODUCT SPECIFICATION		NUMBER	GS-12-389	
	TITLE			PAGE		REVISION
<b>TwinBlade™ Power IO</b>			8 of 13		D	
			AUTHORIZED BY		DATE	
			R.T. de Blieck		20-04-2009	
			CLASSIFICATION			
			Released			

- 7.10 Cable retention:  
The strain relief tensile force on the cable must be min 250N for the complete connector.  
The 2x6mm<sup>2</sup> has a min of 100N per 2 cables.
- 7.11 Storage temp range  
Storage temp range in packed condition of -40°C to 85°C. testduration 100Hours  
After test the connector should be assembled and the contact resistance should be within specification.
- 7.12 Non Destruction in unpacked or mounted position:  
Z/AD test (IEC-60068-2-38) with temperatures of -35°C to +75°C humidity 96% for the duration of 10 days. After test the connector should be assembled and the contact resistance should be within specification.

## 8.0 QUALITY ASSURANCE PROVISIONS

- 8.1 Equipment Calibration  
All test equipment and inspection facilities used in the performance of any test shall be maintained in a calibration system in accordance with ISO 9000
- 8.2 Inspection conditions
  - a. Unless otherwise specified, all inspections shall be performed under the following conditions:
  - b. Temperature: 25 +/- 5°C
  - c. Relative humidity: 30 to 60%
  - d. Barometric Pressure: Local ambient
- 8.3 Sample Quality and Description
- 8.4 Acceptance
  - a. Electrical and Mechanical requirements shall be as indicated in Paragraphs 6.0 and 7.0 using test data and appropriate statistical technique.
  - b. Failures attributed to equipment, test setup or operator error shall not disqualify the product.
- 8.5 Qualification Testing  
Qualification testing shall be performed on sample units predicted with equipment and procedures normally used in production. Test sequence is as shown in Table 1.
- 8.6 Re-qualification Testing
  - a. If any of the following conditions occur, the responsible product engineer shall initiate re-qualification testing of the applicable parts of the test matrix, Table1. A significant design change is made to the existing product that impacts the product form, fit or function. Examples of significant, changes shall include, but not be limited to, changes shall include, but not be limited to, changes in the plating material composition or thickness, contact force or contact surface geometry, insulator design, contact base material or contact lubrication requirements.
  - b. A significant event occurs during production or end use requiring corrective action to be taken relative to the design or manufacturing process.
  - c. A significant change is made to the manufacturing process that impacts the product form, fit and function.

	TYPE <b>PRODUCT SPECIFICATION</b>	NUMBER <b>GS-12-389</b>	
	TITLE <b>TwinBlade™ Power IO</b>	PAGE 9 of 13	REVISION D
AUTHORIZED BY R.T. de Blicck		DATE 20-04-2009	
CLASSIFICATION <b>Released</b>			

8.7 Sample Size:  
 Test group 1-6, 7c and 9-12 will require all R/A and Straight wire sizes to be tested.  
 Test Group 7a, 7b and 8 will require each style (R/A & Straight ) to be tested.

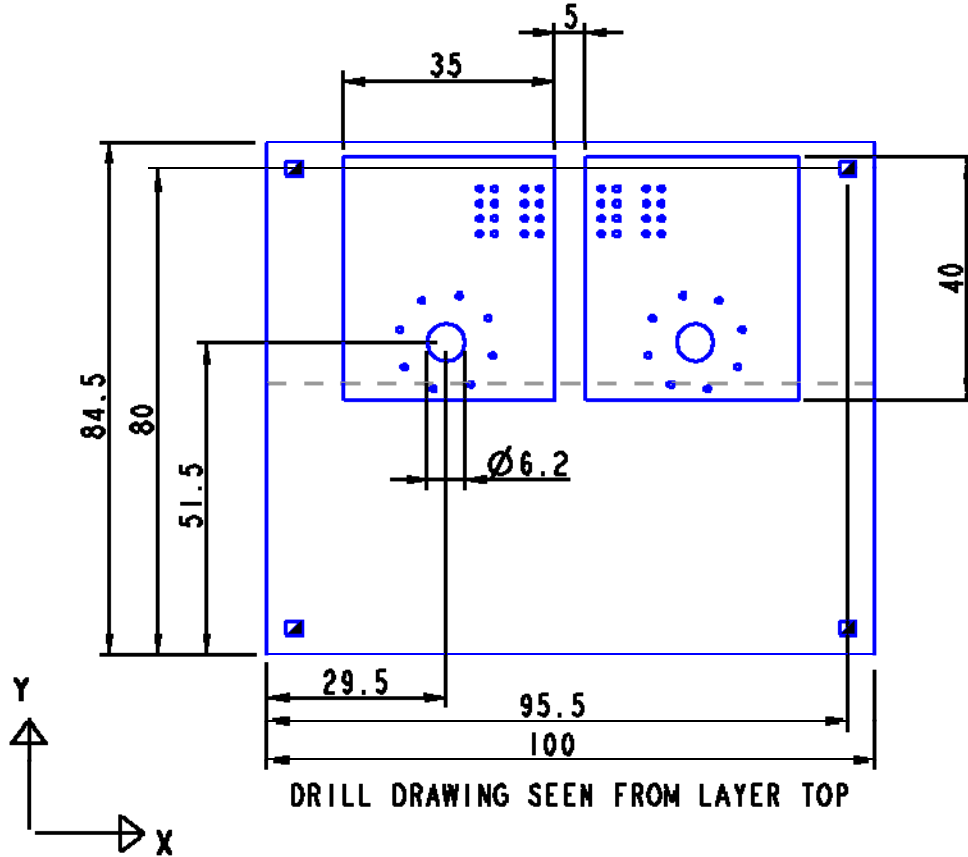

PCB Layout of current rating test

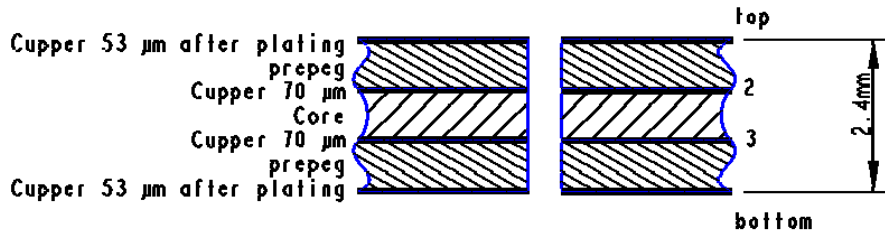

Manufacturer is allowed to use standard build-up

Fig.2.



TYPE  
**PRODUCT SPECIFICATION**

NUMBER  
**GS-12-389**

TITLE  
**TwinBlade™ Power IO**

PAGE  
10 of 13

REVISION  
D

AUTHORIZED BY  
R.T. de Blicck

DATE  
20-04-2009

CLASSIFICATION  
**Released**

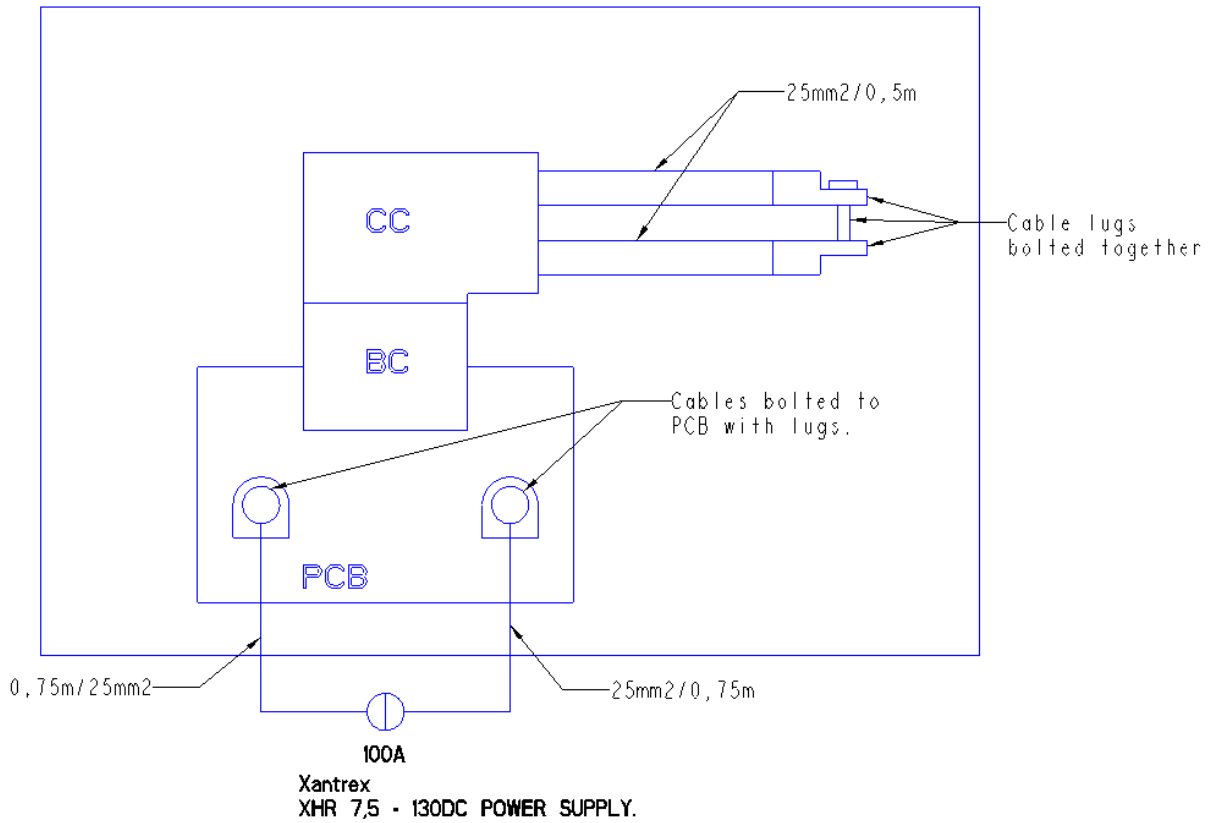

Diagram of the test setup of the current rating

Fig.3.



TYPE

**PRODUCT SPECIFICATION**

NUMBER

**GS-12-389**

TITLE

**TwinBlade™ Power IO**

PAGE

11 of 13

REVISION

D

AUTHORIZED BY

R.T. de Blicck

DATE

20-04-2009

CLASSIFICATION

**Released**

Table 1

Test Sequence Matrix																	
Quantity Mated Pairs <sup>1</sup>		5	5	5	5	5	5	5	5	3	3	5	3	5	5	5	5
Test Description	Par.	1	2a	2b	2c	3	4	5	6	7a	7b	7c	8	9	10	11	12
Visual examination of product	4.5	1 15	1 10	1 11	1 10	1 8	1 6	1 8	1 8	1 7	1 3	1 7	1 3	1	1	1 4	1 4
Temperature rise	5.2								2 5 7								
Contact resistance	5.3	3 5 7 11 13	3 5 8	3 6 9	3 5 8		2 5	2 7				2 6				3	3
Hot insertion	5.5	9	4	4				4	3								
Short circuit capacity	5.6			5	4				4								
Dielectric Withstanding Voltage	5.7					3 7											
Insulation Resistance	5.8					2 6		3 6									
Mating/Unmating Force	6.1	2 8 10 14	2 6 9	2 7 10	2 6 9												
Contact normal force	6.2													2			
Latch release force	6.4									2 4 6							
Durability	7.7									3							
Cable retention	7.10											3 5					
Connector robustness	6.12										2						
Touch proof	6.11														2		
Thermal shock	7.1	4				4											
Humidity, steady state	7.2	6				5											
High temperature life	7.3	12						5		5		4					
Ind. Mixed flowing gas	7.4		7	8	7				6								
Vibration	7.5						3										
Mechanical Shock	7.6						4										
Thermal Shock	7.11															2	
Z/AD test	7.12																2
Resistance to solder heat	7.8												2				

<sup>1</sup> sample size see section 8.7



TYPE

PRODUCT SPECIFICATION

NUMBER

GS-12-389

TITLE

TwinBlade™ Power IO

PAGE

12 of 13

REVISION

D

AUTHORIZED BY

R.T. de Blieck

DATE

20-04-2009

CLASSIFICATION

Released

### Derating Curve

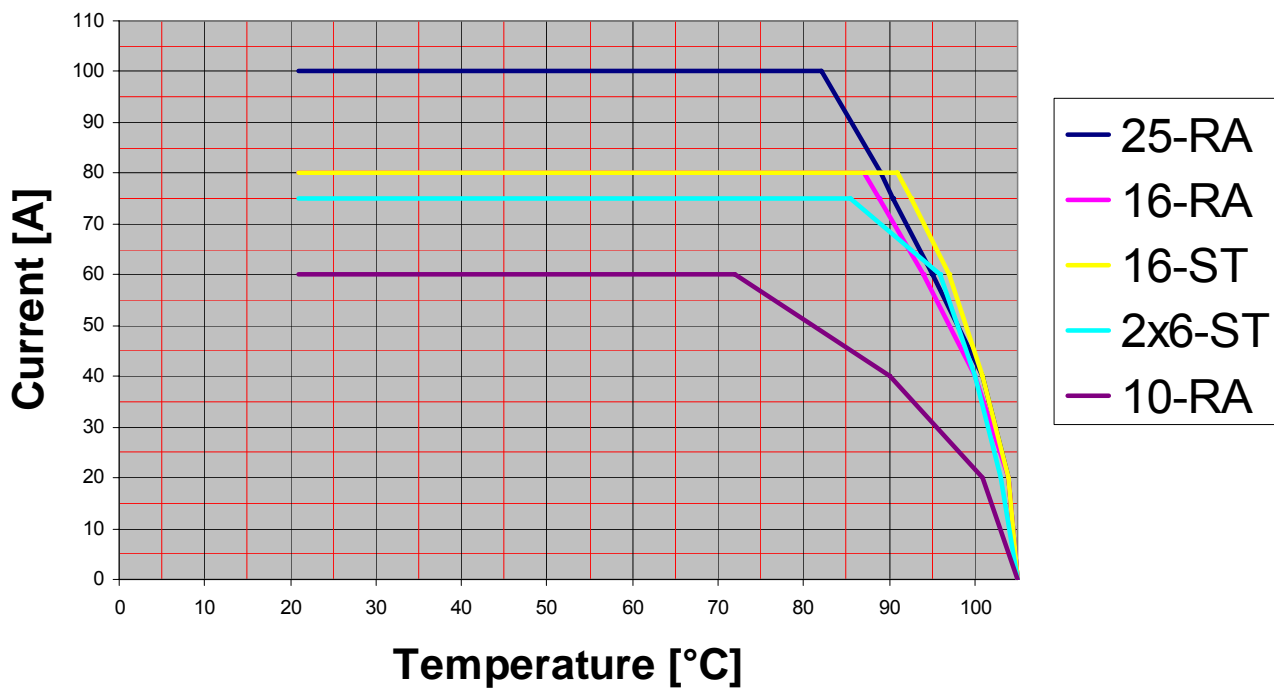

	TYPE <b>PRODUCT SPECIFICATION</b>	NUMBER <b>GS-12-389</b>	
TITLE <b>TwinBlade™ Power IO</b>		PAGE 13 of 13	REVISION D
		AUTHORIZED BY R.T. de Blieck	DATE 20-04-2009
		CLASSIFICATION <b>Released</b>	

## 9.0 REVISION RECORD

REV	PAGE	DESCRIPTION	ECP	DATE
A	All	Release the product specification	H07_0037	15/02/2007
B	All		H07-0078	16/05/2007
C	All		H09-0005	09/01/2009
D	All	Changes made for 10mm RA;	H09-0062	20/04/2009