

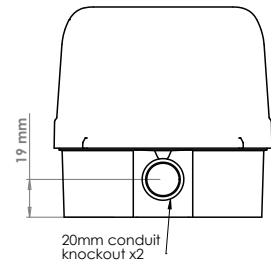

Visual Signals - Industrial LED TRAFFIC LIGHT

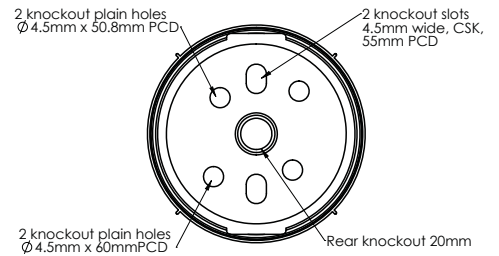
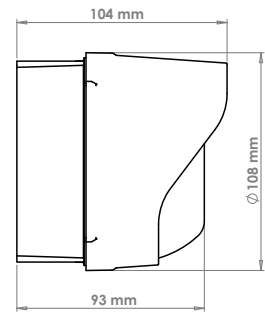

Industrial LED Traffic Light > LED TL Series - Surface Mount

Product overview

The LED Traffic Light has been designed for industrial & commercial applications where a low maintenance, long life & cost effective solution for car park management, factory traffic control & automated gate & door control systems is required.

The traffic light units are suitable for indoor or outdoor applications and incorporate 36 high output LED's. They can be surface mounted onto any flat vertical surface or conduit box and used as a stand-alone module. Alternatively, the modular design of the traffic light

allows for multiple units to be pre-assembled by the installer to create a multiple indication light system. Each unit comes supplied as standard with all components required for multiple assembly for surface mount installation.

These units require external input signals or PLC control to switch visual indication functions (not supplied). However, the amber light incorporates an optional jumper link on the PCB that allows the unit to flash once energised.

Cable termination is inside the enclosure and can be accessed via either the 2 x M20 conduit knockouts (top or bottom) or 1 x M20 rear conduit entry.

Features

- Continuously rated
- LED long life & extra bright
- Low current consumption
- Suitable for conduit box or wall mounting
- 120° prime light output above the vertical axis
- Multiple modular construction option
- 1, 2 or 3 bracket mounting option
- Dustproof and Weatherproof

Material

UV Stable ABS Plastic Base
UV Stable Polycarbonate Lens & Shroud

LED TL Series > Ordering Information

Code No:	Voltage:	Light Source:	Current:
LED-TL-01	8-20v Ac/Dc ~	36 SMT LEDs	240mA @ 12v Dc
LED-TL-02	20-30v Ac/Dc ~	36 SMT LEDs	120mA @ 24v Dc
LED-TL-03	35-85v Ac/Dc ~	36 SMT LEDs	76mA @ 48v Dc
LED-TL-05	40-380v Dc --- 85-280v Ac -	36 SMT LEDs	35mA @ 230v Ac

ADD THE FOLLOWING LENS CODES TO THE PRODUCT WHEN ORDERING **01** **02** **04**

Kg 0.26 each

50/60 Hz

°C -25+55

IP 65



APPROVALS and
CONFORMITIES



Multiple Modular Assembly Options & Electrical Control

Each individual TL module is supplied as standard with an adaptor kit that allows for the construction of multiple units. Surplus components can be recycled. The adaptor kit consists of 1 x M20 male/male adaptor, 2 x locknuts & 2 x external sealing washers

For Multiply Assemblies

1. Remove appropriate M20 knockouts on the side of the bases to allow for multi base connection.
2. Remove appropriate M20 knockout for power input into one base.
3. Remove appropriate knockouts for fixing/mounting points to be used.

Connect modules as required using the adaptor kit(s) supplied. Do not overtighten the locknuts. Secure at least one base (more if desired or possible) to a vertical mounting point or conduit box utilising mounting gasket(s) supplied.

Control & termination connectors are on each PCB inside each unit and can take up to 2.5mm² stranded cable and allows for loop in / loop out connection if required.

In addition, optional mounting brackets are available to mount single, double or triple units. This allows the units to be off set against the mounting structure giving the traffic light module(s) 180° angle of movement, optimising the visual indication position.

Alternatively, factory assembled & pre-wired units incorporating mounting brackets can be purchased complete. See website for further details.

Double Traffic Light, Surface Mount

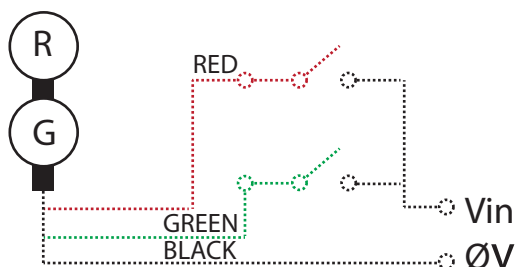
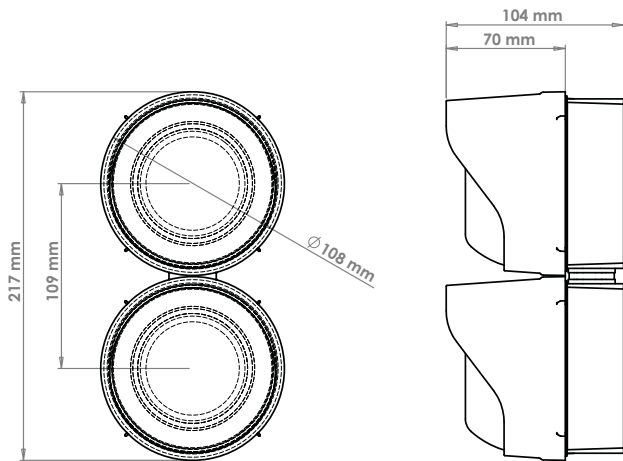

Triple Traffic Light, Surface Mount

