

SMD CURRENT SENSE METAL CHIP RESISTOR

TYPE TLM SERIES

INTRODUCTION

TE Connectivity (TE) has extended our low ohmic metal chip resistor TLM series with the High Power TLMQ. This series is designed for current sense circuits in power electronic systems which now also has a more advanced primary overcoat applied on both its top and bottom side which offers higher reliability, accuracy and durability. Supplied as standard on tape and reel for automatic insertion processes.



FEATURES

- Low resistance resistor for current detection
- Small size to power ratio
- Metal foil construction ensures high reliability and performance with very low and stable TCR
- Designed for current sense circuits in power electronic systems
- Pb-Free to meet RoHS Requirements
- High Power Series AEC-Q200 Compliant
- Moisture Sensitivity Level - MSL1

Note: SMD (Surface mount devices) resistors and inductors should be kept in their original packaging to protect them from ESD (Electrostatic Discharge). The full reels can be broken into smaller quantities, without exposing them to ESD, as long as the components are still in the plastic or paper tape. These resistors and inductors should not be removed from the plastic or paper tape unless they are in an ESD protected environment.

APPLICATIONS

- Power Management Applications
- Switching Power Supply
- Over Current Protection in Audio Applications
- Voltage Regulation Module (VRM)
- DC-DC Converter, Battery Pack, Charger, Adaptor

SMD Current Sense Metal Chip Resistor

Type TLM Series

ELECTRICAL CHARACTERISTICS

Standard Series

Type	Power Rating @ 70°C	Operating Temp. Range	Resistance Range (mΩ)		TCR (PPM/°C)	Weight (mg)
			±1%	5%		
TLM1J	0.125 W	-55~+155°C	10 - 19		±100	2.63
			20 - 100		±50	2.53
TLM2A	0.25 W		10 - 19		±100	
			20 - 100		±50	5.63
TLM2B	0.5 W		10 - 19		±100	
			20 - 100		±50	11.63
TLM2H	0.75 W		10 - 19		±100	
			20 - 100		±50	28.35
TLM3A	1 W		10 - 19		±100	
			20 - 100		±50	43.49
					±100	

Operating Voltage= $\sqrt{P \cdot R}$; Overload Voltage= $2.5 \cdot \sqrt{P \cdot R}$; Operating Current= $\sqrt{P/R}$

High Power Series

Type	Power Rating @ 70°C	Operating Temp. Range	Max. Overload Current	Resistance Range (mΩ)		TCR (PPM/°C)	Weight (mg)	
				±1%	±5%			
TLMQ1J	0.5 W	-55~+170°C	15.8 A	10 - 18		±100	2.63	
				19 - 100			2.53	
TLMQ2A	0.75 W		19.4 A	10 - 18		±50	6.24	
				19 - 100			5.63	
TLMQ2B	1 W		22.4 A	10 - 18			±50	13.30
				19 - 100				11.63
TLMQ2H	1.5 W		27.4 A	10 - 18			±50	31.42
				19 - 100				28.35
TLMQ3A	2 W		28.3 A	10 - 18			±50	45.21
				19 - 100				43.49

SMD Current Sense Metal Chip Resistor

Type TLM Series

ENVIRONMENTAL CHARACTERISTICS

Standard Series

Item	Requirement	Test Method
Temperature Coefficient of Resistance (TCR)	As Spec.	JIS-C-5201-1 4.8 IEC-60115-1 4.8 -55°C-+125°C, 25°C is the reference temperature
Short Term Overload	$\pm(0.5\%+0.05\Omega)$	JIS-C-5201-1 4.13 IEC-60115-1 4.13 2512 size: 4 X Rated Power for 5 seconds Other size: 5 X Rated Power for 5 seconds
Insulation Resistance	$\geq 10G$	JIS-C-5201-1 4.6 IEC-60115-1 4.6 Max. overload voltage for 1 minute
Endurance	$\pm(1.0\%+0.05\Omega)$	MIL-STD-202 Method 108A 70 \pm 2°C, RCWV for 1000 hrs with 1.5 hrs "ON" and 0.5 hrs "OFF"
Damp Heat with Load	$\pm(1.0\%+0.05\Omega)$	JIS-C-5201-1 4.24 IEC-60115-1 4.24 40 \pm 2°C, 90-95% R.H. RCWV for 1000 hrs with 1.5 hrs "ON" and 0.5 hrs "OFF"
Dry Heat	$\pm(0.5\%+0.05\Omega)$	JIS-C-5201-1 4.23 IEC-60115-1 4.23.2 at +155°C for 1000 hrs
Bending Strength	$\pm(1.0\%+0.05\Omega)$	JIS-C-5201-1 4.33 Bending once for 60 seconds 2010, 2512 sizes: 2mm Other sizes: 3mm
Solderability	95% min. coverage	JIS-C-5201-1 4.17 IEC-60115-1 4.17 245 \pm 5°C for 3 seconds
Resistance to Soldering Heat	$\pm(0.5\%+0.05\Omega)$	JIS-C-5201-1 4.18 IEC-60115-1 4.18 260 \pm 5°C for 10 seconds
Voltage Proof	No breakdown or flashover	JIS-C-5201-1 4.7 IEC-60115-1 4.7 1.42 times Max. Operating Voltage for 1 minute
Leaching	Individual leaching area $\leq 5\%$ Total leaching area $\leq 10\%$	JIS-C-5201-1 4.18 IEC-600068-2-58 8.2.1 260 \pm 5°C for 30 seconds
Rapid Change of Temperature	$\pm(0.5\%+0.05\Omega)$	JIS-C-5201-1 4.19 IEC-60115-1 4.19 -55°C to +155°C, 5 cycles

Storage Temperature: 25 \pm 3°C; Humidity < 80%RH

Shelf Life: 2 years from production date

SMD Current Sense Metal Chip Resistor

Type TLM Series

High Power Series

Item	Requirement	Test Method
Temperature Coefficient of Resistance (TCR)	As Spec.	JIS-C-5201-1 4.8 IEC-60115-1 4.8 -55°C-+125°C, 25°C is the reference temperature
Short Term Overload	$\Delta R \leq \pm 1\%R$	JIS-C-5201-1 4.13 IEC-60115-1 4.13 5 X Rated Power for 5 seconds 2512 size: 4* Rated Power for 5 seconds Other size: 5* Rated Power for 5 seconds
Insulation Resistance	$\geq 1000MG$	JIS-C-5201-1 4.6 IEC-60115-1 4.6 Max. overload voltage for 1 minute
Operational Life	$\Delta R \leq \pm 1\%R$	MIL-STD-202 Method 108 Condition D Steady State $T_A = 125^\circ C$ at derated power. Measurement at 24 \pm 4 hours after test conclusion
Biased Humidity	$\Delta R \leq \pm 1\%R$	MIL-STD-202 Method 103 85°C/85R.H., 1000 hrs apply 10% of operating power (current) or limiting element current whichever is lower
High Temperature Exposure	$\Delta R \leq \pm 1\%R$	MIL-STD-202 Method 108 At +155°C for 1000 hours
Temperature Cycling	$\Delta R \leq \pm 1\%R$	JESD22 Method JA-104 -55°C to +125°, 1000 cycles
Bending Strength (Board Flex)	$\Delta R \leq \pm 1\%R$	JIS-C-5201-1 4.33 Bending once for 60 seconds 2010, 2512 sizes: 2mm Other sizes: 3mm
Solderability	95% min. coverage	JIS-C-5201-1 4.17 IEC-60115-1 4.17 245 \pm 5°C for 3 seconds
Resistance to Soldering Heat	$\Delta R \leq \pm 1\%R$	JIS-C-5201-1 4.18 IEC-60115-1 4.18 260 \pm 5°C for 10 seconds
Voltage Proof	No breakdown or flashover	JIS-C-5201-1 4.7 IEC-60115-1 4.7 1.42 times Max. Operating Voltage for 1 minute
Resistance To Solvents	Marking unsmearred	MIL-STD-202 Method 215 Add Aqueous wash chemical – OKEM Clean or equivalent. Do not use banned solvents
Mechanical Shock	$\Delta R \leq \pm 1\%R$	MIL-STD-202 Method 213 Wave Form: Tolerance for half sine shock pulse. Peak value is 100g's. Normal duration (D) is 6
Vibration	$\Delta R \leq \pm 1\%R$	MIL-STD-202 Method 204 5 g's for 20 min. 12 cycles each of 3 orientations, 10-2000 Hz
ESD	$\Delta R \leq \pm 1\%R$	AEC-Q200-002 Human body model 2KV
Flammability	No ignition of the tissue paper or scorching of the pinewood board	UL-94 V-0 or V-1 are acceptable. Electrical test not required
Terminal Strength	Not broken	AEC-Q200-006 Force of 1.8kg for 60 seconds

Storage Temperature: 15-28°C; Humidity < 80%RH
Shelf Life: 2 years from production date

SMD Current Sense Metal Chip Resistor

Type TLM Series

DERATING CURVE

Standard Series

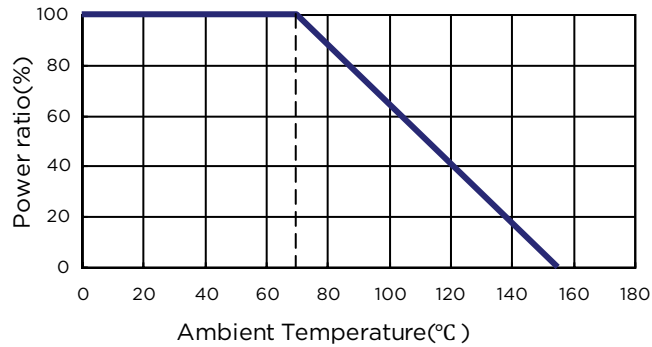

High Power Series

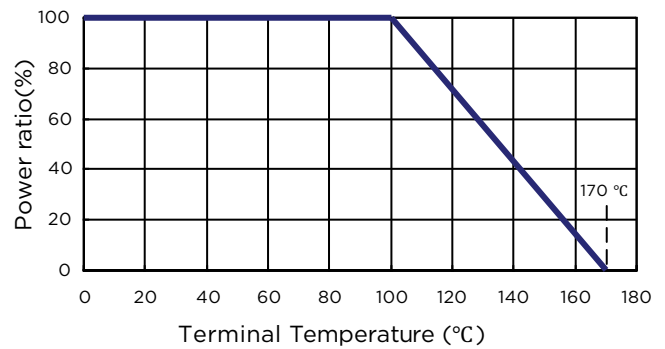
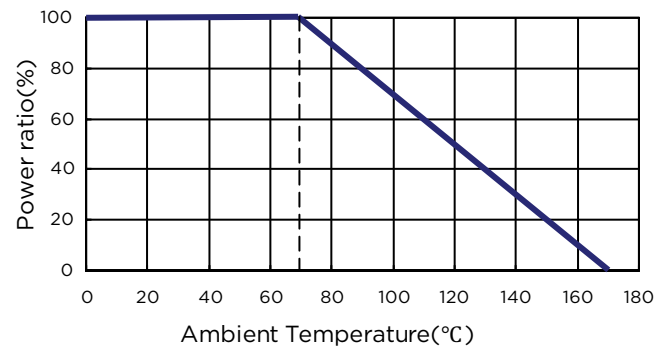

Note: For resistors operated at an ambient temperature of 70°C or higher, the power rating shall be derated in accordance with the above derating curve.

CONSTRUCTION AND DIMENSIONS

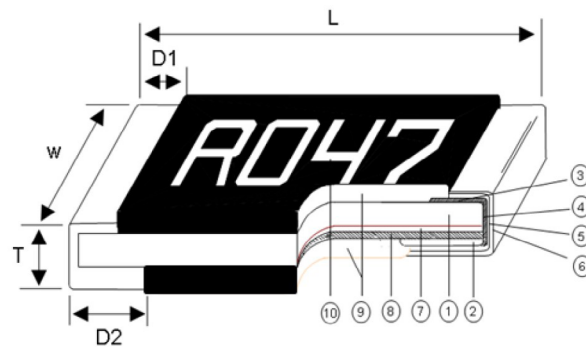

1	Alumina Substrate	5	Barrier Layer (Ni)	9	Primary Overcoat (Epoxy)
2	Bottom Electrode (Cu)	6	External Electrode (Sn)	10	Marking (Epoxy)
3	Top Electrode (NiCr)	7	Adhesive (Acrylic)		
4	Edge Electrode (NiCr)	8	Resistor Layer (Alloy)		

SMD Current Sense Metal Chip Resistor

Type TLM Series

Type	Resistance Range (mΩ)	L	W	T	D1	D2
TLM(Q)1J	10 - 18	1.60±0.15	0.85±0.15	0.45±0.15	0.30±0.25	0.35±0.25
	19 - 100	1.60±0.15	0.85±0.15	0.40±0.15	0.30±0.25	0.35±0.25
TLM(Q)2A	10 - 18	2.05±0.15	1.25±0.15	0.60±0.15	0.30±0.25	0.35±0.25
	19 - 100	2.05±0.15	1.25±0.15	0.60±0.15	0.30±0.25	0.35±0.25
TLM(Q)2B	10 - 18	3.10±0.15	1.55±0.15	0.60±0.15	0.50±0.25	0.60±0.30
	19 - 100	3.10±0.15	1.55±0.15	0.60±0.15	0.50±0.25	0.60±0.30
TLM(Q)2H	10 - 18	5.00±0.20	2.50±0.20	0.60±0.15	0.60±0.30	0.80±0.30
	19 - 100	5.00±0.20	2.50±0.20	0.60±0.15	0.60±0.30	0.80±0.30
TLM(Q)3A	10 - 18	6.40±0.20	3.20±0.20	0.60±0.15	0.70±0.30	0.80±0.30
	19 - 100	6.40±0.20	3.20±0.20	0.60±0.15	0.70±0.30	0.80±0.30

RECOMMENDED LAND PATTERN (Unit:mm)

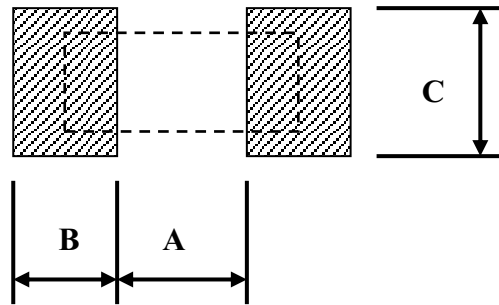

Type	Resistance Range (mΩ)	A	B	C	t (μm)
TLM(Q)1J	10 - 100	0.70	1.05	0.90	35
TLM(Q)2A	10 - 100	1.00	1.00	1.35	70
TLM(Q)2B	10 - 100	1.50	1.40	1.70	105
TLM(Q)2H	10 - 100	2.80	1.80	2.50	105
TLMQ3A	10 - 100	3.80	2.25	3.20	105

t: Copper foil minimum thickness of PCB

MARKING

FOR TLM(Q)1J

Type	Code
R10	0.100Ω
R01	0.010Ω
035	0.035Ω
005	0.005Ω

FOR TLM(Q)2A -TLM(Q)3A

Type	Code
R100	0.100Ω
R050	0.050Ω
R010	0.010Ω
R005	0.005Ω

SMD Current Sense Metal Chip Resistor

Type TLM Series

SOLDERING REFLOW PROFILE

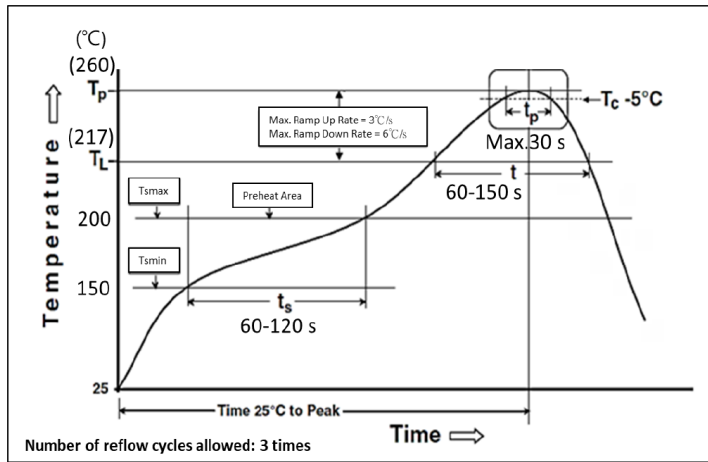

Profile Feature	Pb-Free Assembly
Preheat	
Min. Temperature (T_{smin})	150 °C
Max Temperature (T_{smax})	200 °C
Preheating time (t_p) from (T_{smin} to T_{smax})	60-120 seconds
Ramp-up rate (T_L to T_p)	3 °C/second max.
Liquidous temperature (T_L)	217 °C
Time (t_L) maintained above T_L	60-150 seconds
Min. Peak temperature (T_p min)	235 °C
Max. Peak temperature (T_p max)	260 °C
Time (t_p) within 5 °C of the specified classification temperature (T_c)	30 seconds max.
Ramp-down rate (T_p to T_L)	6 °C/second max.
Time 25 °C to peak temperature	8 minutes max.

PACKAGING

Packaging Quantity and Reel Dimensions (mm)

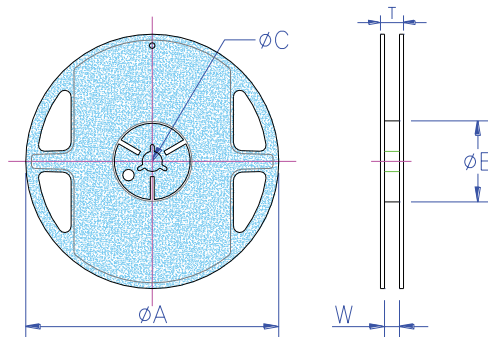

Type	ΦA	ΦB	ΦC	W	T	Paper Tape (EA)	Embossed Plastic Tape (EA)
TLM(Q)1J	178.0±1.0	60.0±1.0	13.5±0.7	9.5±0.1	11.5±1.0	5,000	-
TLM(Q)2A	178.0±1.0	60.0±1.0	13.5±0.7	9.5±0.1	11.5±1.0	5,000	-
TLM(Q)2B	178.0±1.0	60.0±1.0	13.5±0.7	9.5±0.1	11.5±1.0	5,000	-
TLM(Q)2H	178.0±1.0	60.0±1.0	13.5±0.7	13.5±1.0	15.5±1.0	-	4,000
TLM(Q)3A	178.0±1.0	60.0±1.0	13.5±0.7	13.5±1.0	15.5±1.0	-	4,000

SMD Current Sense Metal Chip Resistor

Type TLM Series

Paper Tape Dimensions (mm)

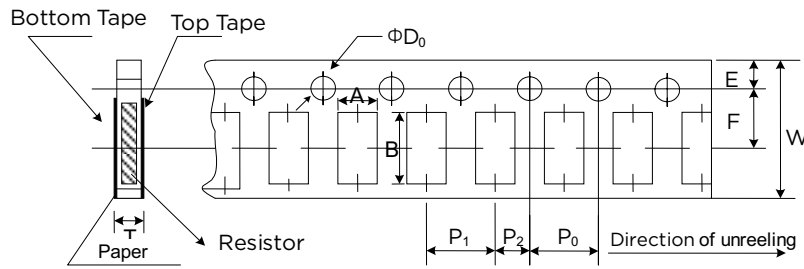

Type	A	B	W	E	F	P ₀	P ₁	P ₂	ΦD ₀	T
TLM(Q)1J	1.10 ±0.10	1.85 ±0.10	8.0 ±0.20	1.75 ±0.10	3.50 ±0.05	4.00 ±0.10	4.00 ±0.05	2.00 ±0.05	1.50 +0.1 -0	0.60 ±0.10
TLM(Q)2A	1.60 ±0.10	2.35 ±0.20	8.0 ±0.20	1.75 ±0.10	3.50 ±0.05	4.00 ±0.10	4.00 ±0.05	2.00 ±0.05	1.50 +0.1 -0	0.95 ±0.10
TLM(Q)2B	1.90 ±0.10	3.50 ±0.20	8.0 ±0.20	1.75 ±0.10	3.50 ±0.05	4.00 ±0.10	4.00 ±0.05	2.00 ±0.05	1.50 +0.1 -0	0.95 ±0.10

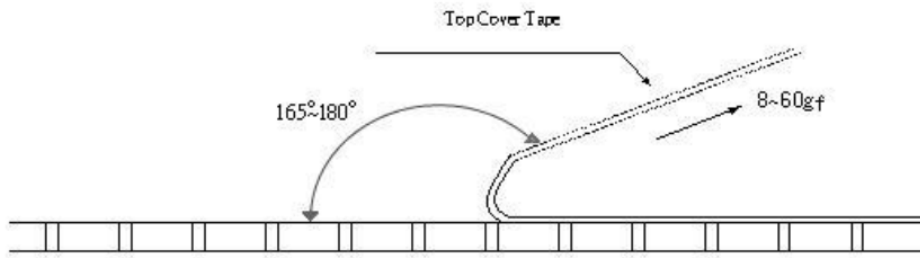

- Peel force of top cover tape
- The peel speed shall be about 300 mm/min±5%
- The peel force of top cover tape shall be between 8gf to 60gf

Embossed Plastic Tape Dimensions (mm)

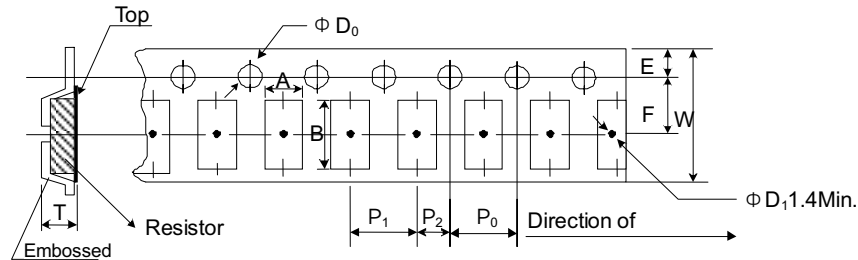

Type	A	B	W	E	F	P ₀	P ₁	P ₂	ΦD ₀	T
TLM(Q)2H	2.80 ±0.10	5.50 ±0.10	12.0 ±0.10	1.75 ±0.10	5.50 ±0.05	4.00 ±0.05	4.00 ±0.10	2.00 ±0.05	1.50 ±0.10	1.00 ±0.20
TLM(Q)3A	3.50 ±0.10	6.70 ±0.20	12.0 ±0.10	1.75 ±0.10	5.50 ±0.05	4.00 ±0.05	4.00 ±0.10	2.00 ±0.05	1.50 ±0.10	1.00 ±0.20

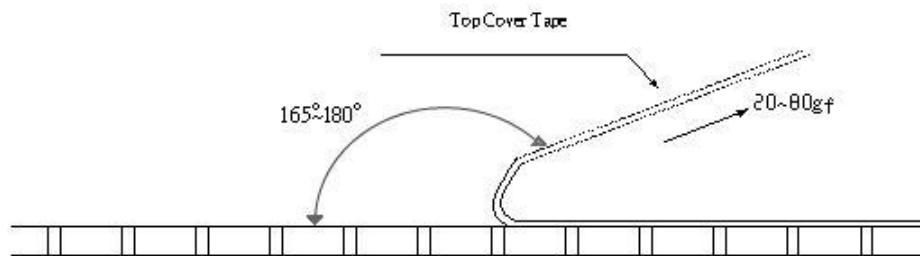

- Peel force of top cover tape
- The peel speed shall be about 300 mm/min ±5%
- The peel force of top cover tape shall be between 20 gf to 80 gf

ORDERING INFORMATION

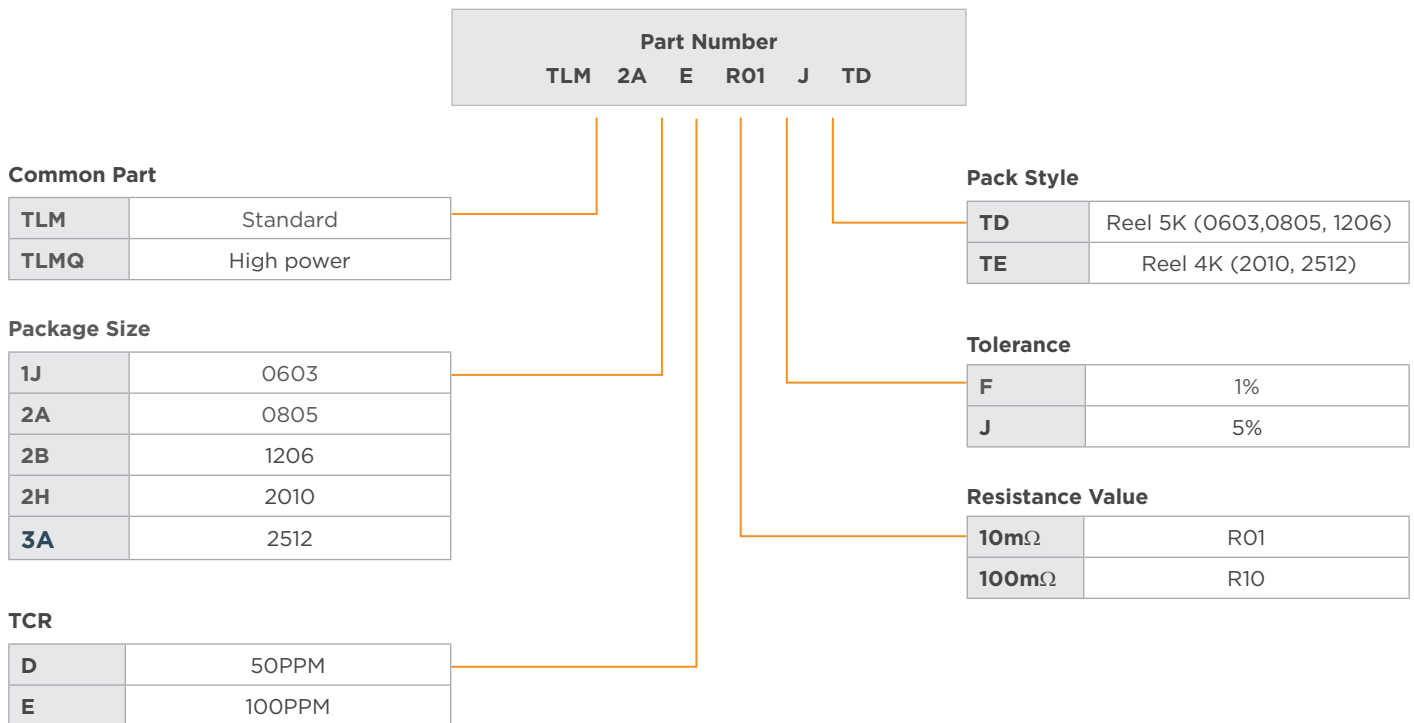

te.com

©2025 TE Connectivity plc. family of companies. All Rights Reserved.

TE Connectivity, TE connectivity (logo) and Every Connection Counts are trademarks owned or licensed by the TE Connectivity plc. family of companies. All other logos, products and/or company names referred to herein might be trademarks of their respective owners.

While TE has made every reasonable effort to ensure the accuracy of the information in this document, TE does not guarantee that it is error-free, nor does TE make any other representation, warranty or guarantee that the information is accurate, correct, reliable or current. TE reserves the right to make any changes to the information contained herein without prior notice. TE Connectivity assumes only those obligations set forth in the terms and conditions for this product and shall in no event be liable for any incidental, indirect, or consequential damages arising out of the sale, resale, use, or misapplication of the product. TE expressly disclaims any implied warranties with respect to the information contained herein, including, but not limited to, implied warranties of merchantability or fitness for a particular purpose. Dimensions, specifications and/or information contained herein are for reference purposes only and are subject to change without notice. Consult TE for the latest dimensions, specifications and/or information. Users of TE Connectivity products must make their own assessment as to whether the respective product is suitable for the respective desired application.

02/25 1773269-1 REV:C ED