

9.0 End of Line Monitoring

An End of Line monitoring Diode or an End of Line monitoring Resistor can be connected across the 24V+ and 0 terminals. Resistor values for the End of Line will be determined by the customer with a minimum value of 1.2kΩ

10.0 Maintenance

Little or no maintenance is required during the normal working life of the product. The Moflash Exd enclosures are resistant to most acids, alkalis and chemicals and have been designed to withstand severe weather conditions. However it is suggested that to avoid the possibility of a potential electrostatic charge build up, the exterior of the product is periodically wiped down with a clean damp cloth. At this point a visual inspection is recommended to ensure that the product is in good working order and no damage has been sustained during its normal operation.

11.0 Conditions for Safe Usage

i) This apparatus is suitable to be used only in ambient temperature as stated below:

Type	Ambient Temp
BC125	-40°C to +70°C

ii) Do not paint or change the surface finish of the unit. The coating applied by the manufacturer is Anti-Static & UV Stable.

iii) Repairs of the flameproof joints must be made in compliance with the structural specifications provided by the manufacturer. Repairs must not be made on the basis of values specified in tables 1 and 2 of EN/IEC 60079-1.



INSTALLATION & TECHNICAL INFORMATION

PLEASE READ PRIOR TO INSTALLATION



BC125 Series - (Explosion Proof Beacon)

Stainless Steel

VISUAL SIGNALLING DEVICES

APPROVALS AND
CONFORMITIES



1.0 Introduction

The BC125 range is certified for use and installation in Zone 1 and Zone 2 with gas groups IIA, IIB, IIC, also Zones 21 and 22 for Dust. The unit carries a temperature classification of T4~T6. It especially applies to Oil & Gas, Offshore Platform, Chemical, Petrochemical, Refinery and Marine Industries etc. Enclosure material is Stainless Steel. Different flash or rotary rate can be adjusted from unique design. Three working statuses; flash type, rotary type and steady type are available (LED). There are two types of beacon (Xenon type and LED type) available for the customer.

2.0 Explosion-Proof Labelling

All products have a rating label with the following important information:

Product order no: eg BC125RX05DCNNNAR (Refer to the datasheet for product order selection)

Input voltage: 12-48v DC or 100-240v AC (50/60 Hz), ≤25W

Code: Ex d IIC T4~ T6 Gb, Ex tb IIIC T135°C~T85°C IP66

Nemko ATEX Certificate No: Nemko 14ATEX 1011X

ATEX Mark:



IECEX Certificate: IECEX-NEM 14.0007X

Gas Group and Category: II 2GD

CE Mark: Mark No: 0518

Warning: **DO NOT OPEN WHEN AN EXPLOSIVE GAS ATMOSPHERE IS PRESENT**

Finished product serial no (Include date of construction): ie. BC125-10201080001
BC125-Stainless Steel Beacon & Light: **Day**-02, **Month**-01, **Year**-08, **Product Serial Number**-0001

Table 2 - Xenon Beacon Frequency and Status Selection

All values in () are the numbers of flashes per time

DIP Switch		S1/S2	S1=OFF S2=OFF	S1=ON S2=OFF	S1=OFF S2=ON	S1=ON S2=ON
1st DIP	2nd DIP	Alarm Stage 1	Alarm Stage 2	Alarm Stage 3	Alarm Stage 4	
0	0	OFF	60 times/min (1)	90 times/min (1)	120 times/min (1)	
1	0	OFF	60 times/min (2)	60 times/min (3)	60 times/min (4)	
0	1	OFF	60 times/min (3)	60 times/min (4)	60 times/min (5)	
1	1	OFF	60 times/min (4)	60 times/min (5)	60 times/min (6)	

8.0 Cable Gland

The BC125 series product has four cable gland entries. Only cable glands approved for Exd applications can be used with Moflash Explosion Proof Products, these must be suitable for the type of cable being used and also meet the requirements of the Exd flameproof installation standard EN 60079-14.

SAFETY WARNING

If units are used at high ambient temperatures, i.e. over +40°C then the cable entry temperature may exceed +70°C and therefore suitable heat resisting cable glands must be used, with a rated service temperature of at least 95°C.

If a high IP (Ingress Protection) rating is required, a suitable sealing washer must be fitted under the cable gland. Any unused cable entry holes must be closed with an Exd flameproof blanking plug, which must be suitably approved for the installation requirements.

The gland accessories below offer a wide selection to cover most Ex environments.

Gland and Plug Options	
50200: M20 E1EX Nickel Plated Brass Gland	50210: M20 E1EX Stainless Steel Gland
50201: M20 A2EX Nickel Plated Brass Gland	50211: M20 A2EX Stainless Steel Gland
50202: M20 E1EX-QS Nickel Plated Brass Gland	50212: M20 E1EX-QS Stainless Steel Gland
50203: M20 A2EX Quick Stop Nickel	50213: M20 A2EX Quick Stop
50204: M20 Nickel Plated Brass Stopping Plug	50214: M20 Stainless Steel Stopping Plug

7.0 Alarm Status, Flash Pattern & Frequency Adjustment (Refer tables 1 & 2)

Flash Pattern/Frequency are set using the **DIP Switches-SW1** (Picture 2) located on the pcb in the top cover of the flameproof enclosure.

LED Beacon: 3pole. Xenon Beacon: 2 pole. Binary code used in the tables: **0 = Off** and **1 = On/(High)**. **Alarm Status:** set via remote switching. **Factory Pre-set for Stage 2 Alarm.**

Picture 1 - BASE PCB

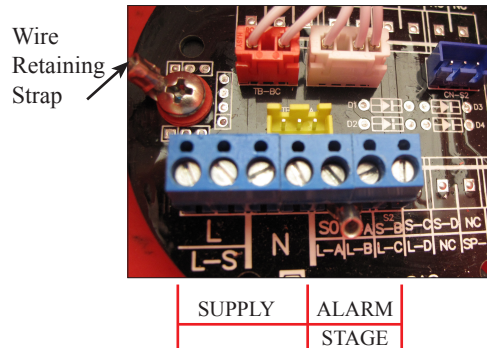

Picture 2 - TYPICAL COVER PCB

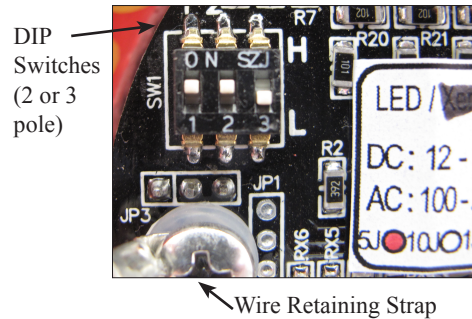

Table 1 - LED Beacon Frequency and Status Selection Values in () rate when 3rd DIP (1) On

DIP Switch			S1/S2	S1=OFF S2=OFF	S1=ON S2=OFF	S1=OFF S2=ON	S1=ON S2=ON
1st DIP	2nd DIP	3rd DIP	Alarm Stage 1	Alarm Stage 2	Alarm Stage 3	Alarm Stage 4	
0	0	0(1)	OFF	Flash 60 (75) times/min	Flash 75 (90) times/min	Steady light	
1	0	0(1)	OFF	Rotary 60 (75) times/min	Rotary 75 (90) times/min	Steady light	
0	1	0(1)	OFF	Triple Flash 60 (75) times/min	Triple Flash 75 (90) times/min	Triple Flash 100 (120) times/min	
1	1	0(1)	OFF	Flash & Rotary 60 (75) times/min	Flash & Rotary 75 (90) times/min	Flash & Rotary 100 (120) times/min	

3.0 Type Approval Standard

The Moflash product range all have an EC Type Examination Certificate issued by Nemko and have been approved to the following standards:

EN 60079-0:2012 (IEC 60079-0:2011), EN-60079-1:2007 (IEC 60079-1:2007)
EN 60079-31:2009 (IEC 60079-31:2008)

4.0 Zones, Gas Group, Category and Temperature Classification

The BC125 series products have been certified Ex d IIC T4~T6.

This means that the units can be installed in locations with the following conditions:

Area Classification:

Zone 1: Explosive gas air mixture likely to occur in normal operation.

Zone 2: Explosive gas air mixture not likely to occur, and if it does, it will only exist for a short time.

Gas Groupings

IIA Propane Group, IIB Ethylene Group, IIC Hydrogen and Acetylene

Zone 21: Explosive dust air mixture likely to occur in normal operation.

Zone 22: Explosive dust air mixture not likely to occur, and if it does, it will only exist for a short time.

Equipment Category: 2GD

Temperature Range: $-40^{\circ}\text{C} < T_a < 70^{\circ}\text{C}$

5.0 Installation

General Requirement

The product must be installed in accordance with the latest EN60079-0 and EN60079-1 specification or the equivalent IEC specification. Product installation must be carried out in accordance with any local codes that may apply and should only be carried out by a competent electrical engineer.

Location

The location of the unit should be chosen with due regard to the area over which the beacon warning signal must be visible/audible. The unit should only be fixed to services that can support the weight of the unit.

Mounting

The product should be mounted on a vertical surface using four fixing holes in the base. The fixing holes are designed to fit M5 Allen Screw only. Use of stainless steel fastener is recommended by Moflash. The beacon can be operated in any attitude. If you need a mounting plate, please contact Moflash to ask for the mounting plate installation drawing (see picture 1).

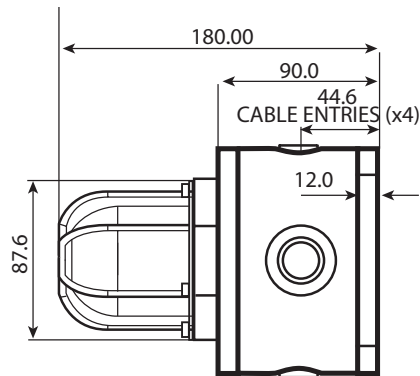

Picture 1

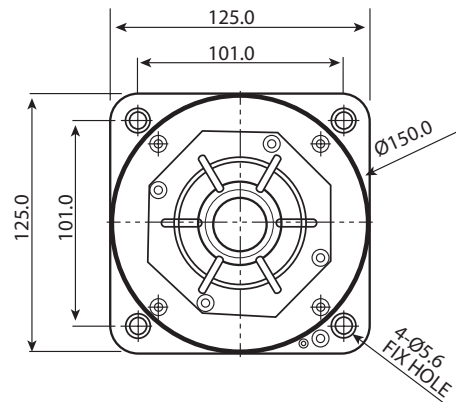

6.0 Wiring

General Requirement

Moflash recommends that all cables and cores should be fully identified (suggest using cable from 2.0 to 2.5 mm²). Ensure that all nuts, bolts and screws are secured. Ensure that only the right and certified cable glands are used and earthed correctly. Ensure that only the right and certified stopping plugs are used to blank off unused gland entry points. In order to maintain the IP rating of the product, we recommend SS316 for this application.

Cable Connection

The Supply and Alarm Status cable is connected to the terminals located in the flameproof enclosure base (Picture 1 and separate wiring drawing).

For **AC Supply** –to terminals marked **L & N**.
Terminals provide loop in loop out facility.

For **DC Supply** - connect “+” to **L** and “0” to **N**.

Alarm Status - to terminals marked ‘**S0**’ (common) & ‘**S1**’, ‘**S2**’
(Refer clause 7.0 - see tables).

Do not connect Ac or Dc to terminals **S0, S1, S2**

Removal of Top Cover (Beacon Component)

Unscrew the four (4) M5 retained Hexagon socket head screws. Twist the cover gently clockwise and anti-clockwise, whilst pulling away from the body, keeping the cover parallel to the body until it comes free. This will allow the cover to hang on its retaining strap. Before replacing the cover, check that the flameproof joints are clean and not damaged, the gasket is still retained in its groove.

CAUTION: Before removing the cover, ensure the power to the beacon is isolated.