

Dial v1.1

SKU:K130-V11

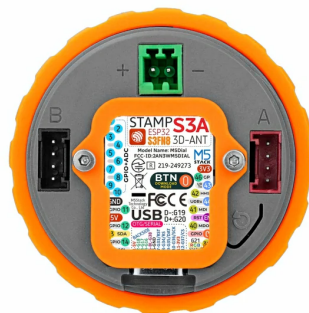

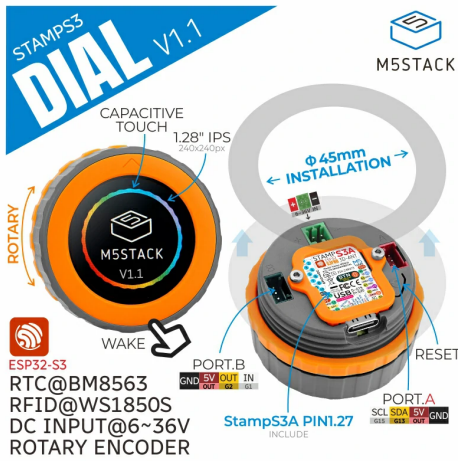
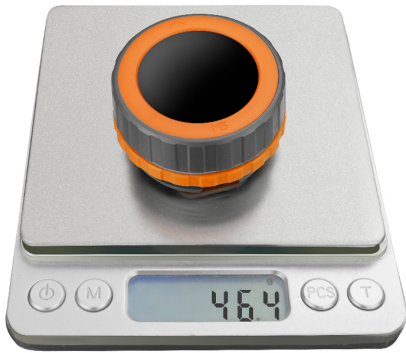

Description

Dial v1.1 is a high-performance, multifunctional embedded development board that has been fully upgraded from the original Dial product. The new version features the **Stamp-S3A** as the main controller, further enhancing system processing power and stability. Additionally, the core module antenna and buttons have been optimized to effectively improve wireless communication performance and user interaction experience. The product is equipped with a **1.28-inch** round TFT touch screen and a high-precision rotary encoder, and includes an **RFID** detection module, RTC circuit, onboard **buzzer**, and **under-screen buttons** to enable device interaction and wake-up alerts. The power supply solution supports **DC 6 ~ 36V** wide voltage input and includes a lithium battery interface and **charging** circuit to meet diverse application needs. Furthermore, the reserved PORT.A and PORT.B interfaces facilitate the expansion of I2C and GPIO devices. This product is applicable in smart home control, IoT applications, smart wearables, access control systems, industrial control, and educational maker projects.

Tutorial



Arduino IDE

This tutorial will guide you on how to program and control the Dial v1.1 device using Arduino IDE



UiFlow2

This tutorial will guide you on how to control the Dial v1.1 device using the UiFlow2 graphical programming platform

Features

- Round TFT touch screen
- Stamp-S3A as the main controller
- Rotary encoder
- RFID detection module
- Wide voltage input
- Interface expansion: Reserved PORT.A and PORT.B interfaces
- Development Platform

- UiFlow2
- Arduino IDE
- ESP-IDF
- PlatformIO

| Includes

- 1 x Dial V1.1
- 1 x L-shaped 1.5mm hex wrench (compatible with M2 screws)
- 1 x 2.54-2P terminal

| Applications

- Smart home control
- IoT projects
- Access control systems
- Industrial control

| Specifications

Specification	Parameter
SoC	ESP32-S3FN8@Dual-core Xtensa LX7, 240MHz
USB	USB OTG, USB Serial/JTAG
Flash	8MB
Wi-Fi	2.4 GHz Wi-Fi
Wide Voltage Input Range	DC 6 ~ 36V
Screen Driver	GC9A01 1.28 Inch 240 x 240px
Touch Driver	FT3267
RFID	WS1850S @ Tag operating frequency: 13.56 MHz, ISO/IEC 14443 Type A/Type B protocol
Encoder	Resolution: 16 positions, 64 pulses/rev
Buzzer	80dB
Battery Socket Specification	1.25mm-2P
Sleep Current	USB supply: DC 5V@6.84mA (LDO idle power consumption) Battery only: DC 4V@6uA
Operating Current	USB supply: DC 5V@88.19mA Battery only: DC 4V@100mA
Power Interface Specification	Model KF2EDGV-2.54-2P, straight pin design, 2.54mm pitch (2Pin), green
Operating Temperature	0 ~ 40°C
Product Size	51.0 x 51.0 x 32.3mm
Product Weight	46.2g
Package Size	71.9 x 71.9 x 57.4mm
Gross Weight	61.0g

Learn

Power On/Off

Power On/Off

Power On: When there is no external USB power supply (battery only), the device can be woken up by pressing the "WAKE" button or by an IRQ signal triggered by the RTC timer. After waking up, the HOLD (GPIO46) pin must be set to high (1) during program initialization to maintain power, otherwise the device will re-enter sleep mode.

Power Off: Similarly, when there is no external USB power supply (battery only), the device can be turned off by pressing the RST button or by setting the HOLD (GPIO46) pin to low (0) in the program.

Download Mode

Download Mode

To enter download mode, hold the G0 button on the Stamp-S3A before powering on, then release it after power is applied.

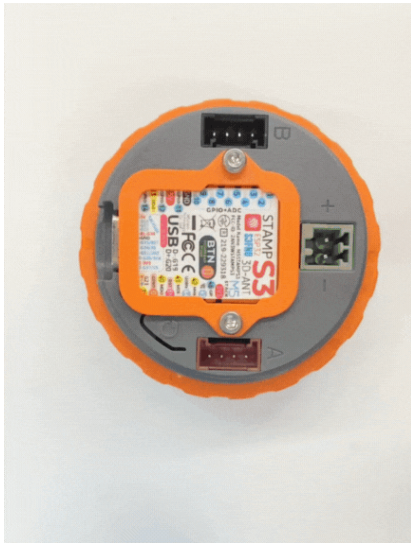

Dial v1.1 Lithium Battery Expansion Interface

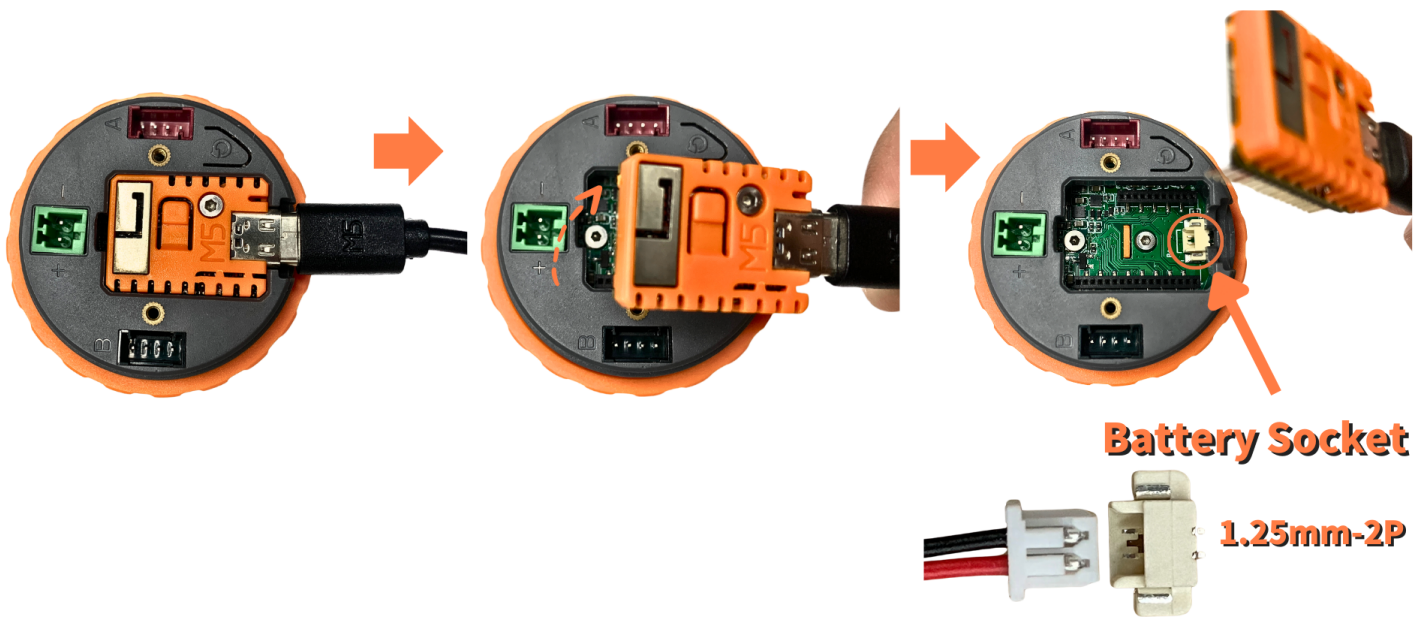

| RFID Card

If the size of the RFID tag is smaller than the outer dimensions of the Dial, it may not be recognized or may cause communication errors. It is recommended to use an RFID card in the standard bank card size.

| Schematics

- [Dial v1.1 Schematics PDF](#)

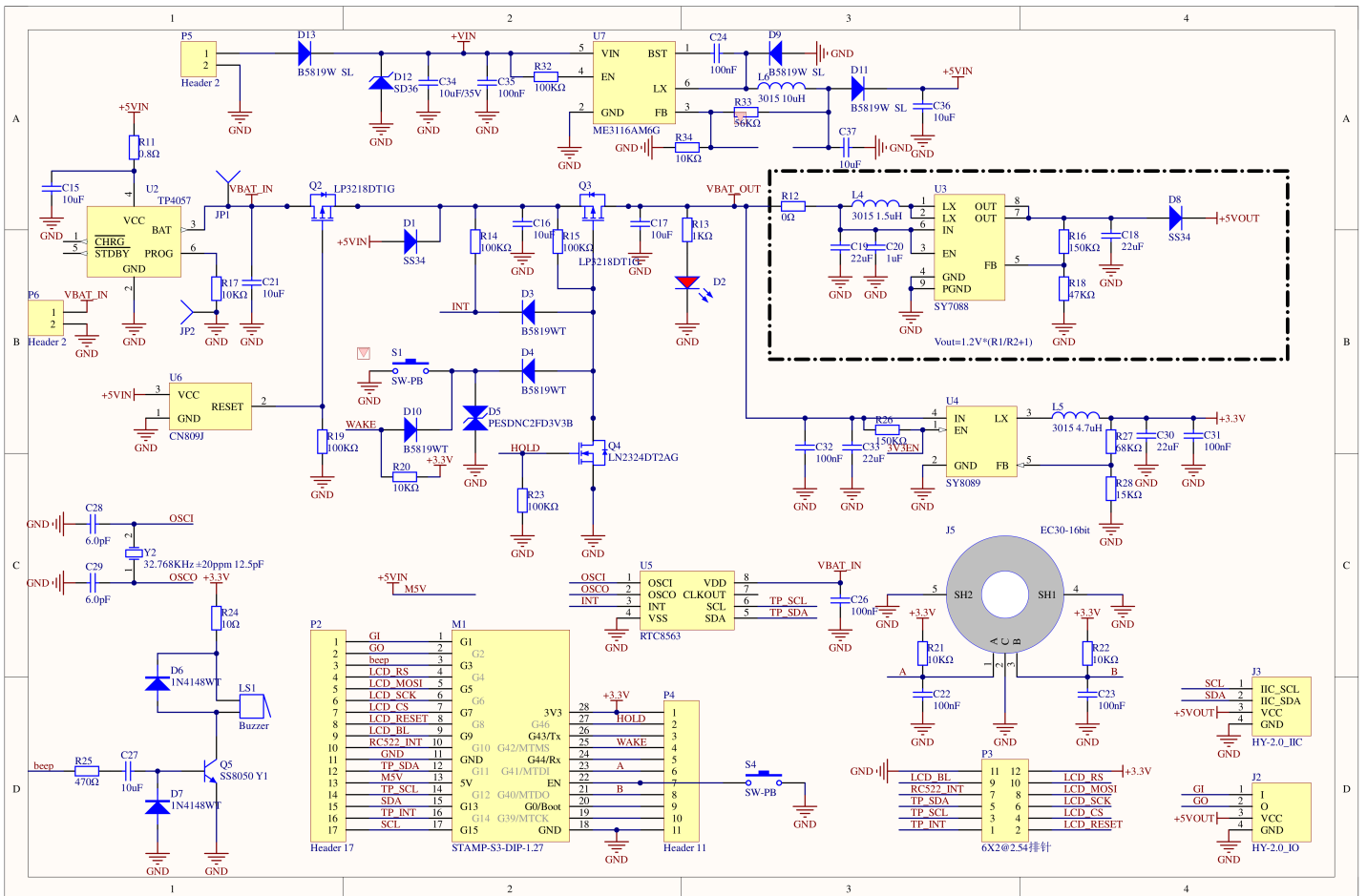
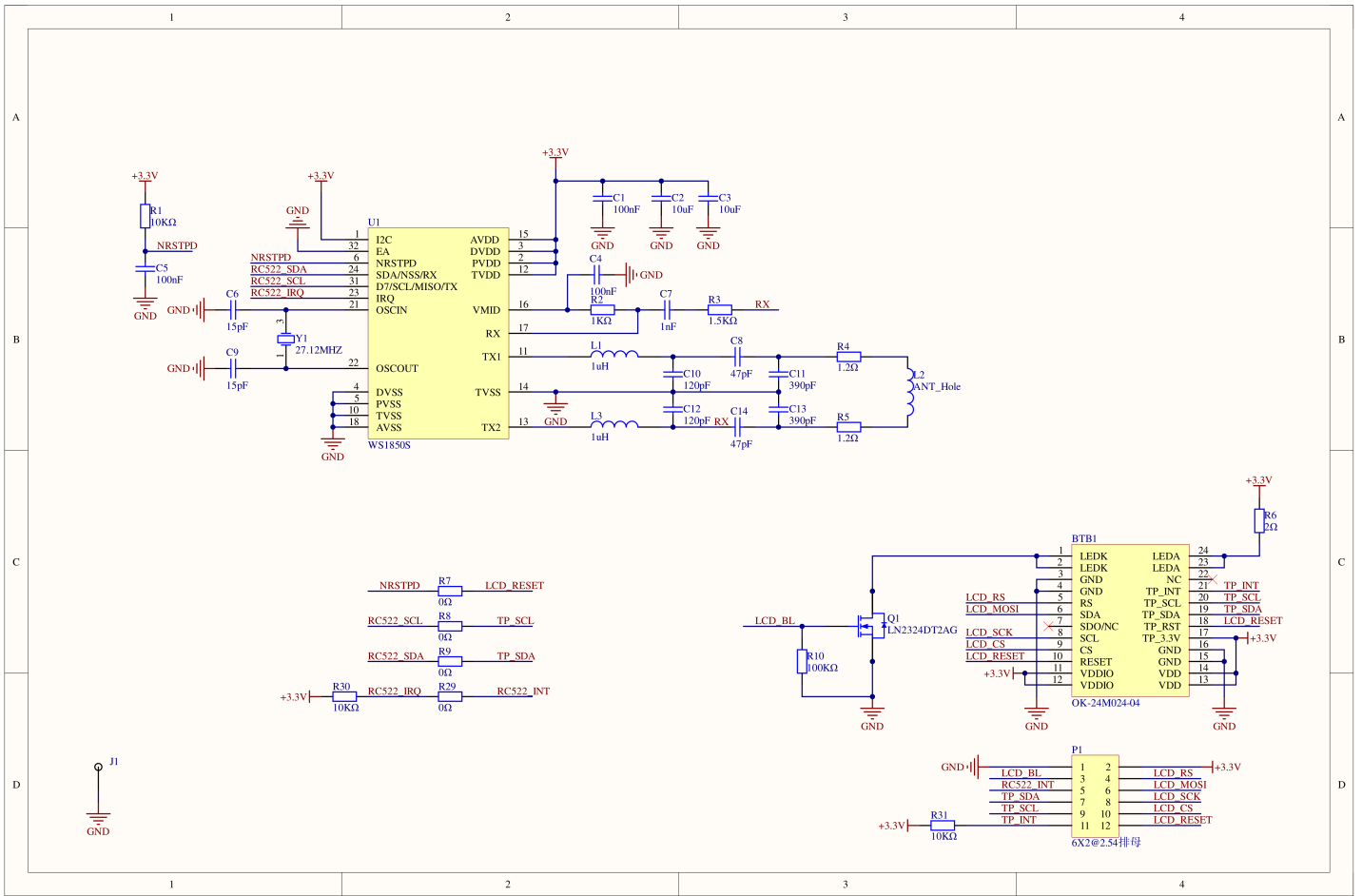

PinMap

I2C Sensor (RTC8563 & WS1850S)

ESP32-S3	G12	G11	G8	G10	G3
RTC8563	SCL	SDA			
WS1850S(RFID)	SCL	SDA	RST	IRQ	
Buzzer					beep

ENCODER

ESP32-S3	G40	G41	VCC	GND
ENCODER	B	A	5V	GND

Screen Driver (GC9A01-SPI) & Touch Driver

ESP32-S3	G4	G5	G6	G7	G8	G9	G11	G12	G14
GC9A01	LCD_RS	LCD_MOSI	LCD_SCK	LCD_CS	LCD_RESET	LCD_BL			
FT3267							TP_SDA	TP_SCL	TP_INT

HY2.0-4P

HY2.0-4P	Black	Red	Yellow	White
PORT.A	GND	5V	G13	G15
PORT.B	GND	5V	G2	G1

Model Size

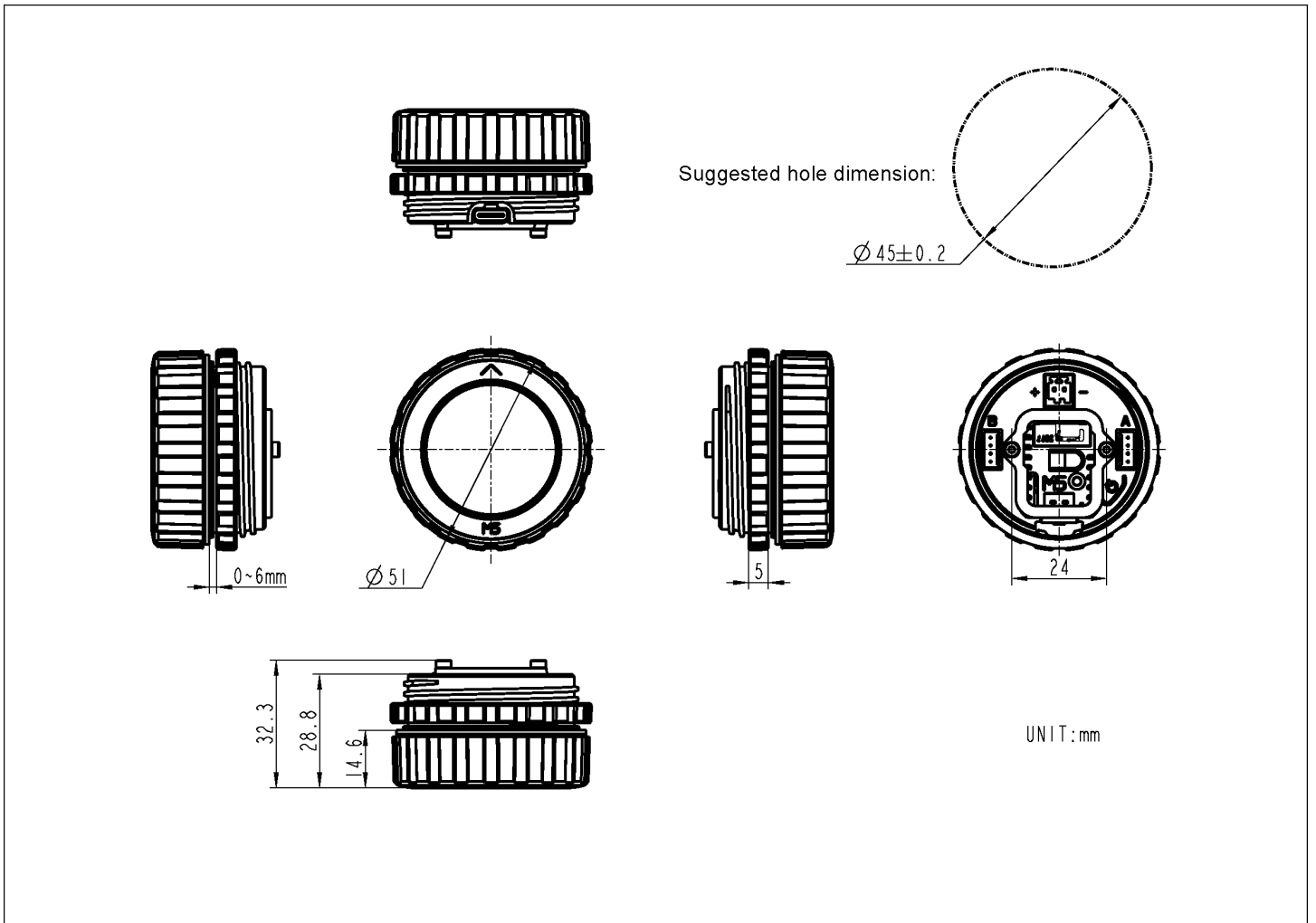

Structure

- [Dial v1.1 Structure Files](#)

Datasheets

- [BM8563](#)
- [WS1850S](#)
- [DC Power Terminal Specifications](#)
- [Lithium Battery Connector](#)

Softwares

Arduino

- [Dial v1.1 Arduino Quick Start](#)
- [Dial v1.1 Arduino Driver Library](#)

UiFlow2

- [Dial v1.1 UiFlow2 Quick Start](#)

Easyloader

Easyloader	Download Link	Notes
Dial v1.1 User Demo Easyloader	download	/
Dial v1.1 Knob Panel Demo Easyloader	download	/

ESP-IDF

- Espressif's Board Support Packages - M5Dial
- Dial v1.1 User Demo
- Dial v1.1 Knob Panel Demo

Video

- Dial v1.1 Introduction Video

0906 M5产品介绍片.m4v

- Dial v1.1 Product Introduction and Case Showcase

M5 DIAL 视频.mp4

Product Comparison

Comparison Item



Dial v1.1



Dial

Core Module	Stamp-S3A	StampS3
Antenna Design	Optimized design, stronger signal	Standard design
Stamp-S3A module Boot button	Optimized button feel, buttons use 4.0 x 3.0 x 2.0mm specs	Button specs 2.6 x 1.6 x 0.55mm
Power Consumption	Optimized for lower power consumption	Standard design