

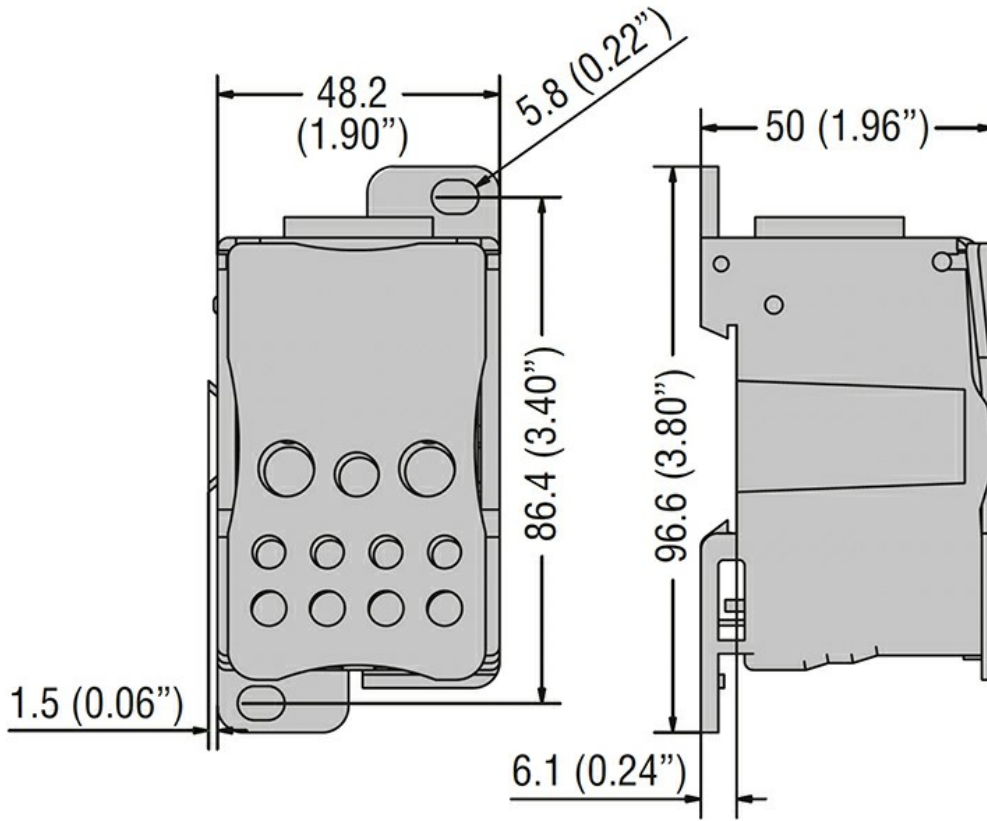

Product designation	Power distribution block	
Electrical features		
Number of poles		1
Rated insulation voltage U_i	V	1000
IEC Conventional free air thermal current $I_{th} \leq 40^\circ\text{C}$	A	520
Conventional free air thermal current I_{th} UL/CSA	A	520
Rated peak withstand current I_{pk}	kA	51
Rated short time current I_{cw} 1s	kA	24.5
Short circuit rating (UL)	kA	10
Connections		
Terminal hole diameter_Option 1	mm	Slot 25x9.5mm
Conductor section connectable_Option 1	mm ²	flexible busbar 25x9.5mm
Tightening torque Max_Option 1	Nm lbin	10 89
Terminal hole diameter_Option 2	mm	2x9.5mm
Conductor section connectable_Option 2	mm ² AWG	6...35 14..1
Tightening torque Max_Option 2	Nm lbin	4.4 39
Terminal hole diameter_Option 3	mm	5x7.5mm
Conductor section connectable_Option 3	mm ² AWG	2.5...16 14...4
Tightening torque Max_Option 3	Nm lbin	2.7 24
Terminal hole diameter_Option 4	mm	4x6mm
Conductor section connectable_Option 4	mm ² AWG	2.5...10 14...6
Tightening torque Max_Option 4	Nm lbin	2.7 24
Mechanical features		
Operating position	normal allowable	Vertical plane Any
Fixing		Screw / DIN rail 35mm

Metric Allen Key	mm	3-4-5
Weight	g	393
Resistance & Protection		
Terminals IP degree		IP20 front
Dimensions		



Certifications and compliance	
Certifications	IEC/EN/BS 60947-7-1
Compliance	cURus

ETIM classification	
EC000066 - Power contactor, AC switching	