

Description

The 3120-N...-...T1-... thermal circuit breaker/switch combination unites overcurrent protection and the function of an ON/OFF switch within a single component. The trip element is a thermobimetal. Type 3120-N...-...T1-... is ideally suited for overload protection of motors, pumps, transformers and cables. After tripping, it can reliably, easily and quickly be reset. The positively trip-free mechanism ensures reliable disconnection of the circuit even with the actuator blocked.

The 3120-N type is also available with thermal-magnetic trip. (technical data p. 21 ff.)

Type 3120-N is also available as a switch in accordance EN IEC 61058 (see data sheet switch 3120-N...Q1).

Typical applications

Medical and laboratory equipment, apparatus and machine construction, professional tools, household and garden appliances, offices machines, audio equipment, machine tools

Features

- Single or double pole thermal circuit breaker/switch combination
- Voltage ratings: AC 240 V, DC 50 V (AC 415 V upon request)
- Current rating range: 0.1 ... 20 A (up to 30 A upon request)
- Optional: push-in terminals for easy and quick wiring with a long-term stability
- Expandable functionality through appliance inlet module
- Functional extension options with add-on modules for low voltage release, auxiliary contact function, remote trip or fast magnetic trip
- Suitable for use in medical equipment according to IEC/EN 60601

Approval logos



Conformity



Your benefits

- Maximum equipment availability is ensured by overload protection perfectly matched with the loads (prevention of nuisance tripping) and quick resettability
- Reduced mounting and wiring time
- Space saving design
- Reduced disposition and storage costs
- Increased overall reliability

Further information

The current data sheet as well as other relevant documents are available on our website: www.e-t-a.de/e016

Technical data

For detailed technical information please see www.e-t-a.de/ti_e

| | |
|----------------------|--|
| Rated voltage | AC 240 V, DC 50 V (AC 415 V upon request) |
| Current rating range | 0.1 ... 20 A (up to 30A upon request for 1-pole devices only) |

Typical life 1-pole (EN 60934)

| | | |
|-----------|--------------|---|
| AC 240 V: | 0.1 ... 20 A | 30,000 cycles at 1 x I _N , inductive |
| DC 50 V: | 0.1 ... 4 A | 30,000 cycles at 1 x I _N , inductive |
| | 4.5 ... 16 A | 30,000 cycles at 1 x I _N , resistive |
| DC 28 V: | 0.1 ... 20 A | 30,000 cycles at 1 x I _N , inductive |

Typical life 2-pole (EN 60934)

| | | |
|-----------|--------------|---|
| AC 240 V: | 0.1 ... 16 A | 50,000 cycles at 1 x I _N , inductive |
| | 17 ... 20 A | 30,000 cycles at 1 x I _N , inductive |
| DC 50 V: | 0.1 ... 16 A | 50,000 cycles at 1 x I _N , inductive |
| | 17 ... 20 A | 10,000 cycles at 1 x I _N , inductive |

| | |
|---------------------|---------------|
| Ambient temperature | -30 ... 60 °C |
|---------------------|---------------|

| | |
|-------------------------------------|--|
| Insulation coordination (IEC 60664) | 2.5 kV / 2 reinforced insulation at operating area |
|-------------------------------------|--|

Dielectric strength

| | |
|--------------------------------------|--|
| Operating area pole to pole (2-pole) | Test voltage AC 3,000 V Test voltage AC 1,500 V |
|--------------------------------------|--|

| | |
|-----------------------|---------------------|
| Insulation resistance | > 100 MΩ (DC 500 V) |
|-----------------------|---------------------|

Rupture capacity I_{cn} (IEC/EN 60934)

| | I _N | U _N | I _{cn} |
|----------------|----------------|--------------------|---------------------|
| 1-pole, 2-pole | 0.1 ... 2 A | AC 240 V / DC 50 V | 10 x I _N |
| 1-pole | 2.5 ... 10 A | DC 50 V | 50 A |
| 1-pole | 2.5 ... 20 A | AC 240 V / DC 28 V | 200 A |
| 2-pole | 2.5 ... 20 A | DC 50 V | 250 A |
| 2-pole | 2.5 ... 20 A | AC 240 V / DC 28 V | 300 A |

Interrupting capacity I_{nc} (UL 1077)

| | I _N | U _N | I _{nc} |
|----------------|----------------|----------------|-----------------|
| 1-pole, 2-pole | 0.1 ... 20 A | AC 250 V | 5,000 A, C, 1 |
| 1-pole, 2-pole | 0.1 ... 20 A | DC 50 V | 1,000 A, C, 1 |

Degree of protection (IEC 60529)

| | |
|----------------|------|
| Operating area | IP40 |
| Terminal area | IP00 |

Other degrees of protection possible, depending on selected variant, see further details in data sheet.

| | |
|-----------|---|
| Vibration | 8 g (57-500 Hz), ± 0.61 mm (10-57 Hz) Test to IEC 60068-2-6, Test Fc 10 frequency cycles/axis |
|-----------|---|

| | |
|-------|---|
| Shock | 30 g (11 ms) Test to IEC 60068-2-27, Test Ea |
|-------|---|

| | |
|-----------|---|
| Corrosion | 96 hours at 5 % salt mist, Test to IEC 60068-2-11, Test Ka |
|-----------|---|

| | |
|----------|---|
| Humidity | 240 hours in 95 % RH Test to IEC 60068-2-78, Test Cab |
|----------|---|

| | |
|------|---|
| Mass | approx. 27 g (1-pole) approx. 31 g (2-pole) approx. 42 g (2-pole with PT terminals) |
|------|---|

Current ratings and internal resistance values

| Current rating (A) | Internal resistance per pole (Ω) | Current rating (A) | Internal resistance per pole (Ω) |
|--------------------|----------------------------------|--------------------|----------------------------------|
| 0.1 | 94 | 4 | 0.0435 |
| 0.2 | 24 | 4.5 | 0.0435 |
| 0.3 | 12 | 5 | 0.0325 |
| 0.4 | 5.30 | 6 | 0.0215 |
| 0.5 | 4.20 | 7 | 0.0165 |
| 0.6 | 2.90 | 8 | 0.0165 |
| 0.8 | 1.50 | 10 | < 0.02 |
| 1 | 0.9 | 12 | < 0.02 |
| 1.2 | 0.80 | 14 | < 0.02 |
| 1.5 | 0.45 | 15 | < 0.02 |
| 2 | 0.27 | 16 | < 0.02 |
| 2.5 | 0.0785 | 18 | < 0.02 |
| 3 | 0.0595 | 20 | < 0.02 |
| 3.5 | 0.0565 | | |

1



Ordering information

| | |
|--|---|
| Type no. | 3120 |
| Thermal rocker-actuated circuit breaker/switch combination | |
| Mounting method | |
| N3 | Snap-in, mounting cut-out 50.5 x 21.5 mm |
| N5 | Snap-in, mounting cut-out 44.5 x 22 mm |
| Number of poles | |
| 1 | 1-pole switching, 1-pole thermally protected |
| 2 | 2-pole switching, 2-pole thermally protected |
| 5 | 2-pole switching, 1-pole thermally protected |
| Style | |
| 1 | Standard |
| 3 | With actuator guard |
| 4 | With accordion-style seal, IP65 |
| 6 | Version with shorter flange (only for mounting method N5) |
| 7 | With water splash cover (IP54 in the actuation area) and shorter flange |
| A | With actuator guard and cross-hole (for optional interlock) |
| Terminal design | |
| PT | Push-in terminals |
| P7 | Blade terminals |
| H7 | As P7, terminals 11 and 21 with flat head screws M3.5 - standard for devices with undervoltage release module |
| N7 | As P7, with additional shunt terminals 12(i) and 22(i) |
| G7 | As N7, terminals 11 and 21 with additional flat head screws M3.5 |
| Trip curve | |
| T1 | Thermal trip |
| Actuator | |
| W | Rocker |
| Rocker colour and illumination | |
| Opaque | |
| 01 . | Black without illumination |
| 02 . | White without illumination |
| 04 . | Red without illumination |
| Translucent (when named with Y/R/T/G the rocker is illuminated) | |
| 12 . (Y) | White without illumination (illuminated) |
| 14 . (R) | Red without illumination (illuminated) |
| 15 . (Y) | Orange without illumination (illuminated) |
| 16 . (T) | Blue without illumination (illuminated) |
| 19 . (G) | Green without illumination (illuminated) |
| Marking of rocker | |
| A (not for style 4) | |
| D | |
| F | |
| K | |
| L | |
| X | |

| | |
|--|---|
| 3120-N5 2 4 - PT T1-W 19 D G ... | Ordering example |
| Illumination voltage (= operating voltage) | |
| 1 | DC 12 V |
| 2 | DC 24 V |
| 3 | AC 115 V |
| 4 | AC 230 V |
| 5 | DC 48 V |
| 6 | AC 400 V (for 2-pole versions up to 16 A) |
| Current rating | |
| 0.1 ... 20 A | |
| Terminal shroud (optional) | |
| A With terminal shroud, mounted* | |
| 3120-N5 2 4 - PT T1-W 19 D G 4 - 16 A - (A) | Ordering - example |

* Optional. If -A is added to the order designation, the 3120 is supplied with the mounted terminal shroud. Only available in combination with -P7 or -N7 terminal design variants.

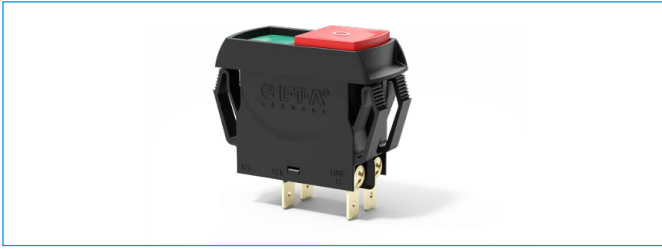

Ordering information

Ordering information

| | |
|---|---|
| Type no. | |
| 3120 Thermal circuit breaker/switch combination with push button actuation | |
| Mounting method | |
| N3 | Snap-in, mounting cut-out 50.5 x 21.5 mm |
| N5 | Snap-in, mounting cut-out 44.5 x 22 mm |
| Number of poles | |
| 1 | 1-pole switching, 1-pole thermally protected |
| 2 | 2-pole switching, 2-pole thermally protected |
| 5 | 2-pole switching, 1-pole thermally protected |
| Style | |
| D | With actuator guard |
| E | With actuator guard and water splash cover IP54 |
| F | With power-on protection |
| V | With power-on protection and water splash cover IP54 |
| Terminal design | |
| PT | Push-in terminals |
| P7 | Blade terminals |
| H7 | As P7, terminals 11 and 21 with flat head screws M3.5 - standard for units with undervoltage release module |
| N7 | As P7, with additional shunt terminals 12(i) and 22(i) |
| G7 | As N7, terminals 11 and 21 with additional flat head screws M3.5 |
| Trip curve | |
| T1 | Thermal trip |
| Actuator | |
| S | Two push buttons |
| Colour of push button/illumination (Style D and F without water splash protection) | |
| GRD | Green/red without illumination |
| GRDG | Green with LED illumination/red without illumination |
| Colour of push button/illumination (Style E and V with water splash protection) | |
| GRX | Green/red without illumination |
| GRXG | Green with LED illumination/red without illumination |
| Illumination voltage range (= operating voltage) | |
| 1 | DC 12 V |
| 2 | DC 24 V |
| 3 | AC 115 V |
| 4 | AC 230 V |
| 5 | DC 48 V |
| 6 | AC 400 V (for 2-pole versions up to 16 A) |
| Current rating | |
| 0.1 ... 20 A | |
| Terminal shroud (optional) | |
| A | With terminal shroud, mounted* |
| 3120-N3 5 V - PT T1-S GRD - 20 A - (A) Ordering - example | |

| | |
|---|---|
| Type no. | |
| 3120 Thermal resettable circuit breaker with push button | |
| Mounting method | |
| N3 | Snap-in, mounting cut-out 50.5 x 21.5 mm |
| N5 | Snap-in, mounting cut-out 44.5 x 22 mm |
| Number of poles | |
| 1 | 1-pole thermally protected |
| 2 | 2-pole thermally protected |
| 5 | 2-pole, 1-pole thermally protected |
| Style | |
| G | Resettable circuit breaker |
| Terminal design | |
| PT | Push-in terminals |
| P7 | Blade terminals |
| H7 | As P7, terminals 11 and 21 with flat head screws M3.5 - standard for units with undervoltage release module |
| N7 | As P7, with additional shunt terminals 12(i) and 22(i) |
| G7 | As N7, terminals 11 and 21 with additional flat head screws M3.5 |
| Trip curve | |
| T1 | Thermal trip |
| Actuator | |
| D | One push button |
| Colour of push button | |
| 01 | Black |
| 02 | White opaque |
| 04 | Red opaque (UL/CSA approval only) |
| 09 | Green opaque |
| Marking of the push button | |
| X | Without marking |
| Current rating | |
| 0.1 ... 20 A | |
| Terminal shroud (optional) | |
| A | With terminal shroud, mounted* |
| 3120-N3 2 G - PT T1 - D 01 - X 20 A - (A) Ordering - example | |

Please observe our minimum ordering quantities.

* Optional. If -A is added to the order designation, the 3120 is supplied with the mounted terminal shroud. Only available in combination with -P7 or -N7 terminal design variants.

Customer-specific solutions

Looking for a version you cannot find in our order numbering code? Please get in touch.

Approvals

| Approval authority | Standard | Rated voltage | Current rating range | Appr.-marks |
|--------------------|--------------|---|--|-------------|
| VDE | IEC/EN 60934 | AC 240 V DC 50 V DC 50 V DC 28 V | 0.1 A ... 20 A 0.1 ... 20 A (2-pole) 0.1 ... 16 A (1-pole) 0.1 A ... 20 A | |
| UL | UL 1077 | AC 250 V AC 250 V DC 50 V AC 250 V | 0.1 A ... 16 A (TC1, OL1) 17 A ... 20 A (TC1, OL0) 0.1 A ... 20 A (TC1, OL0) 30 A* (TC1, OL0) | |
| CSA | C22.2 No 235 | AC 250 V AC 250 V DC 50 V AC 250 V | 0.1 A ... 16 A (TC1, OL1) 17 A ... 20 A (TC1, OL0) 0.1 A ... 20 A (TC1, OL0) 30 A* (TC1, OL0) | |
| CQC | GB 17701 | AC 240 V DC 50 V | 0.1 A ... 20 A 0.1 A ... 20 A | |
| KTL | KC60934 | AC 240 V | 0.1 ... 20 A (2-pole) | |

* 2 poles in parallel

Mounting method

Mounting method

mounting cut-out -N3

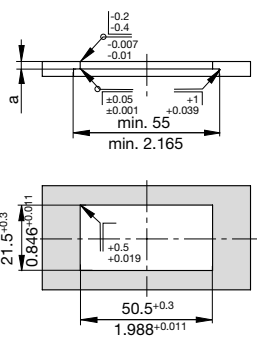

mounting cut-out -N5

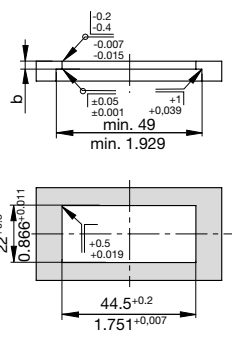

| Panel thickness | Style variants 1/3/6/7/A/D/F/G | Style variants 4, E and V |
|-----------------|--------------------------------|---------------------------|
| a | 1 - 6.35 mm | 1 - 5.5 mm |
| b | 1 - 4 mm | 1 - 3.2 mm |

Schematic diagrams

2-pole switching and 2-pole thermally protected

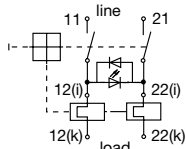

2-pole switching and 1-pole thermally protected

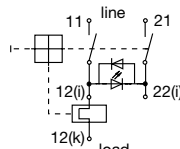

1-pole switching and 1-pole thermally protected

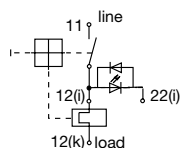

Time/current characteristics

0.1...2 A

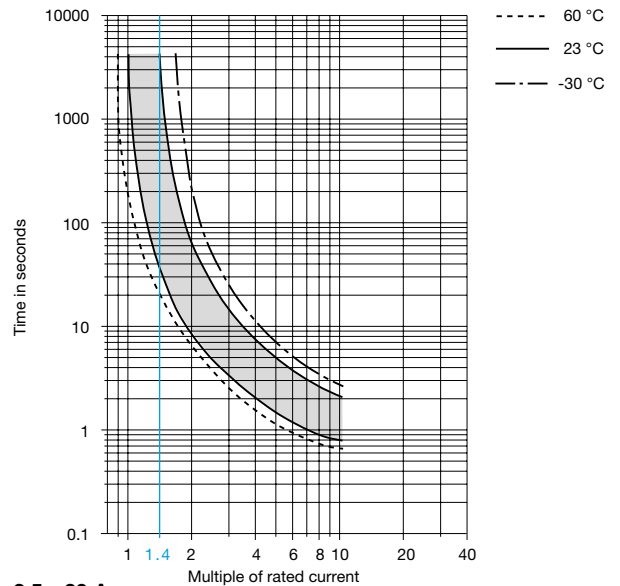

2.5...20 A

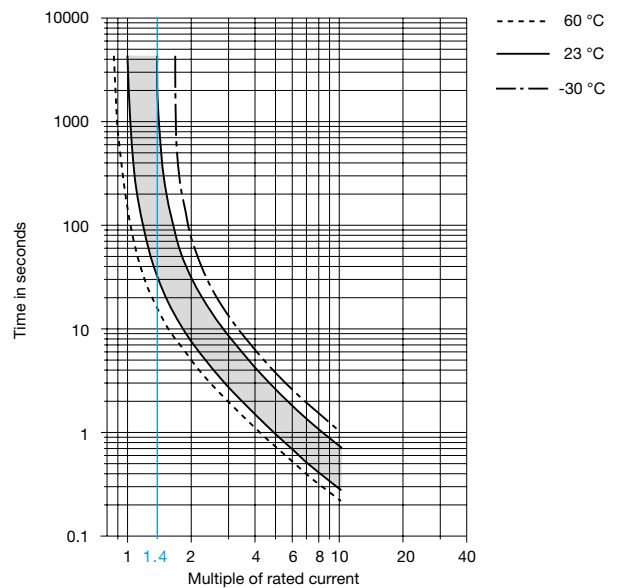

The time/current characteristic depends on the ambient temperature. In order to eliminate nuisance or late tripping, please multiply the current rating of the circuit breaker by a temperature factor (see chapter Technical Information) For detailed technical information please see www.e-t-a.de/ti_e

| Ambient temperature [°C] | -30 | -20 | -10 | 0 | 23 | 40 | 50 | 60 |
|--------------------------|-----|------|------|------|----|------|------|------|
| Temperature factor | 0.8 | 0.84 | 0.88 | 0.92 | 1 | 1.08 | 1.14 | 1.23 |

Dimensions

3120-N3.1-H7...

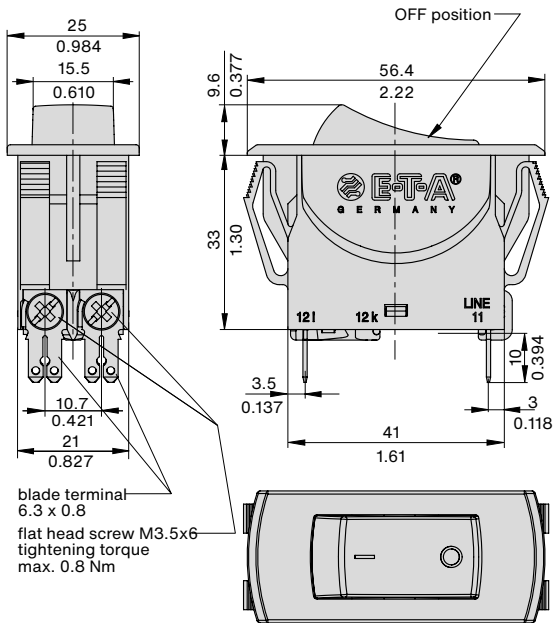

3120-N5.1-P7...

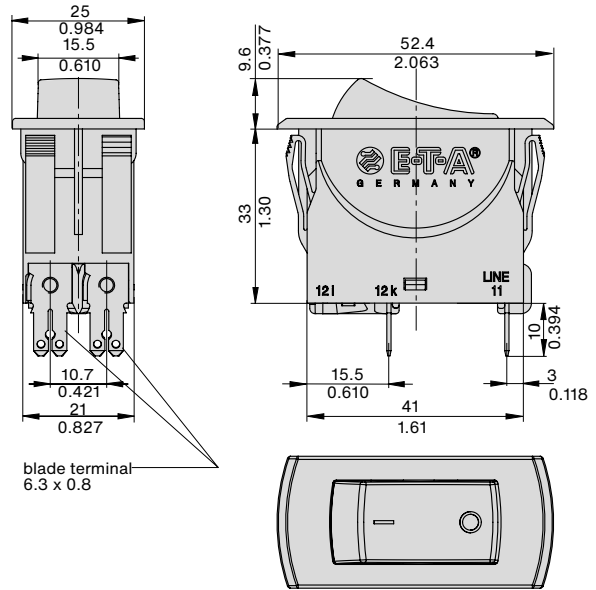

3120-N5.6-P7...

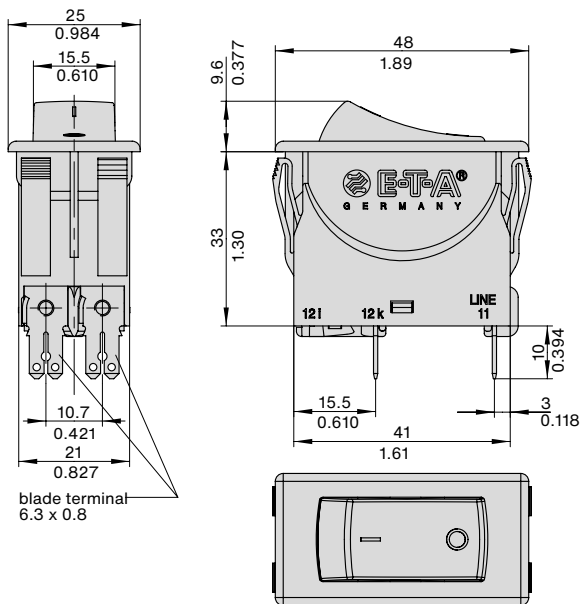

3120-N5.7-P7...

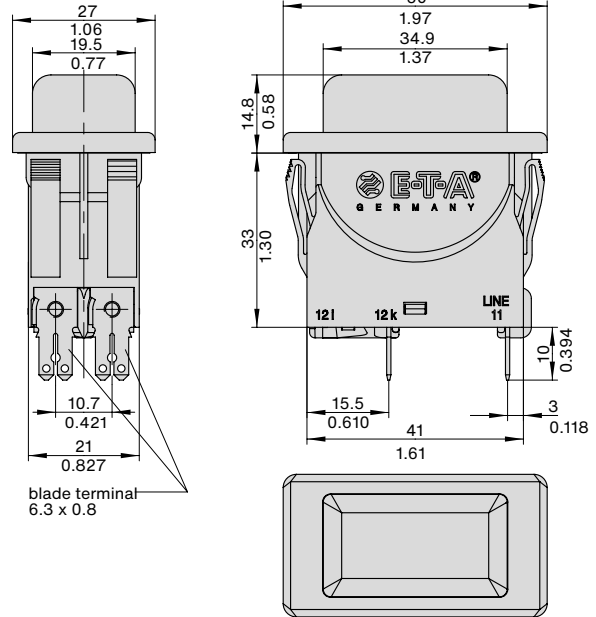

Dimensions

3120-N5.1-PT...

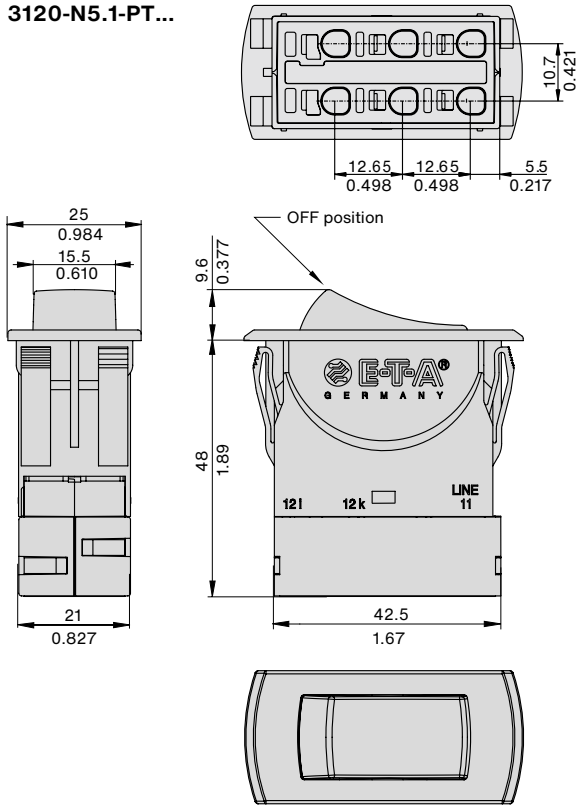

3120-N5.3-P7...

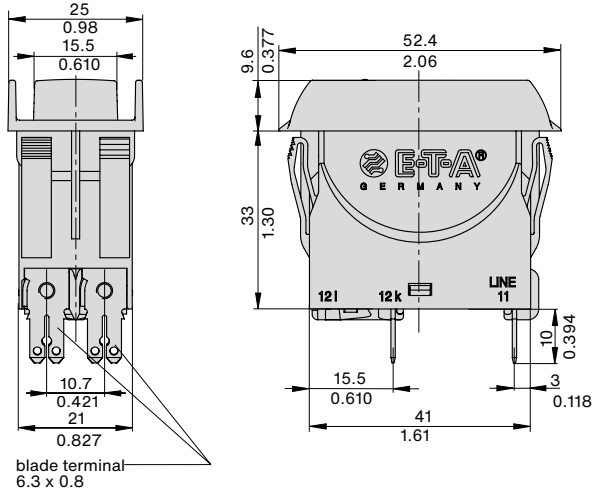

3120-N5.4-P7...

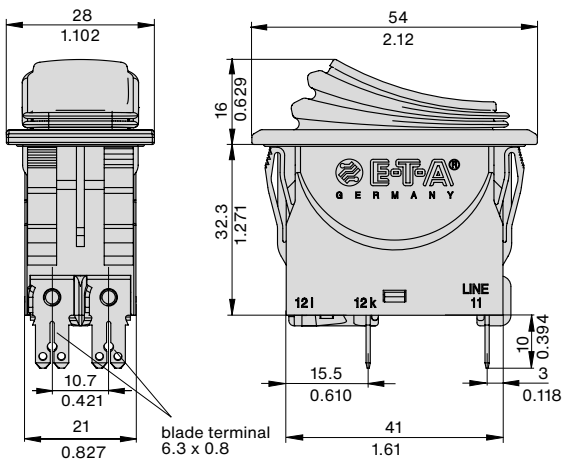

3120-N5.A-P7...

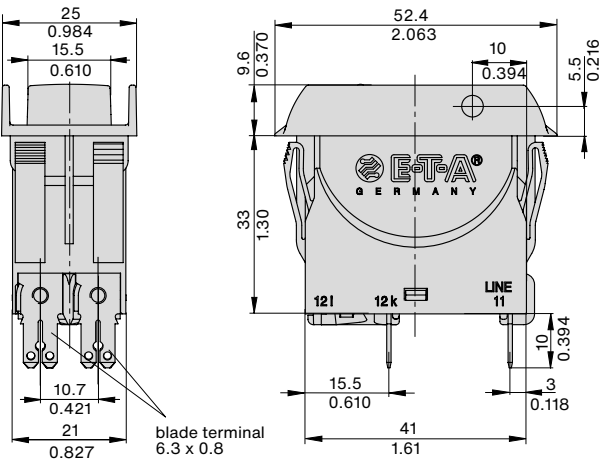

1

Dimensions

3120-N3.D-P7...

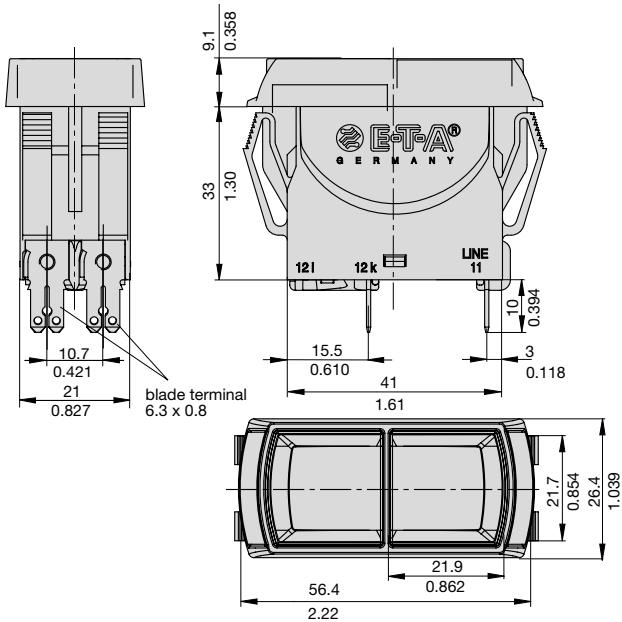

3120-N5.D-P7...

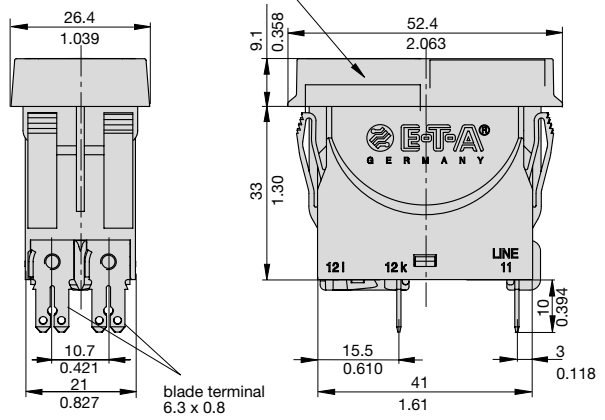

3120-N5.E-P7...

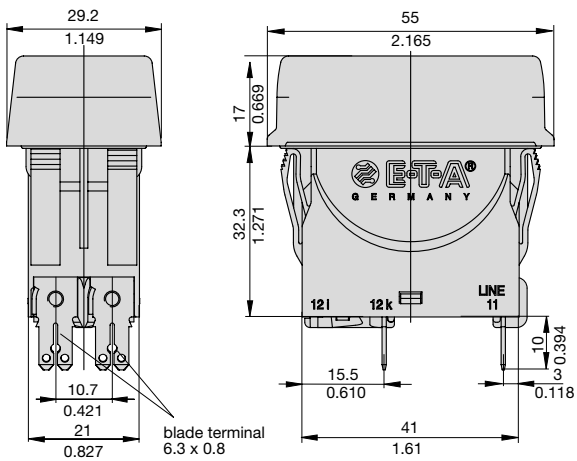

3120-N5.F-P7...

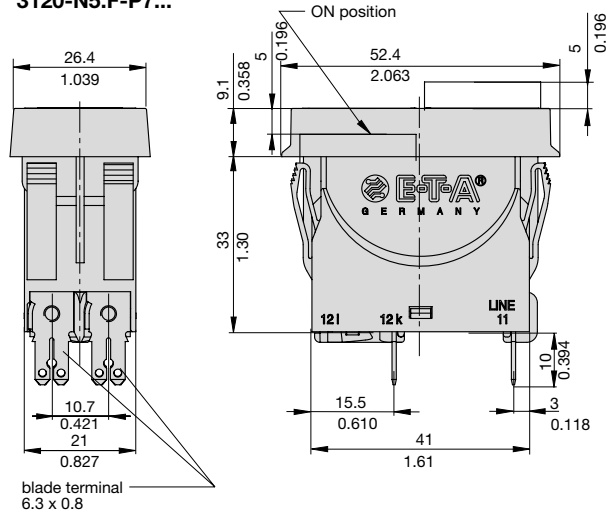

3120-N5.V-P7...

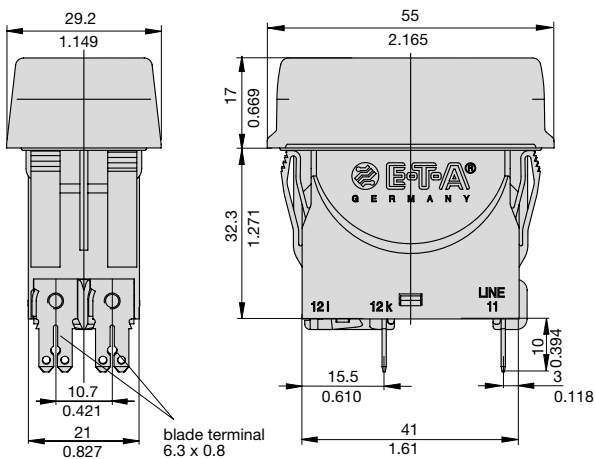

Dimensions

3120-N3.G-P7...

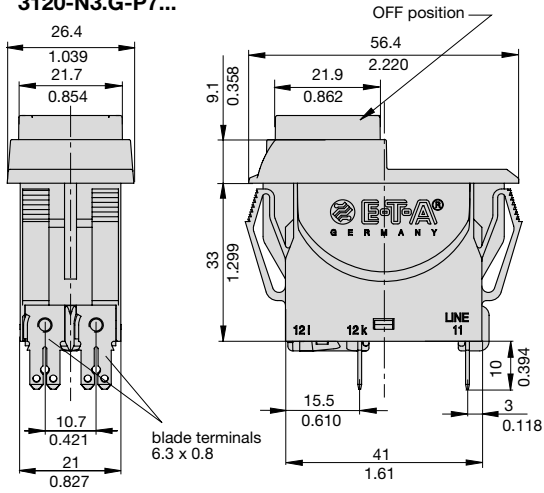

3120-N5.G-P7...

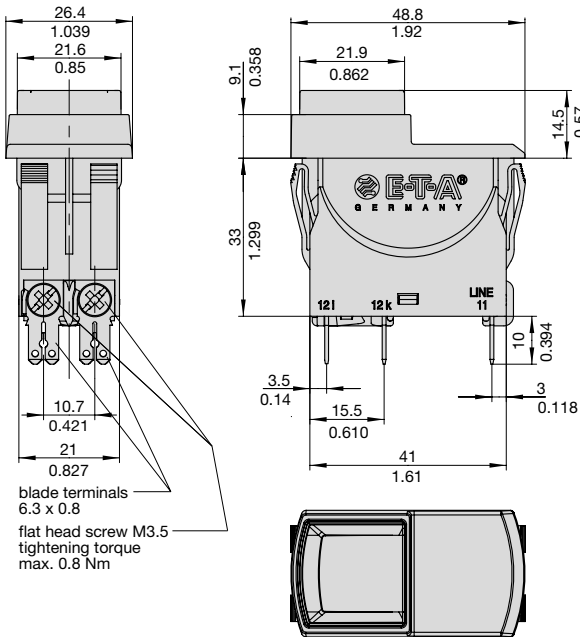

Cable cross sections PT terminals

| Cable | Cross section with direct push-in wiring |
|---|--|
| rigid | 1...4 mm ² (stripping length: 10 mm) |
| flexible with wire end ferrule (with or without plastic sleeve) | 0.5...2.5 mm ² , length of metal sleeve 8 - 12 mm |
| Cable | Cross section when opening the push-in terminals |
| rigid | 0.5...4 mm ² (stripping length: 10 mm) |
| flexible without wire end ferrule | 0.5...2.5 mm ² |
| flexible with wire end ferrule (with or without plastic sleeve) | 0.5...2.5 mm ² , length of metal sleeve 8 - 12 mm |

Installation drawing

3120 with blade terminals

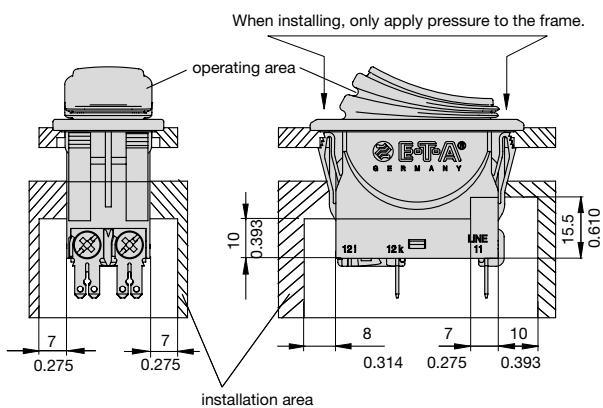

3120 with push-in terminals

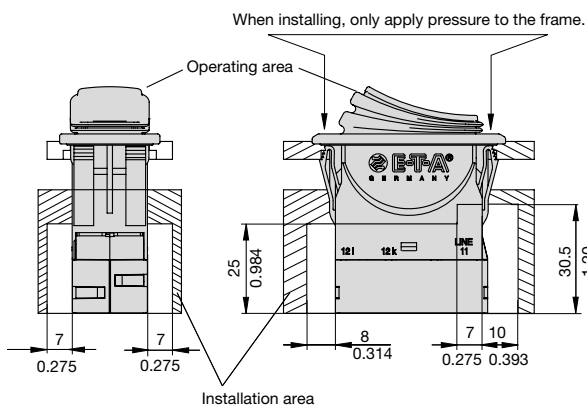

Terminal types

2-pole switching and 2-pole thermally protected

3120-N524-PT

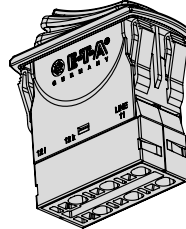

2-pole switching and 1-pole thermally protected

3120-N554-PT



3120-N524-P7

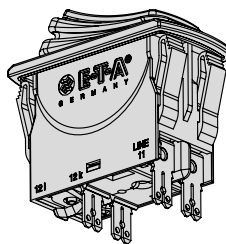

3120-N554-P7

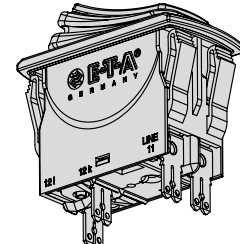

3120-N524-H7

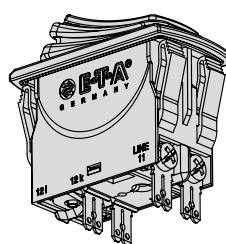

3120-N554-H7

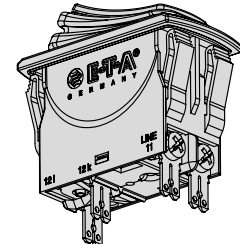

3120-N524-N7

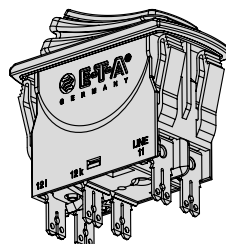

3120-N554-N7

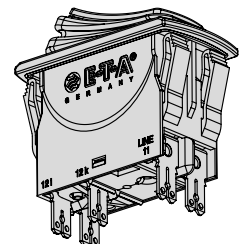

3120-N524-G7

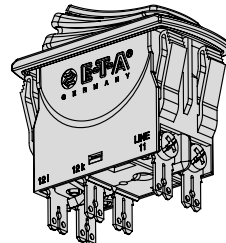

3120-N554-G7

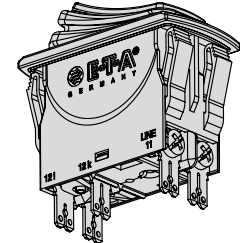

Terminal shroud

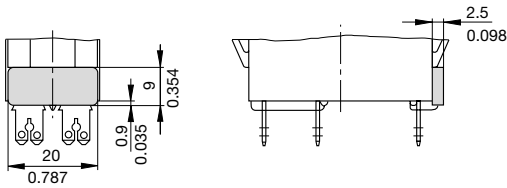

Optionally available in combination with -P7 or -N7 terminal design variants. For details, see ordering information.

Accessories

Terminal adapter order no. Y 303 862 01

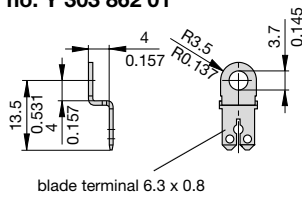

blade terminal 6.3 x 0.8

Cover for -N3 mounting cut-out order no. Y 303 885 31

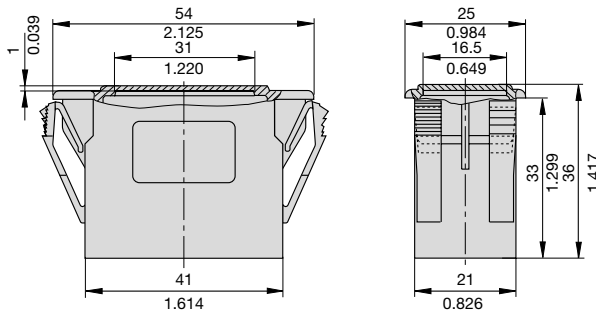

Cover for terminal area (IP20) order no. Y 304 275 01

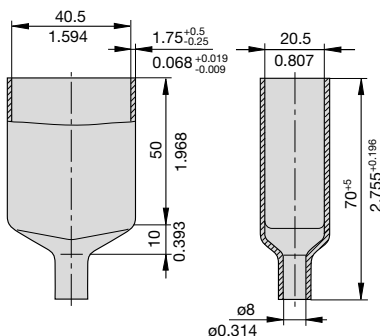

All information and data given on our products are accurate and reliable to the best of our knowledge, but E-T-A does not accept any responsibility for the use in applications which are not in accordance with the present specification. E-T-A reserves the right to change specifications at any time in the interest of improved design and performance. Dimensions are subject to change without notice. Please enquire for the latest dimensional drawing with tolerances if required. All dimensions, data, pictures and descriptions are for information only and are not binding. Amendments, errors and omissions excepted. Part numbers of the devices may differ from their marking.

Note: Terminal drawings

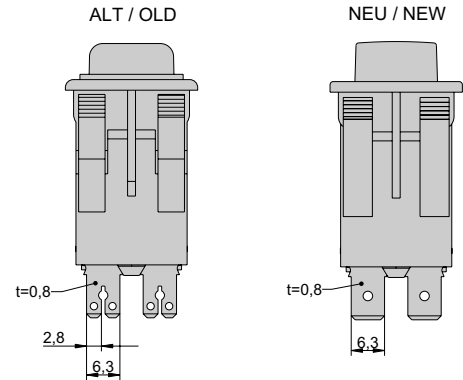

Note: The flat terminals are changed from slotted to unslotted from June 2026 onwards. This will not affect their shape, fit or function (the electromechanical specifications will remain the same). The order number remains the same as well. However, it will no longer be possible to attach receptacles for 2.8 x 0.8 mm. In some illustrations in this data sheet, the old version of the flat plug is still visible.

Accessories

Snap-in frame for 3120-N3... order no. Y 303 675 01/02

Snap-in frame for 3120-N5... order no. Y 303 676 01

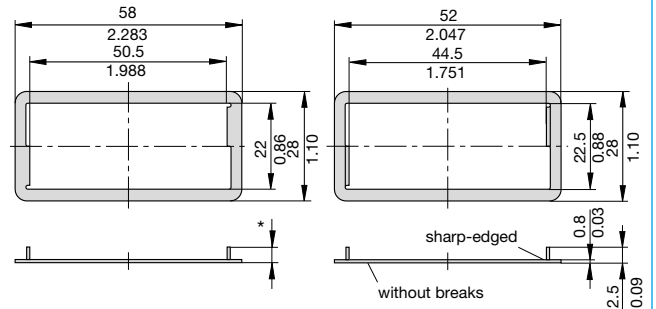

* Y 303 675 01 can only be used for mounting panel thickness < 2 mm
* Y 303 675 02 can only be used for mounting panel thickness < 4 mm

The snap-in frame is used in special cases to ensure a tight fit of the circuit breaker in the mounting cut-out, e.g. in case of dimensional tolerances, soft materials or if the specified edge condition cannot be maintained.

Snap-in frame mounting

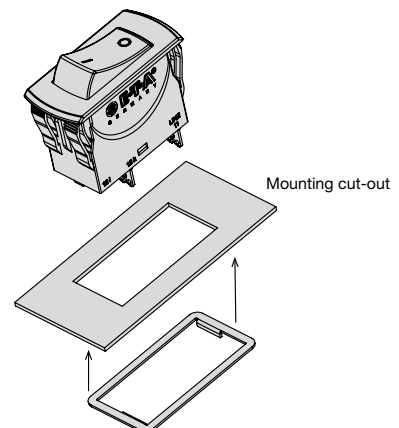

Accessories

Connection adapter

Order number Y 31214001

For pre-assembly of the connection cables. Two snap-in hooks ensure a firm plug-in connection.

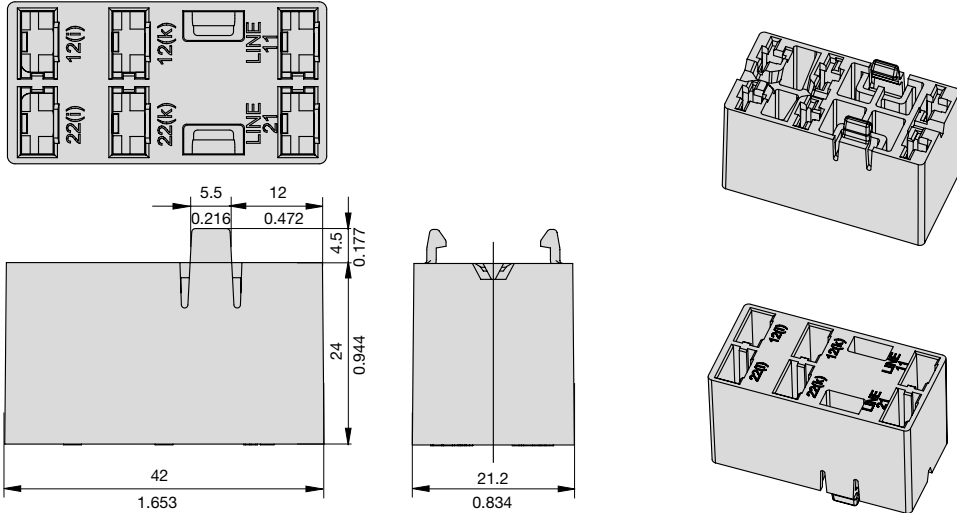

Benefits:

- Time and cost savings during final assembly
- Quick replacement of devices
- Cover for the blade terminals (IP20)

Note:

Supplied without female contacts.

The chamber dimensions for the female contacts (plug width 6.3 mm) are in accordance with DIN 46340 Part 3, Form A.

Examples of suitable receptacles: Stocko RSB 7916 F6.3-1. Klauke type 2730. Vogt type 3832d.67.

TE FASTON Terminals 250 Series. Delphi Packard 58 Series;

Connection adapter plugged onto circuit breaker:

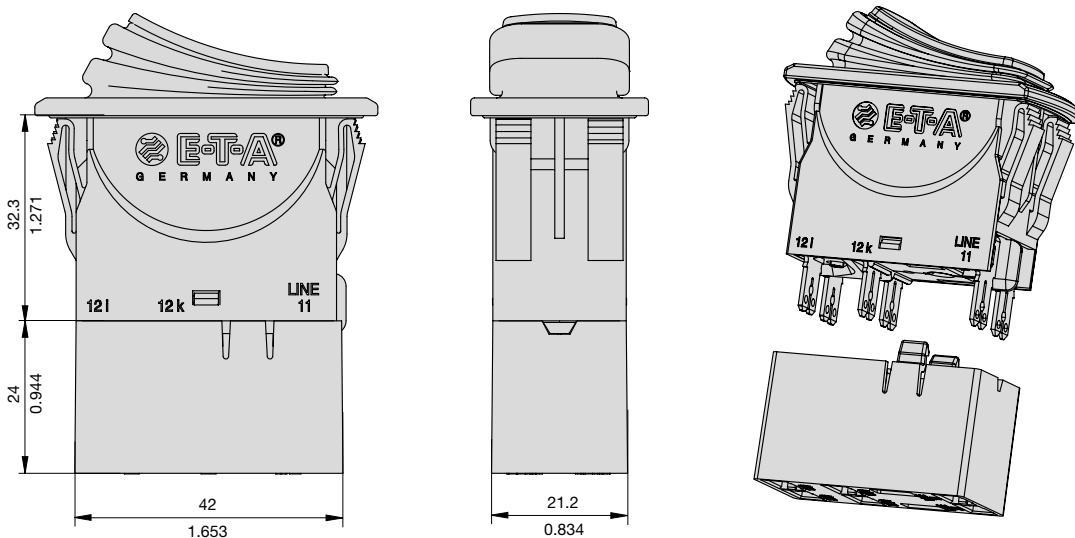

Description – appliance inlet module X3120 A/B

The X3120 appliance inlet module with 3120- N5 circuit breaker combines up to four functions within a single component: A C14/C20 appliance inlet, an ON/ OFF switch, resettable overcurrent protection and a line filter. Screw-type mounting from the front or from the rear.

Typical applications

Electrical medical apparatus, laboratory equipment, professional audio equipment and office machines.

Approvals

X3120-A – C14 inlet plugs

| Approval authority | Standard | Rated voltage | Max. current rating |
|----------------------|-----------------------------------|---------------|---------------------|
| ENEC | IEC/EN 60320-1 | AC 240 V | 10 A |
| UL/CSA ¹⁾ | UL 60320-1, CSA C22.2 no. 60320-1 | AC 250 V | 15 A |
| CQC | CCC | AC 250 V | 10 A |

¹⁾ X3120-A0400 also available with overall approval according to UL 60320-1 at max. 15 A rated current.

X3120-A - filter

Design to UL 1283, CSA 22.2 No. 8 1986, IEC/EN 60939

X3120-B – C20 inlet plugs

| Approval authority | Standard | Rated voltage | Max. current rating |
|----------------------|-----------------------------------|---------------|---------------------|
| ENEC | IEC/EN 60320-1 | AC 240 V | 16 A |
| UL/CSA ²⁾ | UL 60320-1, CSA C22.2 no. 60320-1 | AC 240 V | 20 A |

²⁾ X3120-B0400 also available with overall approval according to UL 60320-1 at max. 20 A rated current.

Please note: the current rating of the circuit breaker must not exceed the max. current of the filter/inlet plug, depending on the approval.

Selection of filter rating

| Current rating of circuit breaker | Min. rating of filter |
|-----------------------------------|-----------------------|
| 0.1 ... 1 A | 1 A |
| 1.2 ... 3 A | 3 A |
| 3.5 ... 6 A | 6 A |
| 7 ... 8 A | 8 A |
| 9 ... 10 A | 10 A |
| 12 A | 12 A |
| 14 ... 15 A | 15 A |

The current rating of the circuit breaker must not be higher than the filter current rating. For best attenuation a filter with the smallest possible current rating should be selected. Depending on the IEC/EN or UL/CSA approval, other maximum values are permissible for the inlet plug. The table above serves as orientation.

For protection of the filter in the event of higher overcurrents, we recommend 3120- N circuit breakers with thermal-magnetic trip (3120- N...-M1...).

For further technical information please refer to page 21.



Ordering information

Type no.

X3120 Appliance inlet module for circuit breaker type 3120- N

Module

A C14 appliance inlet
(can be combined with 3120-N5.6/-N5.7/-N5.G)

B C20 appliance inlet
(without filter, can be combined with 3120-N5.6/-N5.G)

Mounting method

04 Screw-type mounting

Filters

00 Without filter

01 Standard line filter

03 Standard line filter for medical equipment

06 High-power line filter for medical equipment

Current rating for filter (only with module A)

01 1 A

03 3 A

06 6 A

08 8 A

10 10 A

12 12 A

15 15 A

Version

01 Not wired, mounting position 3120:
OFF position at connector

11 Wired; mounting position 3120:
OFF position at connector

Supply status

M Module supplied with mounted
3120 circuit breaker and connector

X3120-A 04 01 08 01 M Ordering example

Note: the power entry module is only available as a ready-to-use unit including the 3120 circuit breaker, C14/C20 appliance inlet and wiring (if selected).

All information and data given on our products are accurate and reliable to the best of our knowledge, but E-T-A does not accept any responsibility for the use in applications which are not in accordance with the present specification. E-T-A reserves the right to change specifications at any time in the interest of improved design and performance. Dimensions are subject to change without notice. Please enquire for the latest dimensional drawing with tolerances if required. All dimensions, data, pictures and descriptions are for information only and are not binding. Amendments, errors and omissions excepted. Part numbers of the devices may differ from their marking.

Technical data

| | X3120-A0400 (without filter) | X3120-A040x | X3120-B0400 |
|----------------------------------|--|--|---|
| Rated voltage | AC 250 V | AC 250 V | AC 250 V |
| Current rating (appliance inlet) | 10 A (IEC/EN) 15 A (UL/CSA) | 10 A (IEC/EN) 15 A (UL/CSA) | 16 A (IEC/EN) 20 A (UL/CSA) |
| Ratings of filter | | 1 A, 3 A, 6 A, 8 A, 10 A, 12 A, 15 A | |
| Operating temperature | -25°C ... +60°C | -25°C ... +60°C | -25°C ... +60°C |
| Number of poles | L, N + mass | L, N + mass | L, N + mass |
| Degree of protection | I | I | I |
| Mounting method | Screw-type mounting (from the front or from the rear) | Screw-type mounting (from the front or from the rear) | Screw-type mounting (from the front or from the rear) |
| Terminals | DIN46244 blade terminal 6.3 mm x 0.8 mm | DIN46244 blade terminal 6.3 mm x 0.8 mm | DIN46244 blade terminal 6.3 mm x 0.8 mm |
| Housing material | Thermoplastics, black, UL94V-0 | Thermoplastics, black, UL94V-0 | Thermoplastics, black, UL94V-0 |
| Appliance inlet: | C14 to IEC/EN 60320-1, UL 60320-1, CSA C22.2 no. 60320 - 1 | C14 with line filter to IEC/EN 60939, UL 1283, CSA 22.2 no. 8 | C20 to IEC/EN 60320-1, UL 60320-1, CSA C22.2 no. 60320-1 |
| Main switch | circuit breaker for equipment protection 3120-N5.6 3120-N5.7 3120-N5.G | circuit breaker for equipment protection 3120-N5.6 3120-N5.7 3120-N5.G | circuit breaker for equipment protection 3120-N5.6 3120-N5.G |

**X3120-A0400 dimensional drawing
(in fig. with 3120-N5.6)**

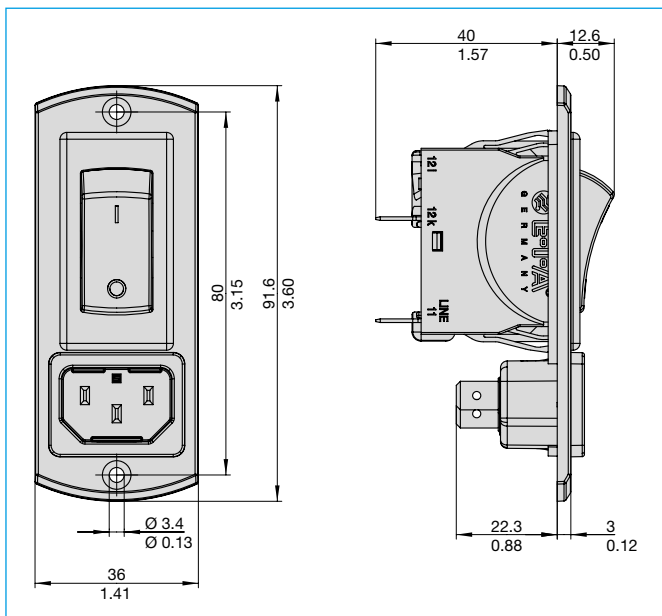

**X3120-A040x dimensional drawing
(in fig. with 3120-N5.6)**

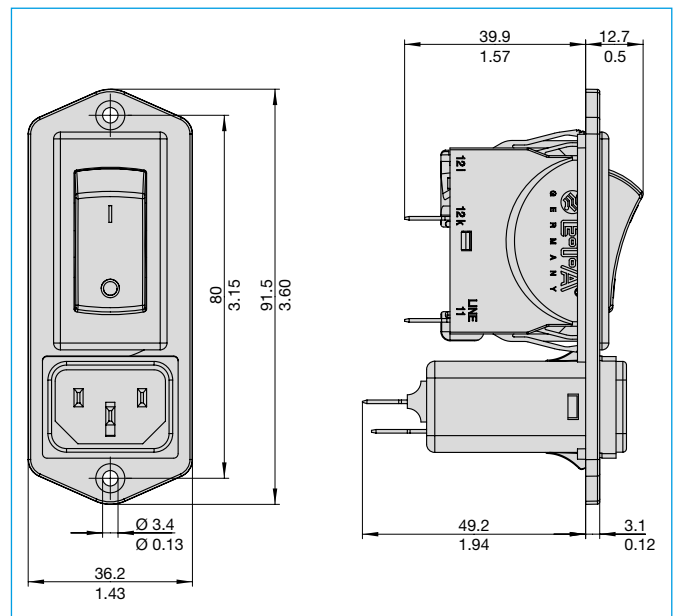

**X3120-B0400 dimensional drawing
(in fig. with 3120-N5.6)**

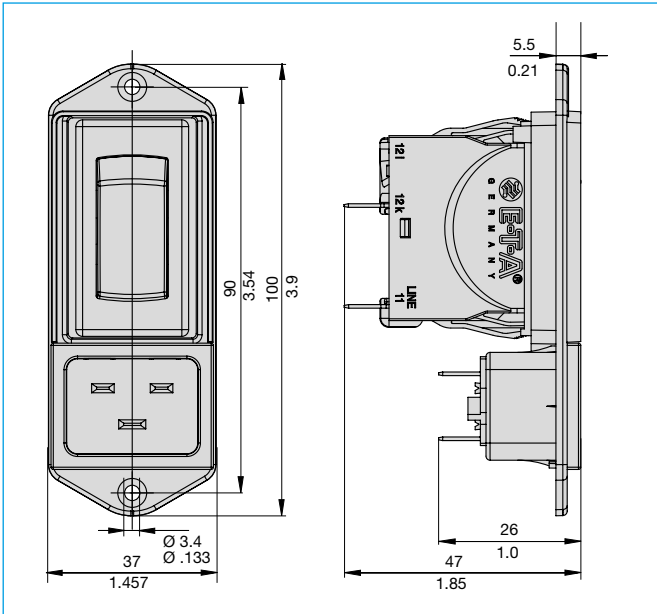

Mounting cut-out

**X3120-A0400
X3120-A040x**

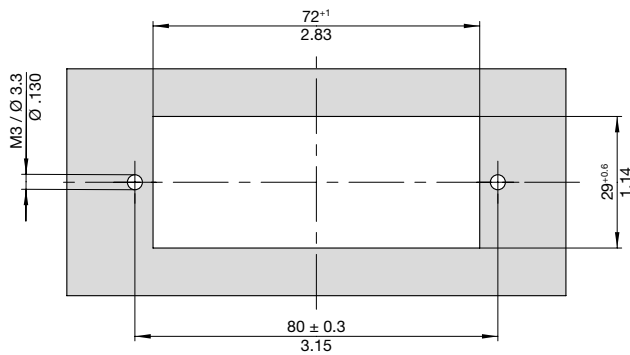

X3120-B0400

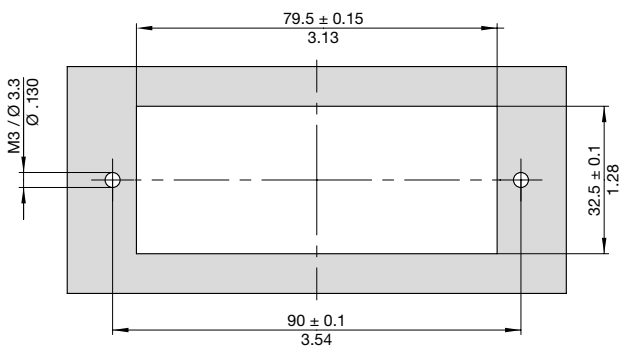

Schematic diagram X3120-A

X3120-A0401
Standard filter

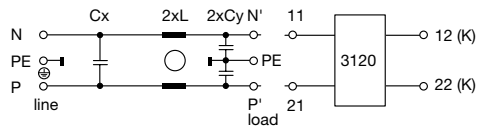

X3120-A0403 and X3120-A0406
Line filter for medical equipment

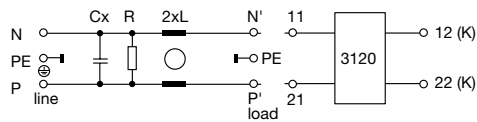

Line filter attenuation curves

X3120-A0401 standard line filter

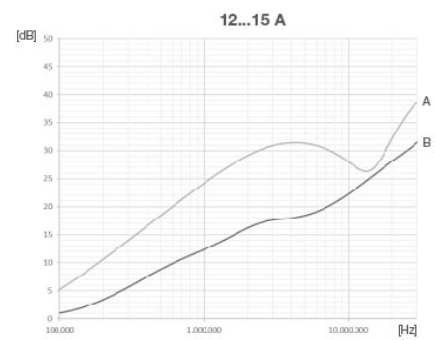
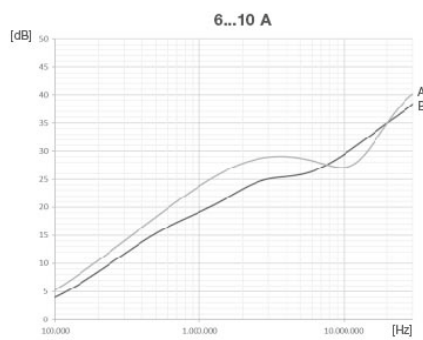
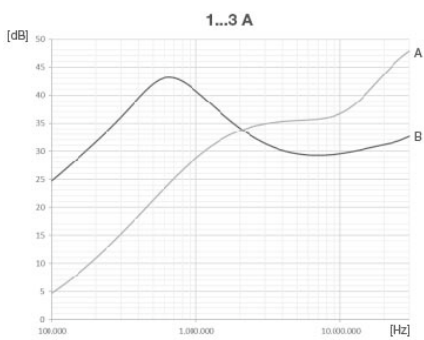

X3120-A0403 standard line filters for medical equipment

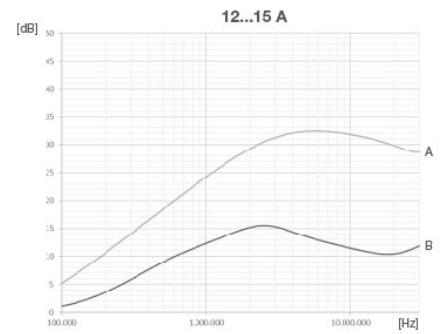
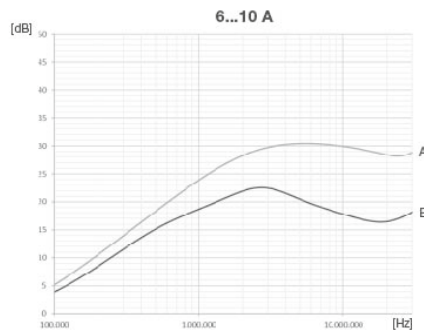
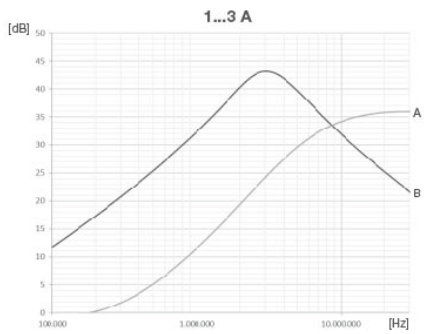

Line filter attenuation curves

X3120-A0406 high performance filters for medical equipment

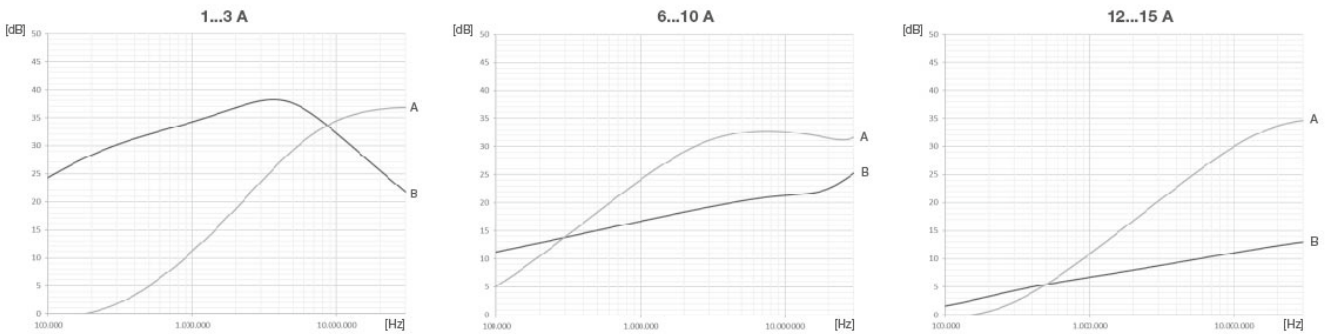

Attenuation curves diagram, information according to CISPR17
 curve A (DM, differential mode): 50/50 Ohm sym.
 curve B (CM, common mode): 50/50 Ohm asym.

Note

The attenuation curves provide an indication of the attenuation behaviour without taking the device /machine environment into account. A measurement is mandatory to verify the EMC conformity of your device/machine.

Filter selection table

| Filters | Current rating 50 °C (25 °C) A | Leakage current 250VAC/50Hz µA | Inductance L mH | Capacity Cx µF | Capacity Cy nF | Resistance R kΩ |
|------------------|--------------------------------------|---|--------------------|-------------------|-------------------|--------------------|
| X3120-A040101..M | 1 (1.2) | 373 | 12 | 0.1 | 2.2 | |
| X3120-A040103..M | 3 (3.5) | 373 | 2.5 | 0.1 | 2.2 | |
| X3120-A040106..M | 6 (7.2) | 373 | 0.78 | 0.1 | 2.2 | |
| X3120-A040108..M | 8 (10.6) | 373 | 0.5 | 0.1 | 2.2 | |
| X3120-A040110..M | 10 (11.6) | 373 | 0.225 | 0.1 | 2.2 | |
| X3120-A040112..M | 12 (12) | 373 | 0.11 | 0.1 | 2.2 | |
| X3120-A040115..M | 15 (15) | 373 | 0.075 | 0.1 | 2.2 | |
| | | | | | | |
| X3120-A040301..M | 1 (1.2) | 2 | 12 | 0.1 | | 1000 |
| X3120-A040303..M | 3 (3.5) | 2 | 2.5 | 0.1 | | 1000 |
| X3120-A040306..M | 6 (7.2) | 2 | 0.78 | 0.1 | | 1000 |
| X3120-A040308..M | 8 (10.6) | 2 | 0.5 | 0.1 | | 1000 |
| X3120-A040310..M | 10 (11.6) | 2 | 0.225 | 0.1 | | 1000 |
| X3120-A040312..M | 12 (12) | 2 | 0.11 | 0.1 | | 1000 |
| X3120-A040315..M | 15 (15) | 2 | 0.075 | 0.1 | | 1000 |
| | | | | | | |
| X3120-A040601..M | 1 (1.2) | 2 | 59.53 | 0.1 | | 1000 |
| X3120-A040603..M | 3 (3.5) | 2 | 13.45 | 0.1 | | 1000 |
| X3120-A040606..M | 6 (7.2) | 2 | 4.1 | 0.1 | | 1000 |
| X3120-A040608..M | 8 (10.6) | 2 | 2.3 | 0.1 | | 1000 |
| X3120-A040610..M | 10 (11.6) | 2 | 1.02 | 0.1 | | 1000 |
| X3120-A040612..M | 12 (12) | 2 | 0.58 | 0.1 | | 1000 |
| X3120-A040615..M | 15 (15) | 2 | 0.4 | 0.1 | | 1000 |

Description X3120-U undervoltage release module

The undervoltage release module reliably excludes personal injury through automatic re-start after voltage dip or power failure.

Note: 3120- N...-H7 or -G7 basic device requires screw terminals. Not possible in combination with PT terminals.

Applies in combination with design variant 4 (accordion-style):
In the event of voltage dip or power failure, the undervoltage release module switches Circuit breaker off. The rocker actuator will go into centre position. Reset is effected in two steps:
Step 1: Switch rocker into OFF position.
Step 2: Reset circuit breaker.

Not possible with style configurations D and E.

Typical applications

All machines that could cause personal injury upon automatic re-start, e.g. drilling machines, electric saws, meat cutting machines etc.

The X3120-U02 version allows set up of a cost-effective safety circuit via the physically isolated undervoltage release module, which enables implementation for example of a remote disconnection with emergency stop.

Ordering information

| | |
|------------------------|---|
| Type no. | |
| X3120 | Module for 3120-N device |
| Module | |
| U | Undervoltage release module |
| Design | |
| 00 | Standard (without separate connections) |
| 01 | 1 blade terminals 2.8x0.8 |
| 02 | 2 blade terminals 2.8x0.8 |
| Rated voltage | |
| 00 | AC 230/240 V 50/60 Hz |
| 01 | AC 120 V 50/60 Hz |
| 02 | AC 100 V 50/60 Hz |
| 03 | DC 24 V |
| 04 | AC 400 V 50/60 Hz |
| Supply status | |
| M | Module mounted to circuit breaker 3120 |
| X3120- U 0000 M | Ordering example |

Dimensions - undervoltage release module

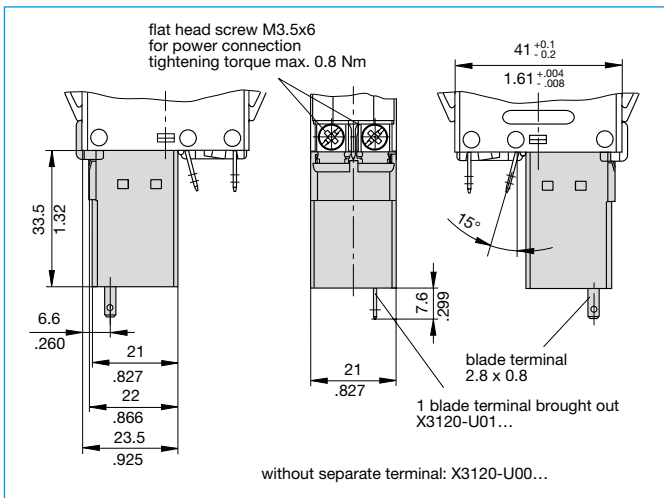

Schematic diagrams

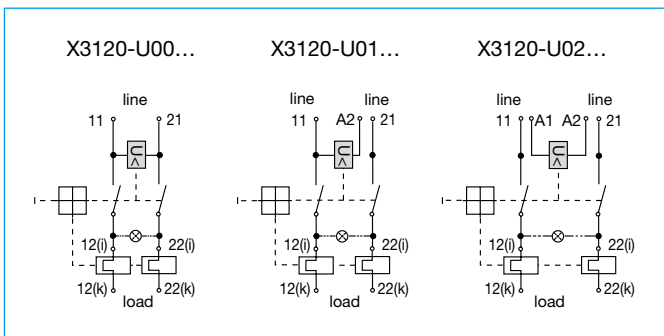

Technical data

| | |
|---------------------|---|
| Voltage ratings: | AC 100 V; AC 120 V; AC 230/240 V; AC 400 V (50/60 Hz) DC 24 V |
| Voltage tolerances | + 10 %/- 15 % |
| Typical life | 20,000 cycles |
| Current consumption | approx. 2.5 mA |
| Release values | $0.2 \times U_N < U < 0.7 \times U_N$ (at a rated voltage of AC 100 V the device can trip at 70 V and must trip at 20 V) |
| Trip time | < 20 ms |
| Latch-in values | $\geq 85 \% U_N$ |
| Ambient temperature | -30 ... 60 °C |
| Vibration | 8 g (57-500 Hz), ± 0.61 mm (10-57 Hz) Test to IEC 60068-2-6, Test Fc 10 frequency cycles/axis |
| Shock | 30 g (11 ms) Test to IEC 60068-2-27, Test Ea |
| Corrosion | 48 hours at 5 % salt mist, Test to IEC 60068-2-11, Test Ka |
| Humidity | 240 hours in 95 % RH Test to IEC 60068-2-78, Test Cab |
| Mass | approx. 56 g (including base device) |

All information and data given on our products are accurate and reliable to the best of our knowledge, but E-T-A does not accept any responsibility for the use in applications which are not in accordance with the present specification. E-T-A reserves the right to change specifications at any time in the interest of improved design and performance. Dimensions are subject to change without notice. Please enquire for the latest dimensional drawing with tolerances if required. All dimensions, data, pictures and descriptions are for information only and are not binding. Amendments, errors and omissions excepted. Part numbers of the devices may differ from their marking.

Description X3120-S auxiliary contact module

Add-on module for circuit breaker type 3120-F. The auxiliary contact module has a change-over contact as signal contact and is operated with actuation of the CBE.

Note: Only possible with terminal versions N7 and P7.

Typical applications

Status monitoring of CBE and/or the connected loads.

Ordering information

| | |
|----------------------------|--|
| Type no. | |
| X3120 | Module for 3120-N device |
| Module | |
| S | Auxiliary contact module |
| Design | |
| 0 | Change-over contact |
| Terminal design | |
| 1 | Blade terminals |
| Key for rated power | |
| A | AC 10 V – AC 250 V 0.1 ... 4 A |
| | DC 12 V 0.1 ... 4 A |
| | DC 24 V 0.1 ... 4 A |
| | DC 60 V 0.1 ... 1 A |
| | DC 110 V 0.1 ... 0.5 A |
| | DC 220 V 0.1 ... 0.25 A |
| B | AC 5 V – AC 250 V 5 ... 100 mA |
| | DC 5 V – DC 250 V 5 ... 100 mA |
| Supply status | |
| M | Module mounted to 3120 circuit breaker |
| X3120- S 0 1 A M | Ordering example |

Dimensions – auxiliary contact module

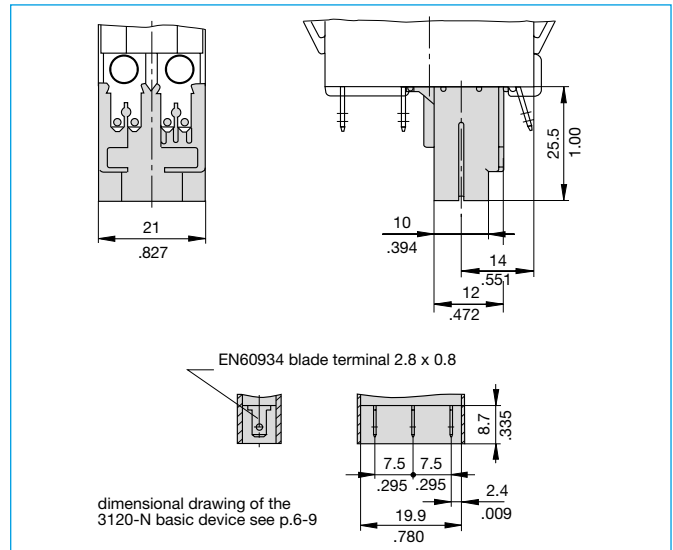

Schematic diagram

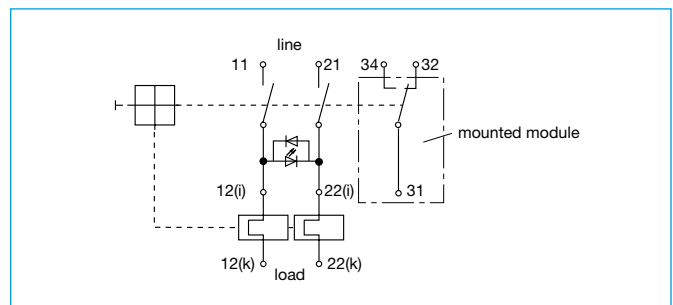

Technical data

| | |
|------------------------------------|--|
| Rated voltage | AC 250 V, DC 250 V |
| Current rating | 0.1...4 A / 5...100 mA |
| Typical life | 50,000 cycles |
| Ambient temperature | -30 ... 60 °C |
| Dielectric strength | |
| between main and auxiliary circuit | Test voltage AC 3,000 V |
| Insulation resistance | > 100 MΩ (DC 500 V) |
| Vibration | 6 g (57-500 Hz), ± 0.46 mm (10-57 Hz) Test to IEC 60068-2-6, Test Fc 10 frequency cycles/axis |
| Shock | 15 g (11 ms) Test to IEC 60068-2-27, Test Ea |
| Corrosion | 96 hours at 5 % salt mist, Test to IEC 60068-2-11, Test Ka |
| Humidity | 240 hours in 95 % RH Test to IEC 60068-2-78, Test Cab |
| Mass | approx. 41 g (including base device) |

All information and data given on our products are accurate and reliable to the best of our knowledge, but E-T-A does not accept any responsibility for the use in applications which are not in accordance with the present specification. E-T-A reserves the right to change specifications at any time in the interest of improved design and performance. Dimensions are subject to change without notice. Please enquire for the latest dimensional drawing with tolerances if required. All dimensions, data, pictures and descriptions are for information only and are not binding. Amendments, errors and omissions excepted. Part numbers of the devices may differ from their marking.

Description X3120-M remote trip module

By applying voltage (pulse) to the remote trip module the 3120-N circuit breaker can be tripped electrically.

Note: Not possible in combination with PT terminals.

Typical applications

Electrical remote trip of safety systems.

Ordering information

| | | | | |
|-------------------------|--------|---|---|--|
| Type no. | X3120 | | | Module for 3120-N device |
| Module | M | | | Magnetic relay trip module |
| Design | 2 | | | Magnetic coil physically isolated from device |
| Terminal design | P7 | | | Blade terminals |
| Supply status | M | | | Module is only supplied mounted to base device |
| Rated voltage | | | | AC 120, 230 V DC 12, 24 V |
| Ordering example | X3120- | M | 2 | P7 M -12 V |

Standard voltage ratings and typical internal resistance values

| Rated voltage | Internal resistance (Ω) | Rated voltage | Internal resistance (Ω) |
|---------------|-------------------------|---------------|-------------------------|
| DC 12 V | 0.78 | AC 120 V | 71.0 |
| DC 24 V | 3.3 | AC 230 V | 312 |

Dimensions - remote trip module

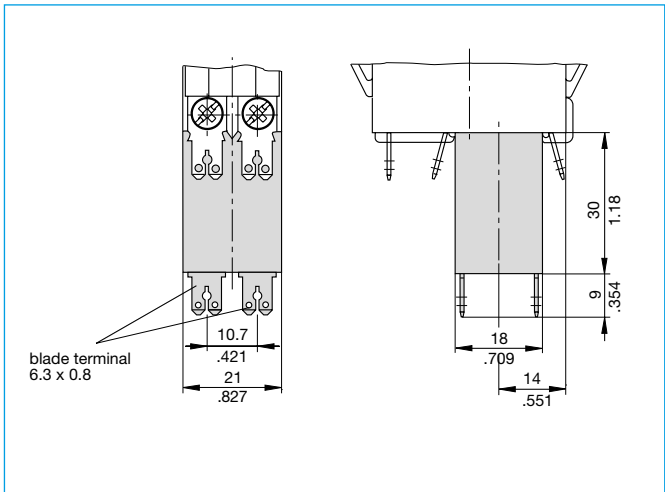

Schematic diagram

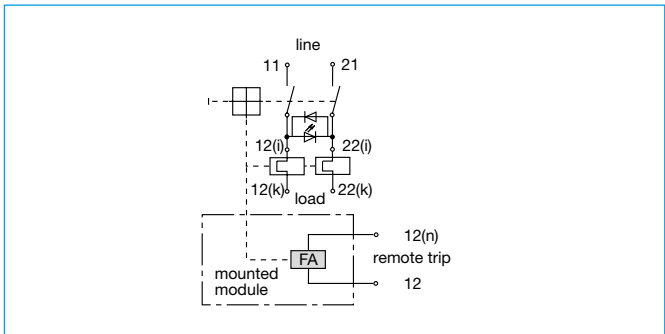

Technical data

| | |
|---------------------------------------|---|
| Voltage ratings | AC 120...230 V; DC 12...24 V |
| Power consumption | approx. 200 Watt |
| Pulse operation | 20 ms < t _{on} < 100 ms t _{off} > 10 sec |
| Trip time | < 20 ms |
| Typical life | 50,000 operations at U _N |
| Ambient temperature | -30 ... 60 °C |
| Dielectric strength | |
| between main and trip current circuit | Test voltage AC 3,000 V |
| Insulation resistance | > 100 MΩ (DC 500 V) |
| Vibration | 8 g (57-500 Hz), ± 0.61 mm (10-57 Hz) Test to IEC 60068-2-6, Test Fc 10 frequency cycles/axis |
| Shock | 30 g (11 ms) Test to IEC 60068-2-27, Test Ea |
| Corrosion | 96 hours at 5 % salt mist, Test to IEC 60068-2-11, Test Ka |
| Humidity | 240 hours in 95 % RH Test to IEC 60068-2-78, Test Cab |
| Mass | approx. 56 g (including base device) |

All information and data given on our products are accurate and reliable to the best of our knowledge, but E-T-A does not accept any responsibility for the use in applications which are not in accordance with the present specification. E-T-A reserves the right to change specifications at any time in the interest of improved design and performance. Dimensions are subject to change without notice. Please enquire for the latest dimensional drawing with tolerances if required. All dimensions, data, pictures and descriptions are for information only and are not binding. Amendments, errors and omissions excepted. Part numbers of the devices may differ from their marking.

Description

The 3120- N...-...M1-... thermal-magnetic circuit breaker/switch combination unites overcurrent protection and the function of an ON/OFF switch within a single component. The integral thermobimetal ensures ideally matched overload protection. The magnetic trip module trips the circuit breaker/switch combination at overload currents from four times rated current within milliseconds.

The 3120- N...-...M1-... meets the fire resistance requirements to EN 60335-1: 2007-02 Safety of household and similar electrical appliances.

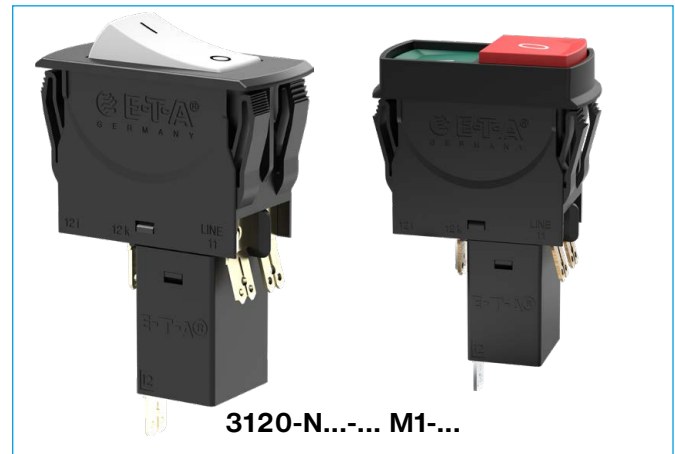

Typical applications

Electric motors, household appliances and office machines, electrical tools, power supplies, charging rectifiers

Current ratings and internal resistance values

| Current rating (A) | Internal resistance per pole (Ω) | |
|--------------------|----------------------------------|---------|
| | Thermal-magnetic | Thermal |
| 0.1 | 165 | 94 |
| 0.2 | 42.5 | 24 |
| 0.3 | 20.2 | 12 |
| 0.4 | 9.7 | 5.40 |
| 0.5 | 7.17 | 4.30 |
| 0.6 | 4.9 | 3 |
| 0.8 | 2.65 | 1.50 |
| 1 | 1.49 | 0.9 |
| 1.2 | 1.25 | 0.7 |
| 1.5 | 0.74 | 0.45 |
| 2 | 0.49 | 0.29 |
| 2.5 | 0.20 | 0.0785 |
| 3 | 0.14 | 0.0595 |
| 3.5 | 0.114 | 0.0565 |
| 4 | 0.092 | 0.0435 |
| 5 | 0.06 | 0.0325 |
| 6 | 0.043 | 0.0215 |
| 7 | 0.030 | 0.0215 |
| 8 | 0.029 | 0.02 |
| 10 | 0.021 | 0.02 |
| 12 | < 0.02 | < 0.02 |
| 14 | < 0.02 | < 0.02 |
| 15 | < 0.02 | < 0.02 |
| 16 | < 0.02 | < 0.02 |

Dimensions – magnetic trip module

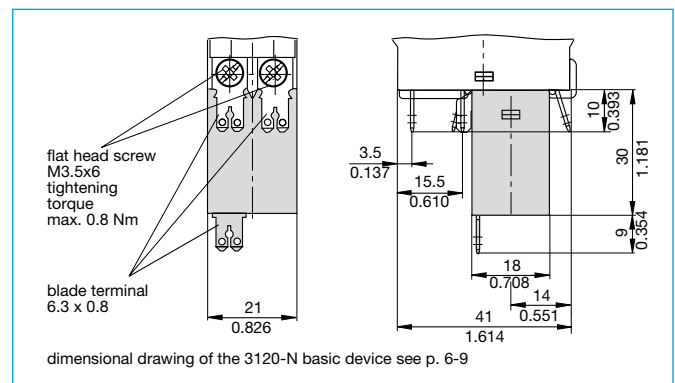

Schematic diagrams

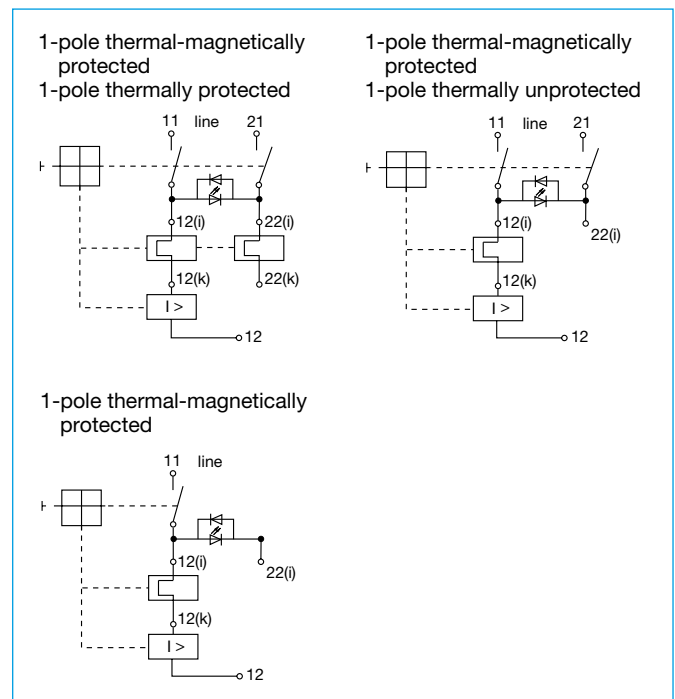

Technical data

For detailed technical information please see www.e-t-a.de/ti_e

| | |
|----------------------|--|
| Rated voltage | AC 240 V, DC 50 V (AC 415 V upon request) |
| Current rating range | 0.1 ... 16 A |

Typical life 1-pole

| | | |
|-----------|--------------|---|
| AC 240 V: | 0.1 ... 16 A | 30,000 cycles at 1 x I _N , inductive |
| DC 50 V: | 0.1 ... 4 A | 30,000 cycles at 1 x I _N , inductive |
| | 4.5 ... 16 A | 30,000 cycles at 1 x I _N , resistive |
| DC 28 V: | 0.1 ... 16 A | 30,000 cycles at 1 x I _N , inductive |

Typical life 2-pole

| | | |
|-----------|--------------|---|
| AC 240 V: | 0.1 ... 16 A | 50,000 cycles at 1 x I _N , inductive |
| DC 50 V: | 0.1 ... 16 A | 50,000 cycles at 1 x I _N , inductive |

| | |
|-------------------------------------|---|
| Ambient temperature | -30 ... 60 °C |
| Insulation coordination (IEC 60664) | 2.5 kV / 2 Reinforced insulation in the operating area |
| Dielectric strength | |
| Operating area | Test voltage AC 3000 V |
| Current path/current path | Test voltage AC 1500 V |
| Insulation resistance | > 100 MΩ (DC 500 V) |

Rupture capacity I_{cn} (IEC/EN 60934)

| | I _N | U _N | I _{cn} |
|----------------|----------------|-----------------------|----------------------|
| 1-pole, 2-pole | 0.1 ... 2 A | AC 240 V / DC 28 V | 100 x I _N |
| 1-pole | 0.1 ... 10 A | DC 50 V | 50 A |
| 1-pole | 2.5 ... 16 A | AC 240 V / DC 28 V | 200 A |
| 2-pole | 0.1 ... 2 A | DC 50 V | 10 x I _N |
| 2-pole | 2.5 ... 16 A | DC 50 V | 250 A |
| 2-pole | 2.5 ... 16 A | AC 240 V / DC 28 V | 300 A |

Interrupting capacity I_{nc} (UL 1077)

| | I _N | U _N | I _{nc} |
|----------------|----------------|----------------|-----------------|
| 1-pole, 2-pole | 0.1 ... 10 A | AC 250 V | 2,000 A, C, 1 |
| 1-pole, 2-pole | 0.1 ... 16 A | AC 125 V | 1,000 A, C, 1 |

Degree of protection (IEC 60529)

| | |
|------------------|--|
| Operating area | IP40 With water splash protection IP65 |
| Terminal area | IP00 With water splash protection IP64 |
| Vibration | 8 g (57-500 Hz) ± 0.61 mm (10-57 Hz) Test to IEC 60068-2-6, Test Fc 10 frequency cycles/axis |
| Shock resistance | 30 g (11 ms) Test to IEC 60068-2-27, Test Ea |
| Corrosion | 96 hours in 5 % salt mist Test to IEC 60068-2-11, Test Ka |
| Humidity | 240 hours in 95 % RH Test to IEC 60068-2-78, Test Cab |
| Mass | approx. 53 g (2-pole) approx. 50 g (1-pole) |

Approvals

| Approval authority | Standard | Rated voltage | Current rating range |
|--------------------|--------------|----------------------|------------------------------|
| VDE | IEC/EN 60934 | AC 240 V DC 50 V | 0.1 ... 16 A 0.1 ... 16 A |
| UL | UL 1077 | AC 250 V AC 125 V | 0.1 ... 10 A 0.1 ... 16 A |
| CSA | C22.2 No 235 | AC 250 V AC 125 V | 0.1 ... 10 A 0.1 ... 16 A |
| CQC (CCC) | GB 17701 | AC 240 V DC 50 V | 0.1 ... 16 A 0.1 ... 16 A |

Time/current characteristics

Total switch-off time at rated voltage and 1- or 2-pole load
Ambient temperature 23 °C

0.1...2 A AC/DC ¹⁾

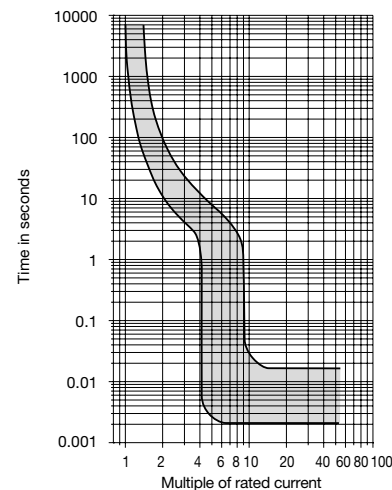

2.5...16 A AC/DC ¹⁾

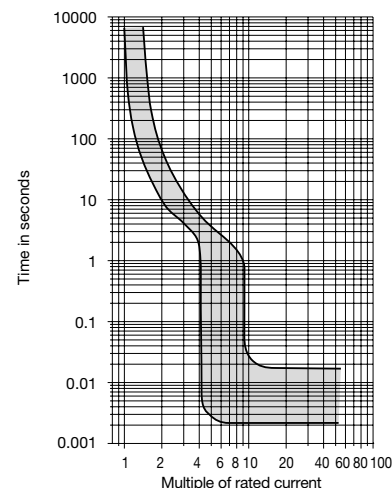





¹⁾With DC, the magnetic response values are higher by a factor of approx. 1.25.

The time/current characteristics depend on the ambient temperature. In order to eliminate nuisance or late tripping, please multiply the current rating of the circuit breaker by a temperature factor (also refer to chapter Technical Information).

| ambient temperature [°C] | -30 | -20 | -10 | 0 | 23 | 40 | 50 | 60 |
|--------------------------|-----|------|------|------|----|------|------|------|
| Temperature factor | 0.8 | 0.84 | 0.88 | 0.92 | 1 | 1.08 | 1.14 | 1.23 |



Ordering information

| | |
|--|--|
| Type no. | |
| 3120 | Thermal-magnetic circuit breaker/switch combination with rocker actuation |
| Mounting method | |
| N3 | Snap-in, mounting cut-out 50.5 x 21.5 mm |
| N5 | Snap-in, mounting cut-out 44.5 x 22 mm |
| Number of poles | |
| 1 | 1-pole switching, 1-pole thermal-magnetically protected |
| 2 | 2-pole switching, 2-pole protected (pole 1: thermal-magnetically protected, pole 2: thermally protected) |
| 5 | 2-pole switching, 1-pole thermal-magnetically protected |
| Style | |
| 1 | Standard |
| 3 | With actuator guard |
| 4 | With accordion-style seal, IP65 |
| 6 | Version with shorter flange (only for mounting method N5) |
| A | With actuator guard and cross-hole |
| Terminal design | |
| P7 | Blade terminals |
| H7 | As P7, terminals 11 and 21 with additional flat head screws M3.5 |
| N7 | As P7, with additional shunt terminals 12(i) and 22(i) |
| G7 | As N7, terminals 11 and 21 with additional flat head screws M3.5 |
| Trip curve | |
| M1 | Medium delay, thermal 1.01-1.4 x I _N ; magnetic 4-9 x I _N AC |
| Actuator | |
| W | Rocker |
| Rocker colour and illumination | |
| Opaque | |
| 01 . | Black without illumination |
| 02 . | White without illumination |
| 04 . | Red without illumination |
| Translucent (when named with Y/R/T/G the rocker is illuminated) | |
| 12 . (Y) | White (illuminated) |
| 14 . (R) | Red (illuminated) |
| 15 . (Y) | Orange (illuminated) |
| 16 . (T) | Blue (illuminated) |
| 19 . (G) | Green (illuminated) |
| Marking of rocker | |
| A (not for mounting method 4) | |
| D |  |
| F |  |
| K |  |
| L |  |
| X |  |

| | |
|--|-----------------------------------|
| 3120-N5 2 4 - P7 M1-W 19 D G ... | Ordering example |
| Illumination voltage range (= operating voltage) | |
| 1 | DC 12 V |
| 2 | DC 24 V |
| 3 | AC 115 V |
| 4 | AC 230 V |
| 5 | DC 48 V |
| 6 | AC 400 V (for 2-pole versions) |
| Current rating | |
| 0.1 ... 16 A | |
| 3120-N5 2 4 - P7 M1-W 19 D G 4 - 16 A | Ordering example |

3120-N5 2 4 - P7 M1-W 19 D G ... Ordering example



1

Ordering information

| | |
|---|--|
| Type no. | |
| 3120 | Thermal-magnetic circuit breaker/switch combination with push button actuation |
| Mounting method | |
| N3 | Snap-in, mounting cut-out 50.5 x 21.5 mm |
| N5 | Snap-in, mounting cut-out 44.5 x 22 mm |
| Number of poles | |
| 1 | 1-pole switching, 1-pole thermal-magnetically protected |
| 2 | 2-pole switching, 2-pole protected (pole 1: thermal-magnetically protected, pole 2: thermally protected) |
| 5 | 2-pole switching, 1-pole thermal-magnetically protected |
| Style | |
| D | With actuator guard |
| E | With actuator guard and water splash cover IP54 |
| F | With power-on protection |
| V | With power-on protection and water splash cover IP54 |
| Terminal design | |
| P7 | Blade terminals |
| H7 | As P7, terminals 11 and 21 with additional flat head screws M3.5 |
| N7 | As P7, with additional shunt terminals 12(i) and 22(i) |
| G7 | As N7, terminals 11 and 21 with additional flat head screws M3.5 |
| Trip curve | |
| M1 | Medium delay, thermal 1.01-1.4 x I _N ; magnetic 4-9 x I _N AC |
| Actuator | |
| S | Two push buttons |
| Colour of push button/illumination (Style D and F without water splash protection) | |
| GRD | Green/red without illumination |
| GRDXG | Green with LED illumination/red without illumination |
| Colour of push button/illumination (Style E and V with water splash protection) | |
| GRX | Green/red without illumination |
| GRDXG | Green with LED illumination/red without illumination |
| Illumination voltage range (= operating voltage) | |
| 1 | DC 12 V |
| 2 | DC 24 V |
| 3 | AC 115 V |
| 4 | AC 230 V |
| 5 | DC 48 V |
| 6 | AC 400 V (for 2-pole versions) |
| Current rating | |
| 0.1...16 A | |
| 3120-N3 5 V - P7 M1-S GRXG - 16 A Ordering example | |

Please observe our minimum ordering quantities.

Ordering information

| | |
|---|---|
| Type no. | |
| 3120 | Thermal magnetic resettable circuit breaker with push button |
| Mounting method | |
| N3 | Snap-in, mounting cut-out 50.5 x 21.5 mm |
| N5 | Snap-in, mounting cut-out 44.5 x 22 mm |
| Number of poles | |
| 1 | 1-pole thermal-magnetically protected |
| 2 | 2-pole protected (1 1: thermal-magnetically protected, pole 2: thermally protected) |
| 5 | 2-pole, 1-pole thermal-magnetically protected |
| Style | |
| G | Resettable circuit breaker |
| Terminal design | |
| P7 | Blade terminals |
| H7 | As P7, terminals 11 and 21 with additional flat head screws M3.5 |
| N7 | As P7, with additional shunt terminals 12(i) and 22(i) |
| G7 | As N7, terminals 11 and 21 with additional flat head screws M3.5 |
| Trip curve | |
| M1 | Medium delay, thermal- 1.01-1.4 x I _N ; magnetic 4-9 x I _N AC |
| Actuator | |
| D | One push button |
| Colour of push button | |
| 01 | Black |
| 02 | White opaque |
| 04 | Red opaque (UL/CSA approval only) |
| 09 | Green opaque |
| Marking of the push button | |
| X | Without marking |
| Current rating | |
| 0.1...16 A | |
| 3120-N3 2 G - P7 M1-D 01 - X 16 A Ordering example | |

Please observe our minimum ordering quantities.

Customer-specific solutions

Looking for a version you cannot find in our order numbering code? Please get in touch.