

March 1995

## Axial Lead Metal-Oxide Varistors

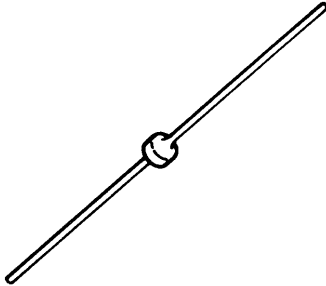

MA SERIES

### Features

- 3mm Diameter Disc Size
- Wide Operating Voltage Range  $V_{M(AC)RMS}$  ..... 9V to 264V
- Available in Tape and Reel Packaging for Use With Automatic Insertion Equipment

### Description

MA series transient surge suppressors are axial-lead metal-oxide varistors for use in a wide variety of industrial and commercial electronic equipment. The construction of these

3mm diameter disc-type axial lead varistors make them particularly useful in automatic insertion equipment.

**Absolute Maximum Ratings** For ratings of individual members of a series, see Device Ratings and Specifications chart

	MA SERIES	UNITS
Continuous:		
Steady State Applied Voltage:		
AC Voltage Range ( $V_{M(AC)RMS}$ ) .....	9 to 264	V
DC Voltage Range ( $V_{M(DC)}$ ) .....	13 to 365	V
Transient:		
Peak Pulse Current ( $I_{TM}$ )		
For 8/20 $\mu$ s Current Wave (See Figure 2) .....	40 to 100	A
Single Pulse Energy Range		
For 10/1000 $\mu$ s Current Wave ( $W_{TM}$ ) .....	0.06 to 1.7	J
Operating Ambient Temperature Range ( $T_A$ ) .....	-55 to +85	$^{\circ}$ C
Storage Temperature Range ( $T_{STG}$ ) .....	-55 to +125	$^{\circ}$ C
Temperature Coefficient ( $\alpha_V$ ) of Clamping Voltage ( $V_C$ ) at Specified Test Current .....	<0.01	%/ $^{\circ}$ C
Hi-Pot Encapsulation (Isolation Voltage Capability) .....	1000	V
(Dielectric must withstand indicated DC voltage for one minute per MIL-STD 202, Method 301)		
Insulation Resistance .....	1000	M $\Omega$

## Specifications MA Series

### Device Ratings and Specifications

MODEL NUMBER	DEVICE MARKING	MAXIMUM RATINGS (+85°C)				SPECIFICATIONS (+25°C)					
		CONTINUOUS		TRANSIENT		VARISTOR VOLTAGE AT 1mA DC TEST CURRENT			MAX CLAMPING VOLT AT I <sub>P</sub> VALUE CURRENT (8/20μs)	TYPICAL CAPACITANCE	
		V <sub>RMS</sub>	V <sub>DC</sub>	ENERGY (10/1000μs)	PEAK CURRENT (8/20μs)						
		V <sub>M(AC)</sub>	V <sub>M(DC)</sub>	W <sub>TM</sub>	I <sub>TM</sub>	MIN	V <sub>N(DC)</sub>	MAX	I <sub>P</sub> = 2.0A	f = 1MHz	
		(V)	(V)	(J)	(A)	(V)	(V)	(V)	(V)	(pF)	
V18MA1A	18A	9	13	0.06	40	14	18	23	49	550	
V18MA1B	18B	10	14	0.07	40	15	18	21	44	550	
V18MA1S	18S	10	14	0.06	40	15	18	21	49	550	
V22MA1A	22A	10	15	0.09	40	16	22	28	55	410	
V22MA1B	22B	14	18	0.10	40	19	22	26	51	410	
V22MA1S	22S	14	18	0.09	40	19	22	26	55	410	
V27MA1A	27A	13	19	0.10	40	21	27	34	67	370	
V27MA1B	27B	17	22	0.11	40	24	27	31	59	370	
V27MA1S	27S	17	22	0.10	40	24	27	31	67	370	
V33MA1A	33A	18	23	0.13	40	26	33	40	73	300	
V33MA1B	33B	20	26	0.15	40	29.5	33	36.5	67	300	
V33MA1S	33S	20	26	0.14	40	29.5	33	36.5	73	300	
V39MA2A	39A	22	28	0.16	40	31	39	47	86	250	
V39MA2B	39B	25	31	0.18	40	35	39	43	79	250	
V39MA2S	39S	25	31	0.17	40	35	39	43	86	250	
V47MA2A	47A	27	34	0.19	40	37	47	57	99	210	
V47MA2B	47B	30	38	0.21	40	42	47	52	90	210	
V47MA2S	47S	30	38	0.19	40	42	47	52	99	210	
V56MA2A	56A	32	40	0.23	40	44	56	68	117	180	
V56MA2B	56B	35	45	0.25	40	50	56	62	108	180	
V56MA2S	56S	35	45	0.23	40	50	56	62	117	180	
V68MA3A	68A	38	48	0.26	40	54	68	82	138	150	
V68MA3B	68B	40	56	0.30	40	61	68	75	127	150	
V68MA3S	68S	40	56	0.27	40	61	68	75	138	150	
V82MA3A	82A	45	60	0.33	40	65	82	99	163	120	
V82MA3B	82B	50	66	0.37	40	73	82	91	150	120	
V82MA3S	82S	50	66	0.34	40	73	82	91	163	120	
V100MA4A	100	57	72	0.40	40	80	100	120	200	100	
V100MA4B	101	60	81	0.45	40	90	100	110	185	100	
V100MA4S	102	60	81	0.42	40	90	100	110	200	100	
V120MA1A	120	72	97	0.40	100	102	120	138	220	40	
V120MA2B	121	75	101	0.50	100	108	120	132	205	40	
V120MA2S	122	75	101	0.46	100	108	120	132	220	40	
V150MA1A	150	88	121	0.50	100	127	150	173	255	32	
V150MA2B	151	92	127	0.60	100	135	150	165	240	32	
V180MA1A	180	105	144	0.60	100	153	180	207	310	27	
V180MA3B	181	110	152	0.70	100	162	180	198	290	27	
V220MA2A	220	132	181	0.80	100	187	220	253	380	21	
V220MA4B	221	138	191	0.90	100	198	220	242	360	21	
V270MA2A	270	163	224	0.90	100	229	270	311	460	17	
V270MA4B	271	171	235	1.00	100	243	270	297	440	17	
V330MA2A	330	188	257	1.00	100	280	330	380	570	14	
V330MA5B	331	200	274	1.10	100	297	330	363	540	14	
V390MA3A	390	234	322	1.20	100	331	390	449	670	12	
V390MA6B	391	242	334	1.30	100	351	390	429	640	12	
V430MA3A	430	253	349	1.50	100	365	430	495	740	11	
V430MA7B	431	264	365	1.70	100	387	430	473	700	11	

NOTE: Average power dissipation of transients not to exceed 200mW.

### Power Dissipation Ratings

Continuous power dissipation capability is not an applicable design requirement for a suppressor, unless transients occur in rapid succession. Under this condition, the average power dissipation required is simply the energy (watt-seconds) per pulse times the number of pulses per second. The power so developed must be within the specifications shown on the Device Ratings and Specifications table for the specific device. Furthermore, the operating values need to be derated at high temperatures as shown in Figure 1. Because varistors can only dissipate a relatively small amount of average power they are, therefore, not suitable for repetitive applications that involve substantial amounts of average power dissipation.

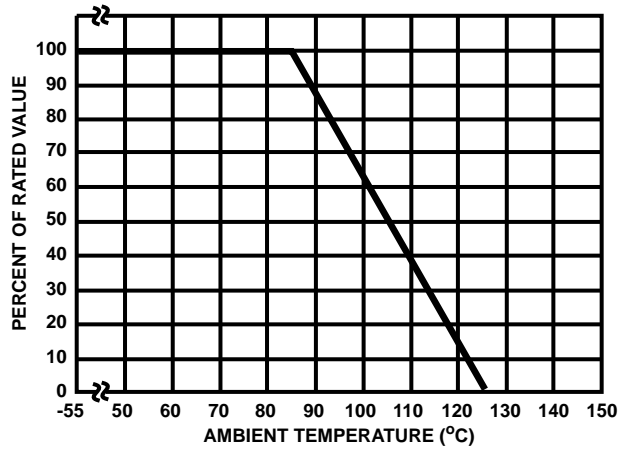
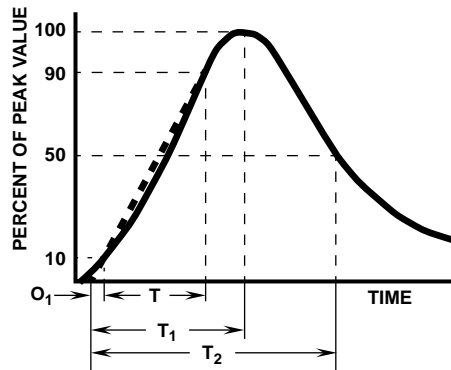

FIGURE 1. CURRENT, ENERGY AND POWER DERATING CURVE



$O_1$  = Virtual Origin of Wave  
 $T$  = Time From 10% to 90% of Peak  
 $T_1$  = Virtual Front Time =  $1.25 \cdot t$   
 $T_2$  = Virtual Time to Half Value (Impulse Duration)

Example: For an  $8/20\mu s$  Current Waveform:  
 $8\mu s = T_1$  = Virtual Front Time  
 $20\mu s = T_2$  = Virtual Time to Half Value

FIGURE 2. PEAK PULSE CURRENT TEST WAVEFORM

### Transient V-I Characteristics Curves

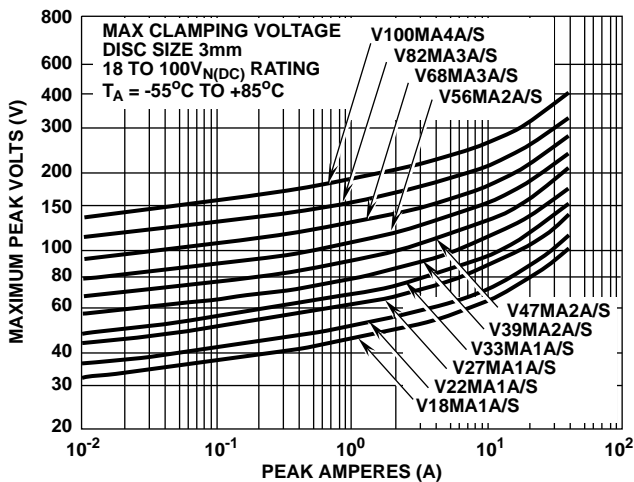

FIGURE 3. CLAMPING VOLTAGE FOR V18MA1A/S - V100MA4A/S

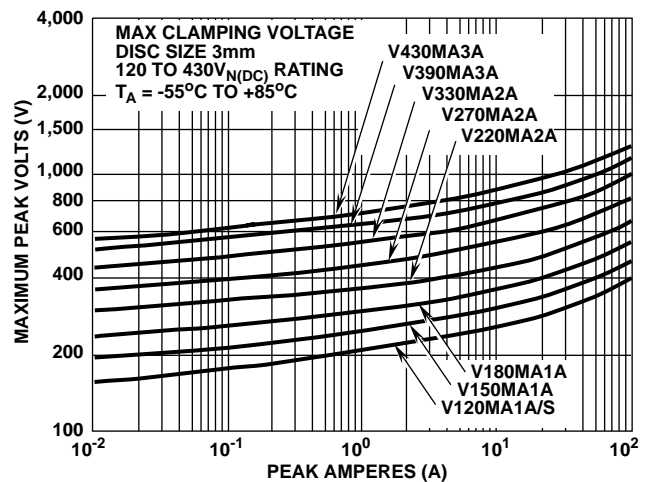

FIGURE 4. CLAMPING VOLTAGE FOR V120MA1A/S - V430MA3A

Transient V-I Characteristics Curves (Continued)

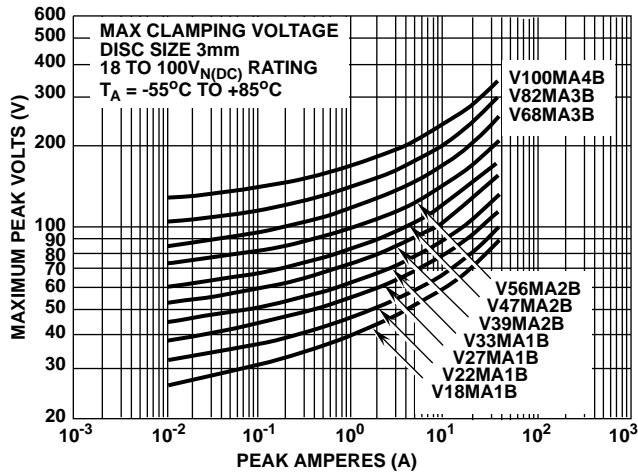

FIGURE 5. CLAMPING VOLTAGE FOR V18MA1B - V100MA4B

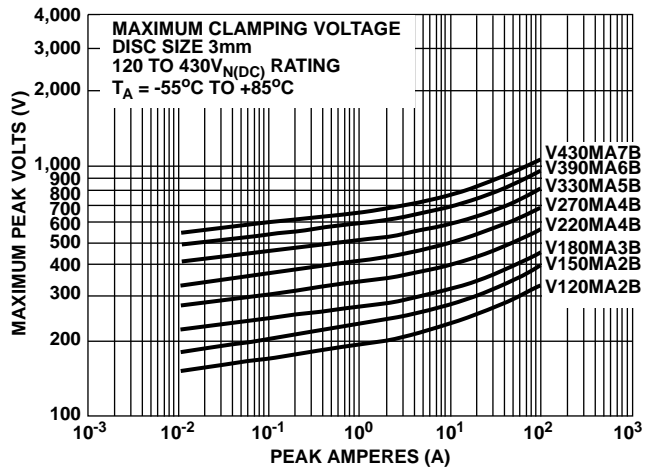

FIGURE 6. CLAMPING VOLTAGE FOR V120MA2B - V430MA7B

Pulse Rating Curves

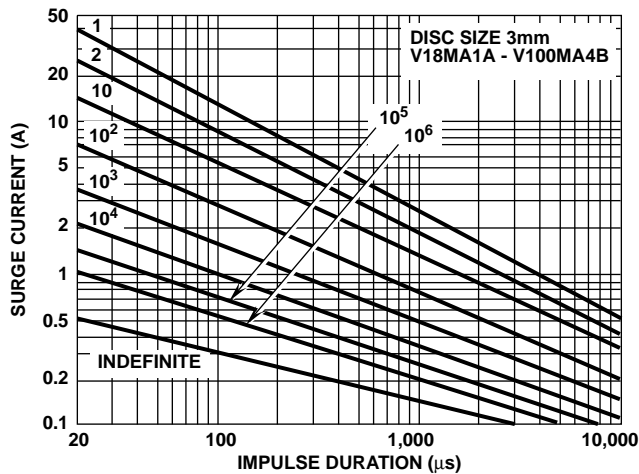

FIGURE 7. SURGE CURRENT RATING CURVES FOR V18MA SERIES - V100MA SERIES

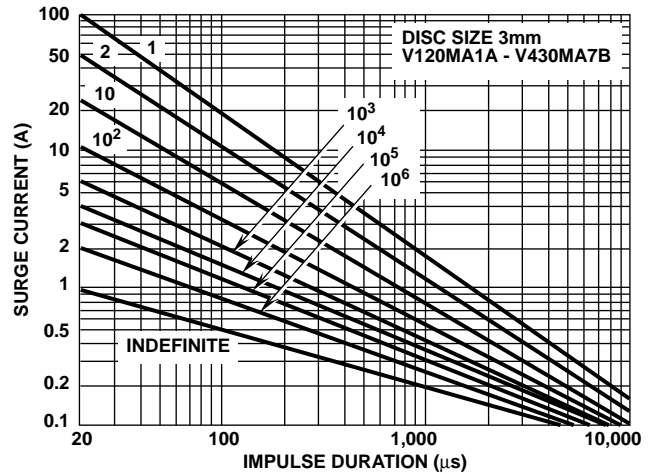
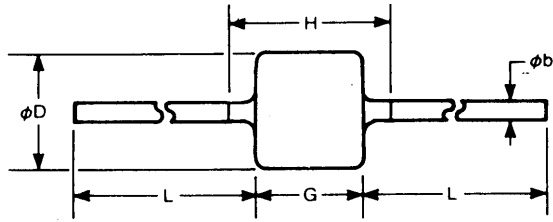

FIGURE 8. SURGE CURRENT RATING CURVES FOR V120MA SERIES - V430MA SERIES

NOTE: If pulse ratings are exceeded, a shift of  $V_{N(DC)}$  (at specified current) of more than  $\pm 10\%$  could result. This type of shift, which normally results in a decrease of  $V_{N(DC)}$ , may result in the device not meeting the original published specifications, but it does not prevent the device from continuing to function, and to provide ample protection.

## MA Series

### Package Outline Dimensions



SYMBOL	INCHES		MILLIMETERS	
	MIN	MAX	MIN	MAX
Øb	0.024	0.026	0.61	0.66
ØD	0.135	0.177	3.43	4.5
G	0.098	0.177	3.43	4.5
H	0.118	0.236	3.0	6.0
L	1.130	1.220	28.70	31.0

Typical Weight = 25g

### Tape and Reel Specification

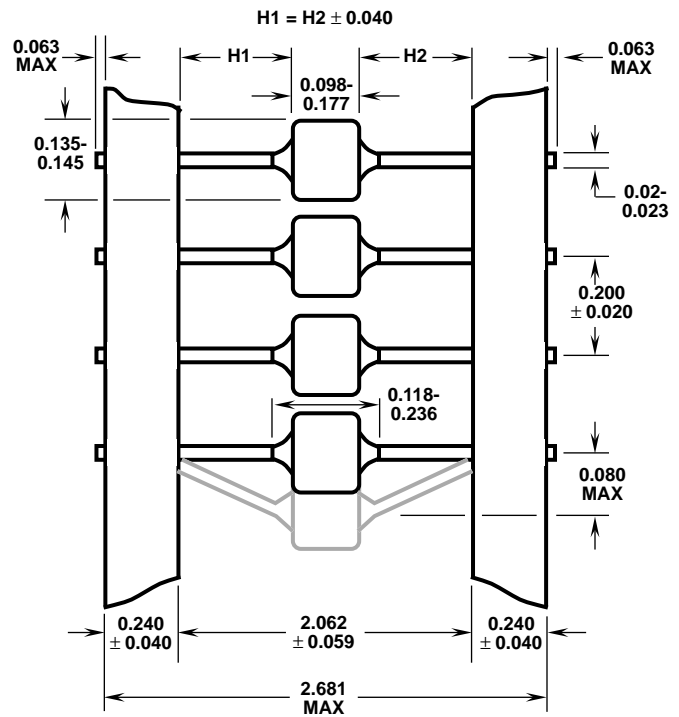

- Conforms to EIA Standard RS-296E

### Ordering Information

- This series is supplied either in bulk or tape and reel. To order in tape and reel the standard model numbers are changed by replacing the model letter "A" with "T".

Example:

STD. CAT. MODEL	ORDER AS
V18MA1A	V18MT1A
Bulk	Quantity Per Reel: 5,000