

Installation guide

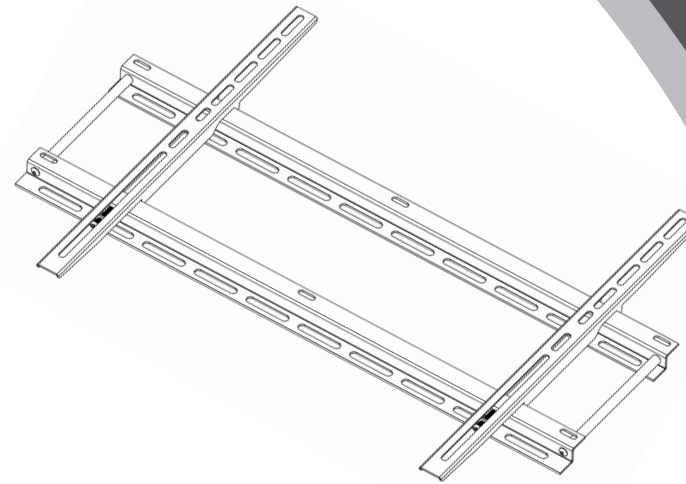

Thank you for choosing OMP Global Style.

omp
AMERICAS

200 Norfinch Drive
Toronto, Ontario,
Canada
M3N 1Y4

Tel: 1-416-667-9909

Email: americas@omp-global.com

omp
EUROPE/MIDDLE EAST

Common Lane
Setchey, Kings Lynn
Norfolk, PE33 0AT
England

Tel: 44-1553-813-300

Email: europe@omp-global.com

omp
ASIA PACIFIC

1D Quadrant Dr,
Gracefield,
Lower Hutt, 5010
New Zealand

Tel: 64-4-586-6677

Email: asiapacific@omp-global.com

MOUNTING INSTALLATION INSTRUCTIONS

Designed for medium/large flat panels (40"-54") to install to a vertical wall.
Maximum load capacity: 90kgs (200lbs).

CAUTION:

If you do not understand these instructions, or have doubts about the safety of the installation, please call a qualified installer or contact us. We will provide assistance for any safety issues and resolve any missing component problems. Please check carefully to make sure there are no missing or defective parts. Do not use components with defects, as wrong installation may lead to component damage or serious injury to the user. Do not use this product for any purpose other than the original intended use. The hardware supplied for this product cannot be used on a steel stud wall, old cinder block wall or a hollow wall. If you cannot determine the nature of a wall, please consult a qualified installer. Our company will not be held responsible for damage or loss caused by wrong installation or assembly. Regular cleaning of this product with a clean dry cloth is usually sufficient, but for stubborn marks, wipe over gently with a clean damp cloth. Never use strong detergents or abrasives, as these may damage the surface. There are many small components used in the construction of this unit, these loose items should be kept away from young children whilst assembling your unit. Do not exceed the maximum weight capacity for this product. Your installer is responsible for ensuring the safe installation of this product.

COMPONENTS

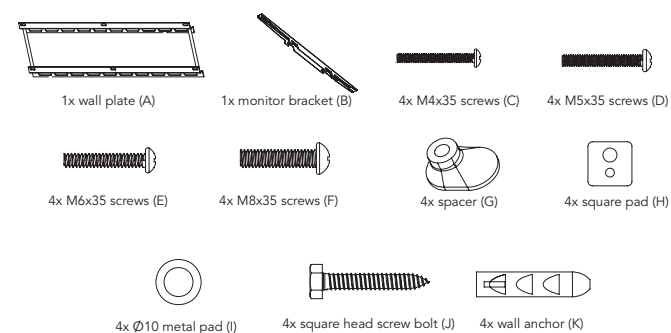

fig. 1

CAUTION:

Our company accepts responsibility for the safety of the mount and the television link, but does not accept responsibility for the link between the mount and the wall.

NECESSARY TOOLS:

6mm (1/4") drill bit, 13mm (1/2") masonry drill bit, (for concrete installation), 17mm (11/16") ratchet wrench, level, stud finder and a Philips head screwdriver.
The components and the attachments of this product are shown in fig. 1.

STEP 1

MOUNTING WALL PLATE

Four installation choices are covered: wood stud, brick, solid concrete and concrete block.

Wood stud installation:

The wall plate (A) must be anchored to the two wood studs at a distance over 30.5cm (12"). Use a high quality wood stud finder, to locate two adjacent studs. We suggest using an awl, or thin nails, to confirm the location of the wood stud (as shown in fig. 2.1). Use the 7mm (5/16") drill bit and drill 88mm (3 1/2") deep holes in each of wood stud's. Then use four 9mm (3/8") square head screw bolts (J) and four metal pads (I) and install the wall plate to the wall, please make sure the installation direction of the wall plate is correct (as shown in fig. 2.2).

Brick, solid concrete and concrete block installation:

Use wall plate (A) as a template and mark four holes in the wall. The left and right hole places should be spread as far apart as possible. Use the 13mm (1/2") drill bits to drill these holes making sure the depth is at least 88mm (3 1/2"). Put two bolts in the top row of slots and two in the bottom row. Make sure these holes are level, and that there is at least 15.2cm (6") between any two holes. Insert wall anchor (K) into these holes, making sure they are flush with the wall surface. Finally use the four square head screw bolts (J) to install the wall plate to the wall (as shown in fig. 2.3).

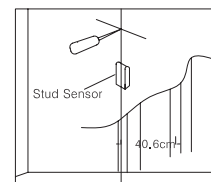

fig. 2.1

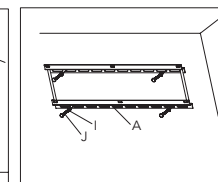

fig. 2.2

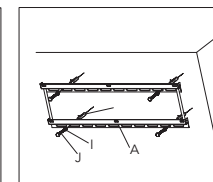
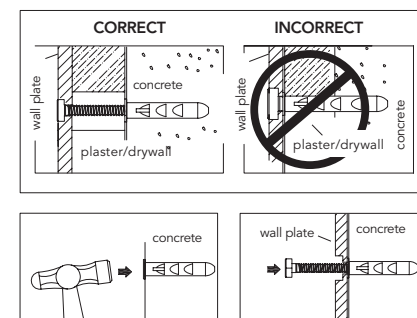

fig. 2.3

WARNING

When installing the wall mount onto a solid concrete wall, verify that you have a minimum of 35mm (1 3/8") of actual concrete thickness in the hole to be used for the concrete anchors. Do not drill into mortar joints! Be sure to mount in a solid part of the wall. It is suggested that a standard electric drill on a slow setting is used to drill the hole, instead of a hammer drill. The concrete must be 2000PSI minimum density.

The anchors must be seated firmly against the concrete or masonry. If mounting to a masonry wall covered with drywall/plaster, counter bore a hole through the drywall/plaster around the mounting hole location, so that the anchor can be seated directly against concrete or masonry.



STEP 2

SELECT THE CORRECT MOUNTING HARDWARE FOR YOUR TELEVISION

CAUTION: Always make sure the television is unplugged, before threading any bolt into the back panel! First find the screw holes in the television's back, then select the screws that fit the screw holes dimension.

IMPORTANT: If you cannot find the hardware that fits your television, please contact your local hardware shop.

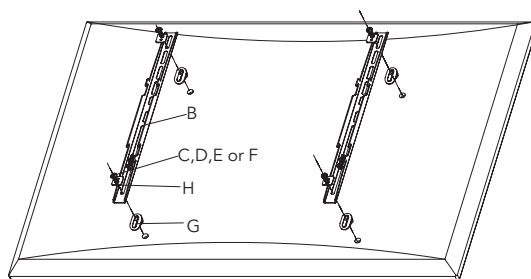

fig. 3

STEP 3

INSTALLATION OF THE MONITOR BRACKETS TO THE BACK OF THE TELEVISION

CAUTION: Never lay the television face down on the glass, it should be tilted or leaned against a wall or other solid surface. Laying the television face down on the glass, may lead to permanent damage.

Before installation, the monitor brackets (B) must be vertically placed and the distance from the television to the bracket should be as short as possible. For a television that has the slot in the back, thread the screws (C, D, E or F) through the square pad (H), the monitor bracket (B) and spacers (G) into the television. Finally tighten the screws firmly with a Philips screwdriver (as shown in fig. 3).

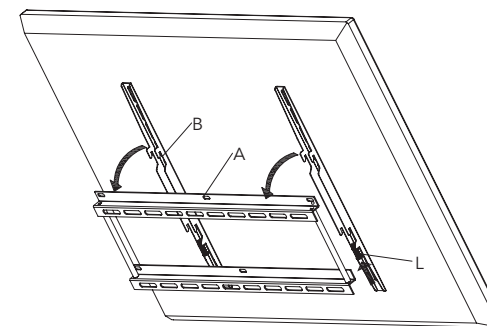

fig. 4

STEP 4

INSTALL THE MOUNT ASSEMBLY AND TELEVISION TO THE WALL PLATE

CAUTION: Some televisions are heavy, please lift and place carefully. We will not be held responsible for any accidental damage.

Attach the monitor brackets (B)'s hook to the wall plate (A)'s cross bar, then tighten screws (L, supplied attached to monitor bracket B) to secure the monitor brackets with the wall plate, to prevent the pivot arm assembly falling off the wall plate, (as shown in fig. 4).