

# UC SERIES

**Technical data**  
 Protection class IP30  
 (w/ Ventilation hole)  
 Protection class IP40  
 (w/o Ventilation hole)

## UC UNIVERSAL ALUMINIUM EXTRUSION CASE

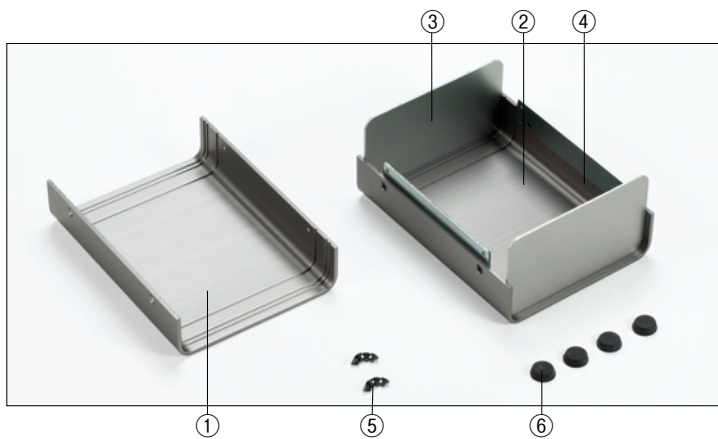
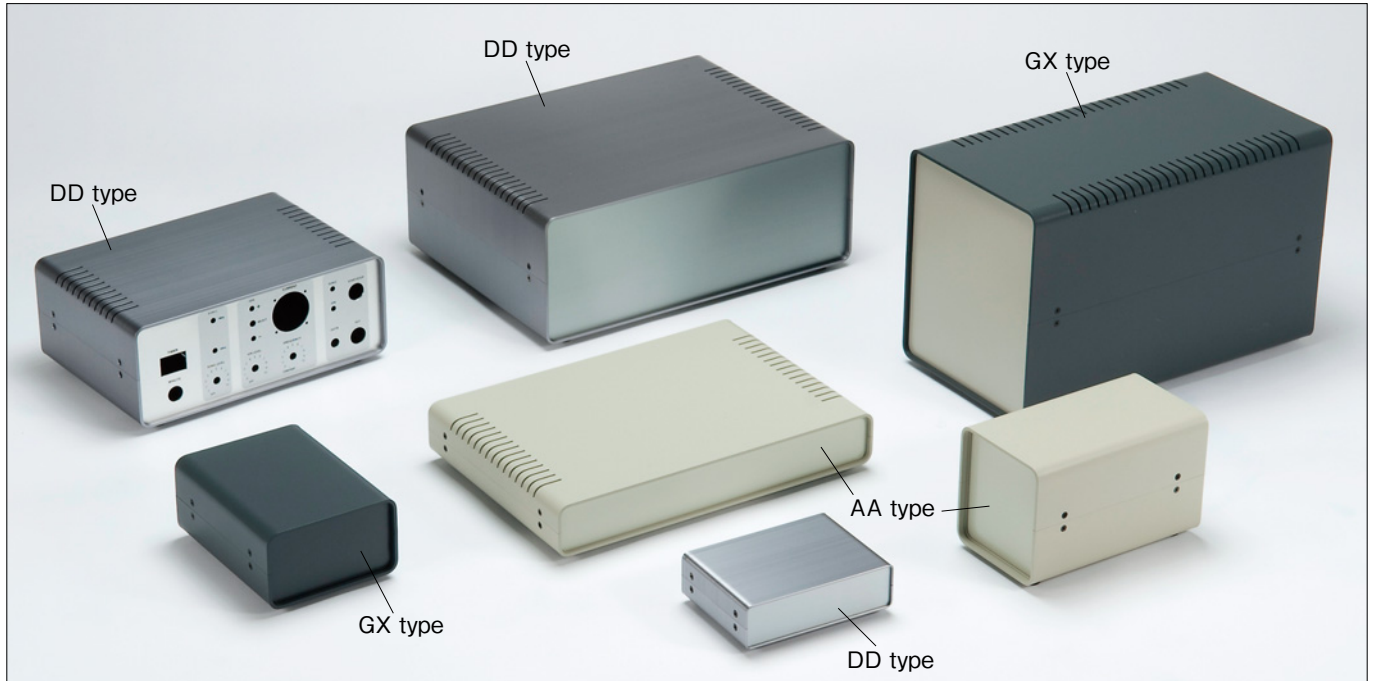

### FEATURE

- Case structure consisting of aluminium extrusion top/bottom covers and aluminium front/rear panels.
- GX type has mixed panel color.  
(1pcs of light gray, 1pcs of dark gray)
- Top and bottom covers have 2 or 3 built-in slots for inserting panels or your PCB.

### Components

Ref. #	Part name	Pcs	Material	Color / Finish
1	Top cover	1	Aluminium extrusion	Bronze anodized · Ivory painted · Dark gray painted
2	Bottom cover	1	Aluminium extrusion	Bronze anodized · Ivory painted · Dark gray painted
3	Panel	2	Aluminium t1.7	Bronze anodized
			Aluminium t1.5	Ivory · Dark gray · Light gray painted
4	Joint plate	2	Steel t2.0	Trivalent chromate
5	Screw	12	Steel M3	Black trivalent chromate
6	Rubber feet	4	Rubber	Black

### Accessories (Optional parts)

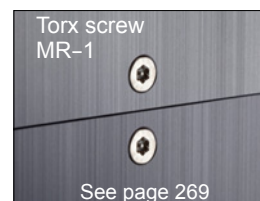
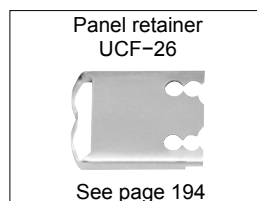
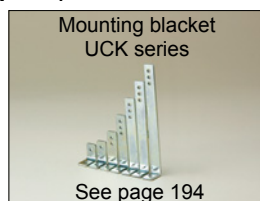
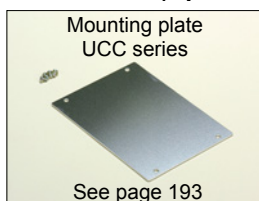

UC dimensions

• CAD data is downloadable from our website.

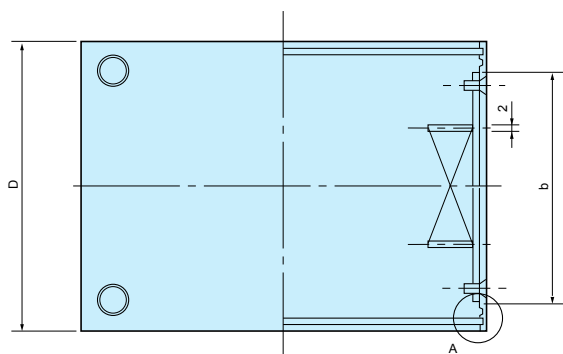
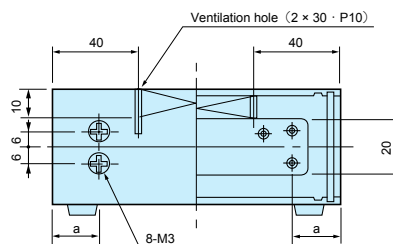
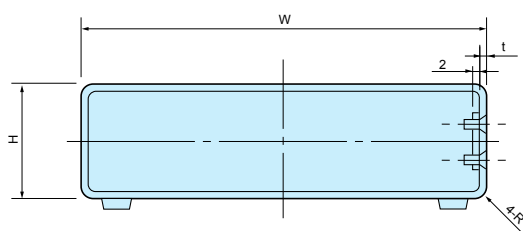

Color Type

Color code	Top · Bottom cover	Panel
AA	Ivory painted	Ivory painted
DD	Bronze anodized	Bronze anodized
GX	Dark gray painted	Light gray painted Dark gray painted

• GX type has mixed panel color. (1pcs of light gray, 1pcs of dark gray)

Part no. / Dimensions

• Please suffix color code at the end of part number □□ when ordering UC series.

Part no.	W	H	D	R	t	a	b	Ventilation hole	Weight (kg)
UC 6- 3- 8□□	60	35	80	5	2	16	58	—	0.12
UC 7- 3-10□□	75	30	100	5	2	16	78	—	0.16
UC 9- 5-12□□	90	50	120	7.5	2.5	18	94	—	0.29
UC10- 4-14□□	100	40	140	7.5	2.5	28	94	—	0.32
UC12- 7-16□□	120	70	160	11	3	30	110	—	0.56
UC13- 4-18□□	130	40	180	11	3	30	130	—	0.56
UC15- 8-20□□	150	80	200	11	3	30	150	○	0.86
UC16- 5-22□□	165	50	220	11	3	30	170	○	0.84
UC18-10-24□□	180	100	240	11	3	30	190	○	1.26
UC22-12-26□□	220	120	260	11	3	30	210	○	1.70
UC24-14-34□□	240	140	340	11.2	3.2	30	290	○	2.54
UC 8- 3- 6□□	80	30	60	5	2	16	38	—	0.10
UC11- 3- 8□□	110	30	80	5	2	16	58	—	0.17
UC11- 5- 8□□	110	50	80	5	2	16	58	—	0.20
UC14- 4-10□□	140	40	100	5	2	16	78	—	0.27
UC14- 6-10□□	140	60	100	5	2	16	78	—	0.31
UC15-10-12□□	150	100	120	7.5	2.5	18	94	—	0.53
UC17- 5-12□□	170	50	120	7.5	2.5	18	94	—	0.45
UC17- 7-12□□	170	70	120	7.5	2.5	18	94	—	0.51
UC20- 5-14□□	200	50	140	7.5	2.5	28	94	—	0.56
UC20- 8-14□□	200	80	140	7.5	2.5	28	94	—	0.67
UC20-12-16□□	200	120	160	11	3	30	110	—	0.82
UC26- 5-18□□	260	50	180	11	3	30	130	○	1.02
UC26-10-18□□	260	100	180	11	3	30	130	○	1.26
UC26- 7-20□□	260	70	200	11	3	30	150	○	1.23
UC32- 5-22□□	320	50	220	11	3	30	170	○	1.45
UC32-12-22□□	320	120	220	11	3	30	170	○	1.88
UC32- 8-24□□	320	80	240	11	3	30	190	○	1.76
UC35-13-26□□	350	130	260	11	3	30	210	○	2.45
UC43- 5-28□□	430	50	280	11	3	30	230	○	2.37
UC43-14-28□□	430	140	280	11	3	30	230	○	3.05
UC 7- 8-14□□	75	85	140	7.5	2.5	28	94	—	0.37
UC10-11-18□□	100	110	180	11	3	30	130	—	0.72
UC12-14-22□□	120	140	220	11	3	30	170	○	1.08
UC15-18-28□□	150	180	280	11	3	30	230	○	1.74
UC18-21-34□□	180	210	340	11.2	3.2	30	290	○	2.63

# UCC SERIES

## UCC MOUNTING PLATE FOR UC·UCY

• CAD data is downloadable from our website.

### Type A

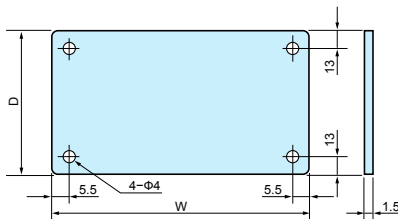
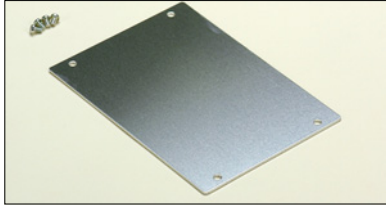

### Type B

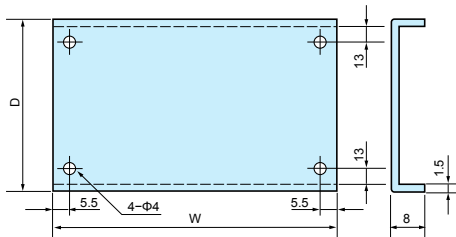
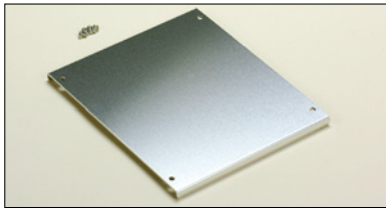

### Type C

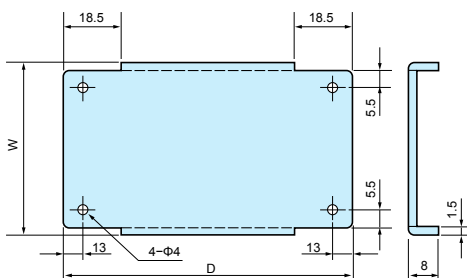

### Components

Part name	Material	Color / Finish
Mounting plate	Aluminium t1.5	Unfinished
Screw	Steel M3	Trivalent chromate

### Part no. / Dimensions (Type A)

Part no.	Suitable case	W	D
UCC 6- 8	UC 6- 3- 8	43	58
UCC 7-10	UC 7- 3-10	58	78
UCC 8- 6	UC 8- 3- 6	63	38
UCC11- 8	UC 11- 3- 8	93	58
	UC 11- 5- 8		
UCC 9-12	UC 9- 5-12	72	94
UCC10-14	UC 10- 4-14	82	94
UCC12-16	UC 12- 7-16	101	110
UCC13-18	UC 13- 4-18	111	130
UCC15-20	UC 15- 8-20	131	150
UCC14-10	UC 14- 4-10	123	78
	UC 14- 6-10		
UCC15-12	UC 15-10-12	132	94
UCC17-12	UC 17- 5-12	152	94
	UC 17- 7-12		
UCC 7-14	UC 7- 8-14	57	94
UCC10-18	UC 10-11-18	81	130
UCC12-22	UC 12-14-22	101	170
	UCY12-14-22		

### Part no. / Dimensions (Type B)

Part no.	Suitable case	W	D
UCC16-22	UC 16- 5-22	146	173
UCC18-24	UC 18-10-24	161	193
	UCY 18-10-24		
UCC20-14	UC 20- 5-14	182	97
	UC 20- 8-14		
UCC22-26	UC 22-12-26	201	213
UCC20-16	UC 20-12-16	181	113
UCC26-18	UC 26- 5-18	241	133
	UC 26-10-18		
UCC26-20	UC 26- 7-20	241	153
UCC32-22	UC 32- 5-22	301	173
	UC 32-12-22		
UCC32-24	UC 32- 8-24	301	193
UCC35-26	UC 35-13-26	331	213
UCC43-28	UC 43- 5-28	411	233
	UC 43-14-28		

### Part no. / Dimensions (Type C)

Part no.	Suitable case	W	D
UCC15-28	UC 15-18-28	134	230
	UCY15-18-28		
UCC18-34	UC 18-21-34	163.6	290
UCC24-34	UC 24-14-34	223.6	290

# UCK-P SERIES

## UCK-P MOUNTING BRACKET FOR UC·UCY

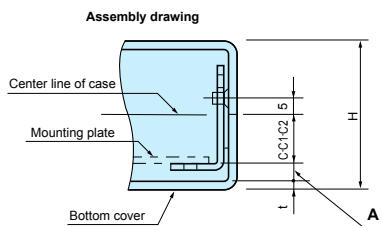
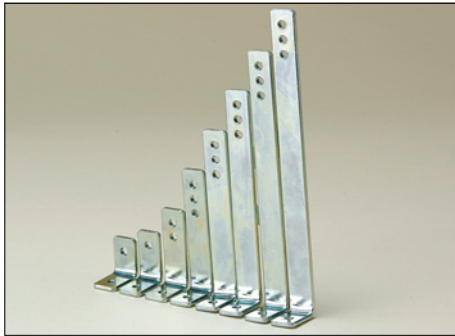

Components • CAD data is downloadable from our website.

Part name	Material	Finish	Sales unit
Mounting bracket	Steel t1.6	Trivalent chromate	4

### Part no. / Dimensions (1set = 4pcs)

Part no.	Type	H1	C	C1	C2
UCK-P 13	A	13	3	—	—
UCK-P 17	A	17	7	—	—
UCK-P 27	B	27	12	17	—
UCK-P 42	C	42	22	27	32
UCK-P 57	C	57	37	42	47
UCK-P 72	C	72	52	57	62
UCK-P 87	C	87	67	72	77
UCK-P102	C	102	82	87	92

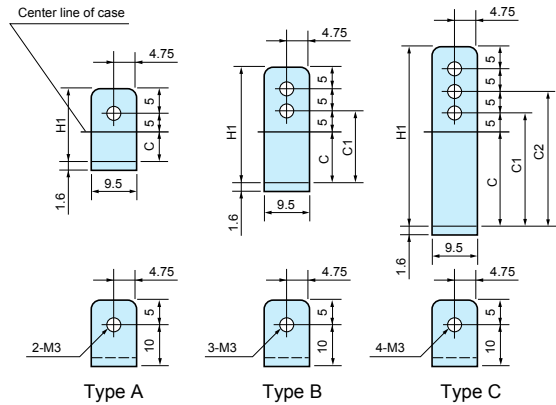

### Available mounting bracket

Case part No.	Bracket part No.	A dimension
UC 6- 3- 8	UCK-P 13	12.5
	UCK-P 17	8.5
UC 7- 3- 10	UCK-P 13	10
	UCK-P 17	6
UC 9- 5- 12	UCK-P 17	15.5
	UCK-P 27	10.5   5.5
UC 10- 4- 14	UCK-P 13	14.5
	UCK-P 17	10.5
	UCK-P 27	5.5
UC 12- 7- 16	UCK-P 27	15
	UCK-P 42	10
UC 13- 4- 18	UCK-P 13	14
	UCK-P 17	10
UC 15- 8- 20	UCK-P 42	15   10   5
UC 16- 5- 22	UCK-P 13	19
	UCK-P 17	15
	UCK-P 27	10
UC 24- 14- 34	UCK-P 57	19.8
	UCK-P 72	14.8   9.8
UC 8- 3- 6	UCK-P 13	10
	UCK-P 17	6
UC 11- 3- 8	UCK-P 13	10
	UCK-P 17	6
	UCK-P 17	6

Case part No.	Bracket part No.	A dimension
UC 11- 5- 8	UCK-P 17	16
	UCK-P 27	11   6
UC 14- 4- 10	UCK-P 13	15
	UCK-P 17	11
	UCK-P 27	6
UC 14- 6- 10	UCK-P 27	16   11
	UCK-P 42	6
UC 15- 10- 12	UCK-P 42	20.5   14.5
	UCK-P 57	10.5   5.5
UC 17- 5- 12	UCK-P 17	15.5
	UCK-P 27	10.5   5.5
UC 17- 7- 12	UCK-P 27	15.5
	UCK-P 42	10.5   5.5
UC 20- 5- 14	UCK-P 13	19.5
	UCK-P 17	15.5
	UCK-P 27	10.5   5.5
UC 20- 8- 14	UCK-P 27	20.5
	UCK-P 42	15.5   10.5
UC 20- 12- 16	UCK-P 57	20   15   10
UC 26- 5- 18	UCK-P 13	19
	UCK-P 17	15
	UCK-P 27	10
UC 26- 10- 18	UCK-P 42	20   15
	UCK-P 57	10

Case part No.	Bracket part No.	A dimension
UC 26- 7- 20	UCK-P 27	15
	UCK-P 42	10
UC 18- 10- 24	UCK-P 42	20   15
UCY 18- 10- 24	UCK-P 57	10
UC 22- 12- 26	UCK-P 57	20   15   10
UC 32- 5- 22	UCK-P 13	19
	UCK-P 17	15
	UCK-P 27	10
UC 32- 12- 22	UCK-P 57	20   15   10
UC 32- 8- 24	UCK-P 42	15   10   5
UC 35- 13- 26	UCK-P 57	25   20   15
	UCK-P 72	10   5
UC 43- 5- 28	UCK-P 13	19
	UCK-P 17	15
	UCK-P 27	10
UC 43- 14- 28	UCK-P 57	20
	UCK-P 72	15   10
UC 7- 8- 14	UCK-P 42	18   13   8
UC 10- 11- 18	UCK-P 57	15   10   5
UC 12- 14- 22	UCK-P 72	15   10   5
UCY 12- 14- 22	UCK-P 72	15   10   5
UC 15- 18- 28	UCK-P 87	20   15   10
UCY 15- 18- 28	UCK-P 87	20   15   10
UC 18- 21- 34	UCK-P102	19.8   14.8   9.8

## UCF PANEL RETAINER FOR UC·UCY

• Shock-proofed parts for panel.



### Assembly drawing

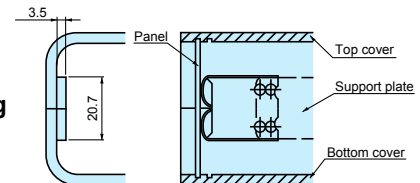

### Part no. / Dimensions (1set = 2pcs)

Part no. / Series	Material	Finish	Sales unit
UCF-26	Stainless steel t0.3	Unfinished	2

• Not used for 60, 80, 100, 120 of depth.

# MR · EM · EV SERIES

## MR TORX SCREW

### Head type

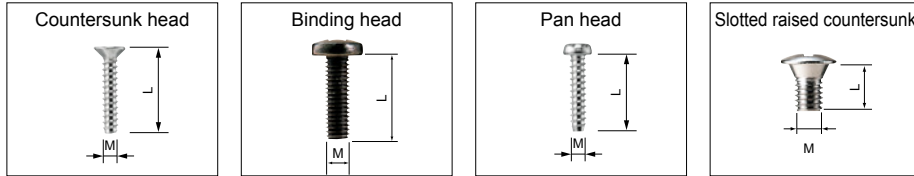

With pin



pin

★ Without pin



### Part no. / Dimensions ★Mark = Without pin

1pack = 20pcs

Part name	Part no.	M	L	Torx head no.	Material	Finish	Suitable enclosure
Countersunk head tapping screw	MR2.6 - 10S ★	2.6	10	T 8	Steel	Nickel plated	TW5-2-5 · 5-3-5 TW/TWN4-2-5 · 4-2-6 · 4-2-8 · 5-2-7 · 5-3-7 · 5-4-7 · 8-2-8 · 8-4-8
	MR2.6 - 10B ★	2.6	10	T 8	Steel	Black Cr3 chromate	TWF5-2-7 · 5-3-7 · 5-4-7 MX/MXA1-5-□ · 2-4-□ · 2-6-□ · 2-10-□
	MR2.6 - 14S	2.6	14	T 8	Steel	Nickel plated	TW/TWN7-2-11 · 7-4-11 · 7-5-11 LC115-N · F2 · F3
	MR2.6 - 18S	2.6	18	T 8	Steel	Nickel plated	LC115H-N · F2 · F3 · M2 · 9V LC135-N · F4 · M2 · M3 · 9V LC135H-N · F4 · M2 · M3 · 9V LC165/LC165H-N · M4
	MR3 - 14S ★	3	14	T10	Steel	Nickel plated	TW5-3-10 TW/TWN5-3-9 · 7-3-13 · 7-5-13 · 9-4-17 · 9-6-17
	MR3 - 14B ★	3	14	T10	Steel	Black Cr3 chromate	TWF7-3-13 · 7-5-13 · 9-4-17 · 9-6-17 MX4-7-□ · 4-10-□ · 4-13-□
Countersunk head screw	MR - 1S	3	5	T10	Steel	Nickel plated	UC
	MR - 1B	3	5	T10	Steel	Black Cr3 chromate	UC
	MR - 2S	3	10	T10	Steel	Nickel plated	HEN
Binding head screw	MR2.5 - 8ST	2.5	8	T 8	SUS	Unfinished	WP9-13-3 · 10-10-3 · 11-15-3
	MR2.5 - 16ST	2.5	16	T 8	SUS	Unfinished	WP9-13-4 · 10-10-4 · 11-15-4
Pan head tapping screw	MR1.6 - 6S ★	1.6	6	T 3	Steel	Nickel plated	CSS · CS
	MR2.5 - 8PS	2.5	8	T 8	Steel	Nickel plated	PF15-3-10 · 15-5-10 · 15-3-15 · 15-5-15
	MR2.6 - 12PS	2.6	12	T 8	Steel	Nickel plated	LC115-F2 · F3
	MR2.6 - 14PS	2.6	14	T 8	Steel	Nickel plated	LC115H-F2 · F3 · M2 · 9V LC135-F4 · M2 · M3 · 9V LC135H-F4 · M2 · M3 · 9V LC165/LC165H-N · M4
	MR3 - 8PS	3	8	T10	Steel	Nickel plated	PF20-4-13 · 20-6-13 · 20-4-20 · 20-6-20
Slotted raised countersunk screw	MR3 - 5ZS	3	5	T10	Steel	Nickel plated	CH · CF · FC · FCH · HS · HY · HYR
	MR3 - 5ZB	3	5	T10	Steel	Black Cr3 chromate	