

REV.	DESCRIPTION	DATE	APPROVED
A	Engineering Release	07/31/15	J. C.

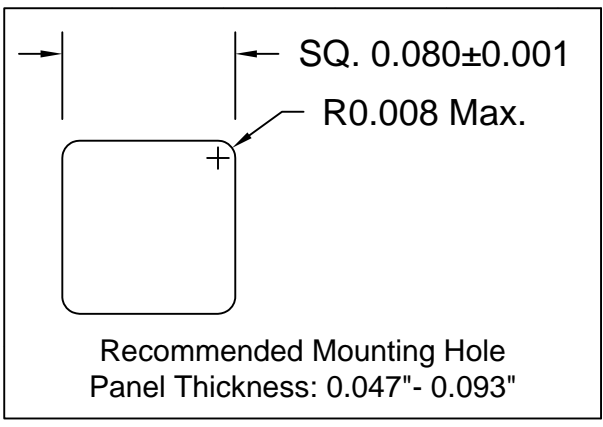

Part No.	X = Body Length
PLPQ2-100-FF	0.100 ( 2.5mm )
PLPQ2-125-FF	0.125 ( 3.2mm )
PLPQ2-188-FF	0.188 ( 4.8mm )
PLPQ2-250-FF	0.250 ( 6.4mm )
PLPQ2-313-FF	0.313 ( 7.9mm )
PLPQ2-375-FF	0.375 ( 9.5mm )
PLPQ2-500-FF	0.500 ( 12.7mm )
PLPQ2-3MM-FF	3mm ( 0.118" )
PLPQ2-4MM-FF	4mm ( 0.157" )
PLPQ2-5MM-FF	5mm ( 0.197" )
PLPQ2-6MM-FF	6mm ( 0.236" )
PLPQ2-7MM-FF	7mm ( 0.276" )
PLPQ2-8MM-FF	8mm ( 0.315" )
PLPQ2-9MM-FF	9mm ( 0.354" )
PLPQ2-10MM-FF	10mm ( 0.394" )

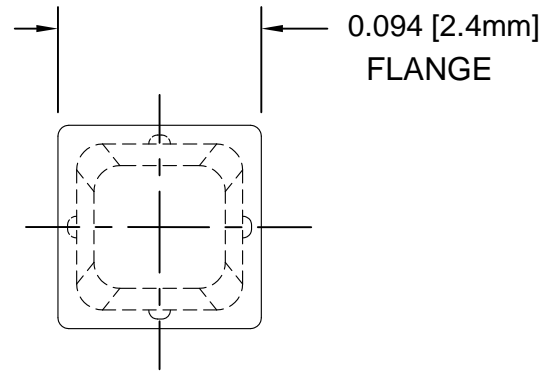
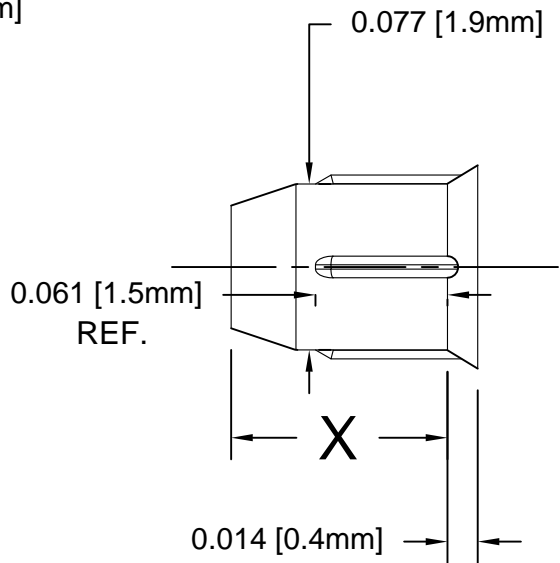
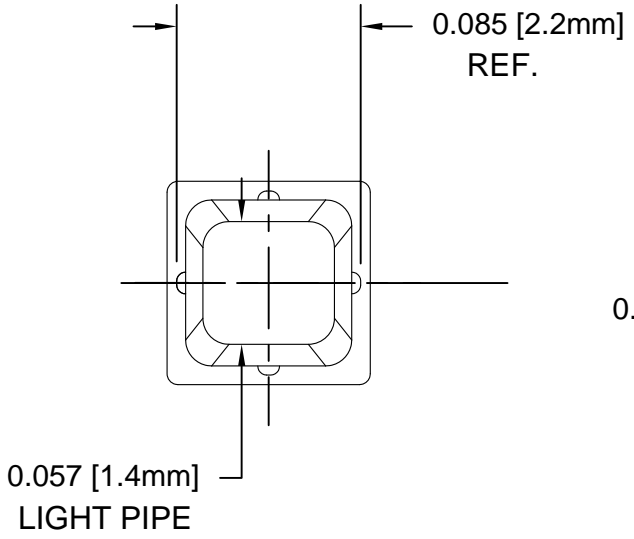
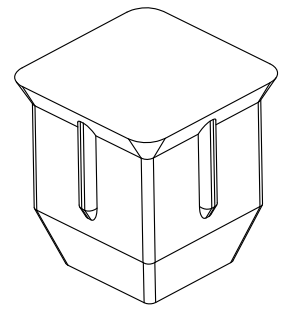

STANDARD TOLERANCE ( UNLESS OTHERWISE SPECIFIED )		 4 THOMAS, IRVINE, CA. 92618 TEL: (949) 951-8808 FAX: (949) 951-3974	
.X ± .1	ANGULAR X° ± 1°		
.XX ± .01		<b>TITLE:</b> SQUARE LIGHT PIPE, FLUSH MOUNT, 2mm	
.XXX ± .005			
DESIGNED: <b>Brian Oliver</b>	DATE: <b>04/24/15</b>	<b>PART NO:</b> PLPQ2-XXX-FF	REVISION: <b>A</b>
CHECKED: <b>Alex Wright</b>	DATE: <b>04/24/15</b>		<b>CAGE CODE :</b> 32559
CAD GENERATED DOCUMENT. DO NOT MEASURE DRAWING.			

- 2. MATERIAL: POLYCARBONATE, 94V-0, CLEAR
- 1. GENERAL SPECIFICATIONS: BIVAR MOLDED COMPONENT SPECIFICATION BV00-E101 and BSMC-1001.