



# DSC150X/DSC152X

## Low-Power Low-Jitter MEMS Oscillators

### Features

- Any Frequency Between:
  - 2.3 MHz to 170 MHz (2.5V and 3.3V)
  - 2.3 MHz to 125 MHz (1.8V)
- Exceptional Total Stability Over Temperature  
±20 ppm, ±25 ppm, ±50 ppm
- Low Phase Jitter (1 ps Typical)
- Operating Voltage 1.8V/2.5V to 3.3V
- Standby Mode for Battery Life Saving
- Fast Startup Time (2.5 ms Typical)
- Extended Temperature Range: -40°C to +125°C
- For AEC-Q Qualified, refer to DSA150x/DSA152x Product Family
- Low Operation Current (6.5 mA Typical)
- Ultra-Small Footprints:
  - 2.0 mm × 1.6 mm VFLGA Package
  - 2.5 mm × 2.0 mm VLGA Package
  - 3.2 mm × 2.5 mm VDFN Package
  - 5.0 mm × 3.2 mm VDFN Package
  - 7.0 mm × 5.0 mm VDFN Package
- High Reliability: 20× Better MTF than Quartz Oscillators
- MIL-STD 883 Shock and Vibration Resistant
- Lead-Free and RoHS-Compliant

### Applications

- USB, SATA, SAS Reference Clock
- 100M/1G/10G Ethernet Clock
- IP Cam, DVR, OTT-Box
- Storage/SSD
- IoT Terminal/Gateway

### Benefits

- Pin for Pin “Drop-In” Replacement for Industry Standard Oscillators
- Semiconductor-Level Reliability, Significantly Higher than Quartz
- Short Production Lead Time
- Longer Battery Life/Reduced Power Consumption
- Compact Plastic Package
- Cost Effective

### General Description

The DSC1501/2/3/4/5 and DSC1521/2/3/4/5 are industry-leading MEMS oscillators that offer excellent jitter and stability performance at very low power over a wide range of supply voltage (1.71V to 3.63V) and temperature (-40°C to +125°C). The devices operate from 2.3 MHz to 170 MHz with 2.5V and 3.3V supply voltage and from 2.3 MHz to 125 MHz with 1.8V supply voltage.

The devices incorporate an all-silicon resonator that is extremely robust. A MEMS-based design allows for a higher level of reliability, making the DSC150x/DSC152x ideal for rugged, industrial, and portable applications where stress, shock, and vibrations can damage quartz crystal-based systems. The devices are also an excellent choice as clock reference for small, battery-operated devices, such as wearables and Internet-of-Things (IoT) devices.

Available in industry standard packages, the DSC150x/DSC152x can be a drop-in replacement to standard crystal oscillators.

### Package Type

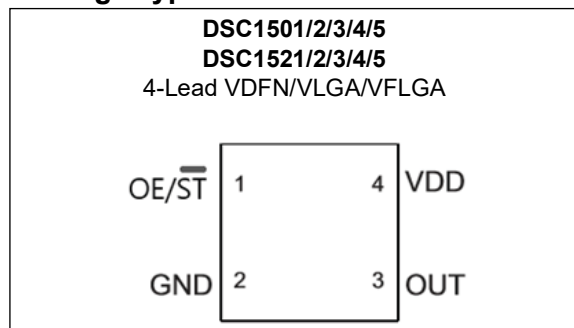

# DSC150X/DSC152X

Functional Block Diagram

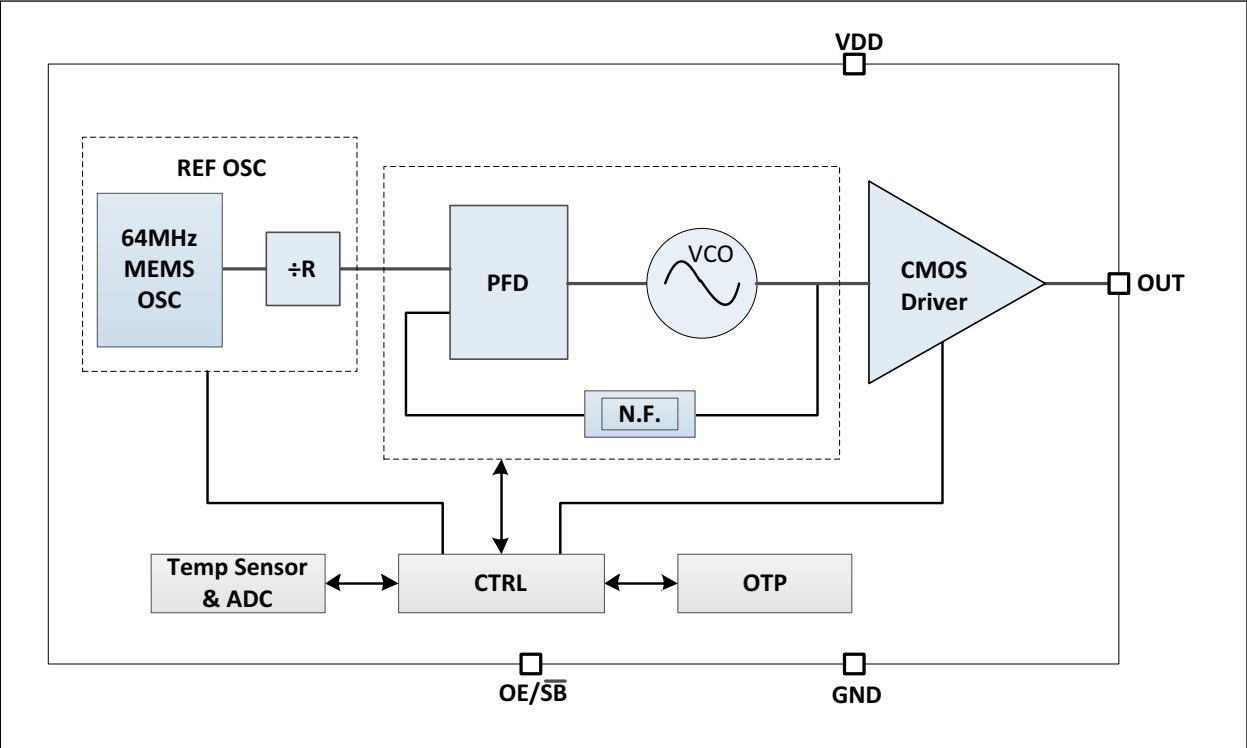

**Note:** N.F. stands for iNteger/Fractional dividers.

# DSC150X/DSC152X

## 1.0 ELECTRICAL CHARACTERISTICS

### Absolute Maximum Ratings † ††

Supply Voltage ( $V_{CC}$ ).....	-0.3V to +4.0V
LVTTL Input Voltage.....	-0.3V to $V_{DD} + 0.3V$
ESD Protection (HBM).....	4 kV
ESD Protection (MM).....	400V
ESD Protection (CDM).....	2 kV

† **Notice:** Stresses above those listed under “Absolute Maximum Ratings” may cause permanent damage to the device. This is a stress rating only and functional operation of the device at those or any other conditions above those indicated in the operational sections of this specification is not intended. Exposure to maximum rating conditions for extended periods may affect device reliability.

†† **Notice:** The data sheet limits are not guaranteed if the device is operated beyond the recommended operating conditions.

### ELECTRICAL CHARACTERISTICS

**Electrical Characteristics:**  $V_{DD} = 1.8V +10\%/ -5\%$ ,  $V_{DD} = 2.5V \pm 10\%$ ,  $V_{DD} = 3.3V \pm 10\%$ ;  $T_A = -40^\circ C$  to  $+125^\circ C$ , unless noted.

Parameter	Symbol	Min.	Typ.	Max.	Units	Conditions	
Supply Voltage	$V_{DD}$	2.25	—	3.63	V	Note 1, DSC1501/2/3, DSC1521/2/3	
		1.71	—	1.98		Note 1, DSC1504/5, DSC1524/5	
Power Supply Ramp	$t_{PU}$	0.1	—	100	ms	Note 2	
Supply Current	$I_{DD}$	—	6.5	7.5	mA	$f_0 = 20$ MHz, $V_{DD} = 3.3V$ , no load, output enabled	
		—	6.5	7.8		$f_0 = 141.249$ MHz, $V_{DD} = 3.3V$ , no load, output disabled	
Standby Current	$I_{STDBY\_}$	—	1	—	$\mu A$	$V_{DD} = 1.8V/2.5V$	
		—	1.8	—		$V_{DD} = 3.3V$	
Input Logic Levels	$V_{IH}$	$0.7 \times V_{DD}$	—	—	V	Input logic High, Note 3	
	$V_{IL}$	—	—	$0.3 \times V_{DD}$		Input logic Low, Note 3	
Output Logic Levels	$V_{OH}$	$0.8 \times V_{DD}$	—	—	V	$V_{DD} = 3.3V$	$I_{OH} = -16$ mA, Std. drive
			—	—			$I_{OH} = -12$ mA, Medium drive
			—	—			$I_{OH} = -6$ mA, Low drive
			—	—	$V_{DD} = 2.5V$	$I_{OH} = -10$ mA, Std. drive	
			—	—		$I_{OH} = -6$ mA, Medium drive	
			—	—		$I_{OH} = -3$ mA, Low drive	
			—	—	$V_{DD} = 1.8V$	$I_{OH} = -4$ mA, Standard drive	
			—	—		$I_{OH} = -2$ mA, Low drive	
Output Logic Levels	$V_{OL}$	$0.2 \times V_{DD}$	—	—	V	$V_{DD} = 3.3V$	$I_{OL} = 16$ mA, Standard drive
			—	—			$I_{OL} = 12$ mA, Medium drive
			—	—			$I_{OL} = 6$ mA, Low drive
			—	—	$V_{DD} = 2.5V$	$I_{OL} = 10$ mA, Standard drive	
			—	—		$I_{OL} = 6$ mA, Medium drive	
			—	—		$I_{OL} = 3$ mA, Low drive	
			—	—	$V_{DD} = 1.8V$	$I_{OL} = 4$ mA, Standard drive	
			—	—		$I_{OL} = 2$ mA, Low drive	
Output Duty Cycle	—	47	—	53	%	—	

# DSC150X/DSC152X

## ELECTRICAL CHARACTERISTICS (CONTINUED)

**Electrical Characteristics:**  $V_{DD} = 1.8V \pm 10\%/-5\%$ ,  $V_{DD} = 2.5V \pm 10\%$ ,  $V_{DD} = 3.3V \pm 10\%$ ;  $T_A = -40^\circ C$  to  $+125^\circ C$ , unless noted.

Parameter	Symbol	Min.	Typ.	Max.	Units	Conditions
Frequency	$f_0$	2.3	—	170	MHz	Standard drive $V_{DD} = 3.3V$ and $V_{DD} = 2.5V$
		2.3	—	125		Medium drive
		2.3	—	50		Low drive
		2.3	—	125	MHz	Standard drive $V_{DD} = 1.8V$
		2.3	—	60		Low drive
Frequency Stability	$\Delta f$	—	$\pm 20$	—	ppm	Includes frequency variations due to initial tolerance, temperature and power supply voltage.
		—	$\pm 25$	—		
		—	$\pm 50$	—		
Aging	$\Delta f$	—	$\pm 5$	—	ppm	First year @ $25^\circ C$
		—	$\pm 1$	—		Per year after first year
Startup Time	$t_{SU}$	—	2.5	—	ms	From 90% $V_{DD}$ until the output starts toggling
Output Disable Time	$t_{ODS}$	—	15	—	ns	From OE toggle to output OFF
Output Enable Time	$t_{ENOE}$	—	—	1	$\mu s$	Pin 1 configured as OE
	$t_{ENST}$	—	—	2	ms	Pin 1 configured as Standby
Enable Pull-up Resistor	—	70	—	—	k $\Omega$	Pull-up resistor at pin 1
Output Transition Time	$t_R/t_F$	—	1.4/1.3	—	ns	$V_{DD} = 1.8V$ DSC1505, Std drive 20%-80%, $C_L = 10$ pF
		—	1.1/1.0	—		$V_{DD} = 2.5V$ DSC1502, Std drive
		—	1.2/1.0	—		$V_{DD} = 3.3V$ 20%-80%, $C_L = 10$ pF
		—	3.0/2.4	—		$V_{DD} = 1.8V$ DSC1504, Low drive 20%-80%, $C_L = 10$ pF
		—	1.9/1.7	—		$V_{DD} = 2.5V$ DSC1501, Med drive
		—	1.4/1.1	—		$V_{DD} = 3.3V$ 20%-80%, $C_L = 10$ pF
		—	4.5/4.1	—		$V_{DD} = 2.5V$ DSC1503, Low drive
		—	3.4/2.9	—		$V_{DD} = 3.3V$ 20%-80%, $C_L = 10$ pF
Cycle-to-Cycle Jitter (Peak)	$J_{CC}$	—	40	—	ps	$f_{OUT} = 25$ MHz
		—	18	—		
		—	15	—		
Period Jitter, RMS	$J_{PER}$	—	6	—	ps	$f_{OUT} = 25$ MHz
		—	2.5	—		
		—	2.5	—		
Period Jitter (Peak-to-Peak)	$J_{PP}$	—	45	—	ps	$f_{OUT} = 25$ MHz
		—	20	—		
		—	18	—		
Integrated Phase Noise	$J_{PH}$	—	1	—	ps <sub>RMS</sub>	$f_{OUT} = 100$ MHz 12 kHz to 20 MHz, $V_{DD} = 3.3V$

**Note 1:**  $V_{DD}$  pin should be filtered with a 0.1  $\mu F$  capacitor.

**Note 2:** Time to reach 90% of target  $V_{DD}$ . Power ramp must be monotonic.

**Note 3:** Input waveform must be monotonic with rise/fall time < 10 ms.

## TEMPERATURE SPECIFICATIONS (Note 1)

Parameters	Symbol	Min.	Typ.	Max.	Units	Conditions
<b>Temperature Ranges</b>						
Operating Ambient Temperature Range	$T_A$	-40	—	+125	°C	—
Maximum Junction Temperature	$T_J$	—	—	+125	°C	—
Storage Temperature Range	$T_S$	-55	—	+150	°C	—
Lead Temperature	—	—	+260		°C	Soldering, 20 sec.

**Note 1:** The maximum allowable power dissipation is a function of ambient temperature, the maximum allowable junction temperature and the thermal resistance from junction to air (i.e.,  $T_A$ ,  $T_J$ ,  $\theta_{JA}$ ). Exceeding the maximum allowable power dissipation will cause the device operating junction temperature to exceed the maximum +125°C rating. Sustained junction temperatures above +125°C can impact the device reliability.

# DSC150X/DSC152X

---

## 2.0 PIN DESCRIPTIONS

The descriptions of the pins are listed in [Table 2-1](#).

**TABLE 2-1: PIN FUNCTION TABLE**

Pin Number	Pin Name	Description
1	OE	Output Enabled: H = Output buffer Enabled, L = Disabled (High impedance): External pull-up recommended for normal operation.
	$\overline{\text{STB}}$	Standby: H = Device is active, L = Device is in Standby (Both output buffer and PLL disabled): External pull-up recommended for normal operation.
2	GND	Ground
3	OUT	Oscillator clock output
4	VDD	Power Supply: 1.71V to 3.63V

## 3.0 TYPICAL PHASE NOISE PLOT

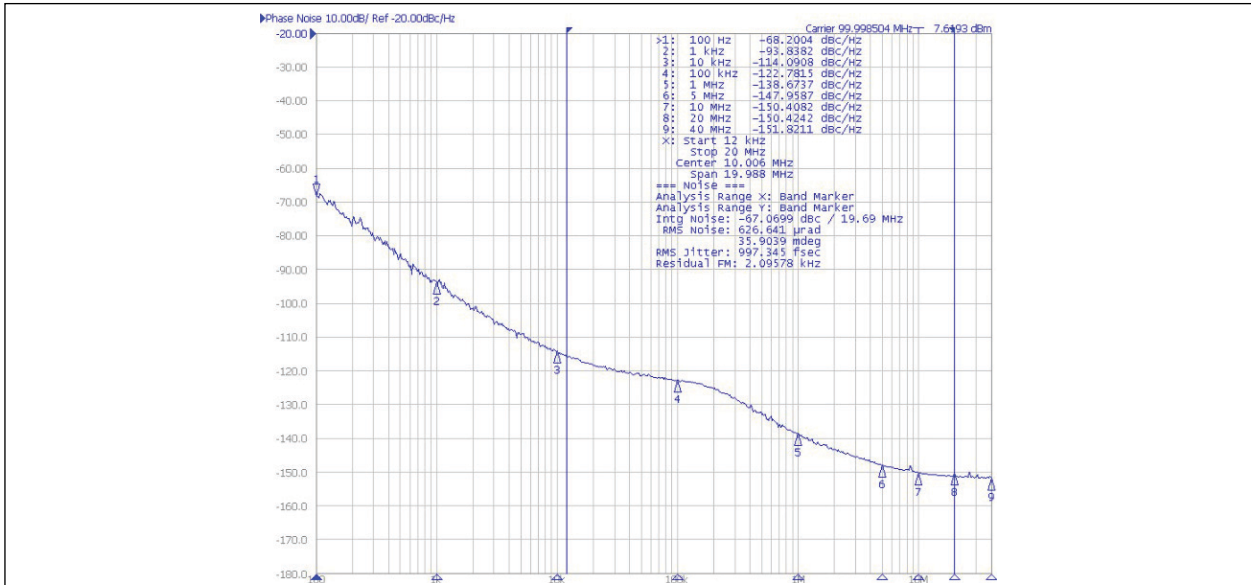

FIGURE 3-1: Typical Phase Noise @ 25°C, 100 MHz, 3.3V.

## 4.0 OUTPUT WAVEFORM

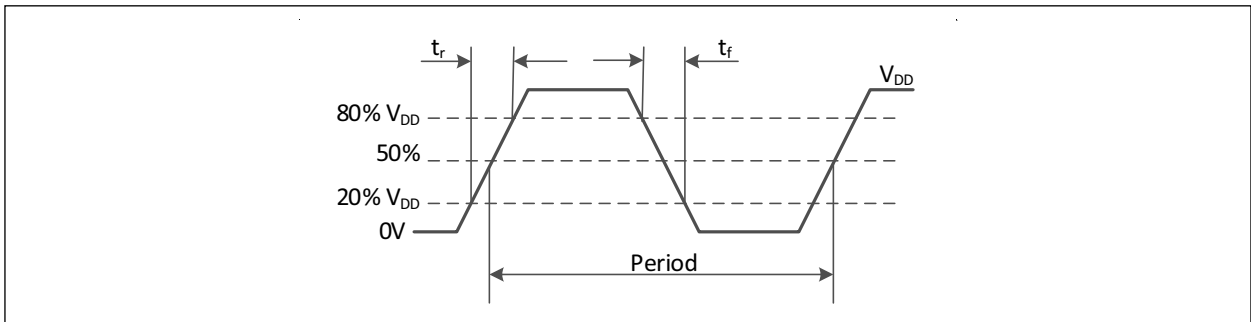

FIGURE 4-1: Output Waveform.

## 5.0 TEST CIRCUIT

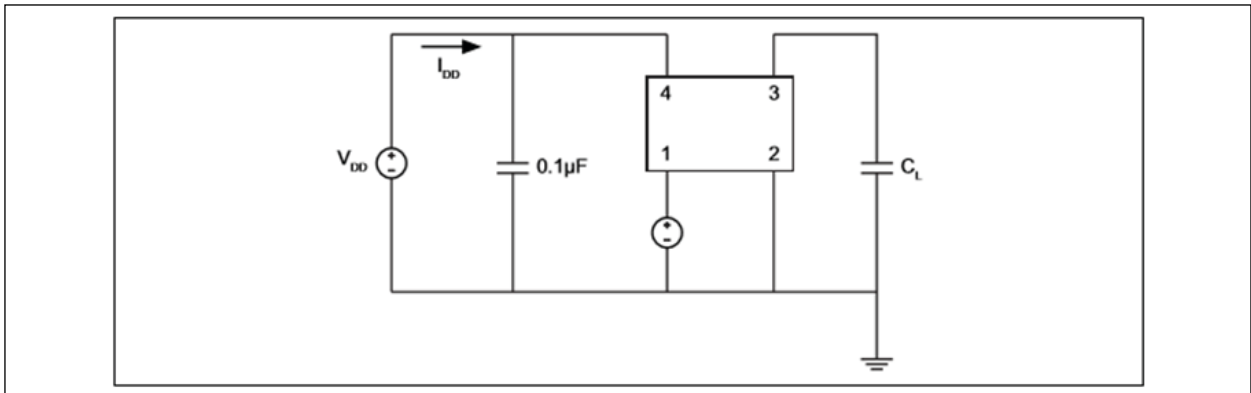
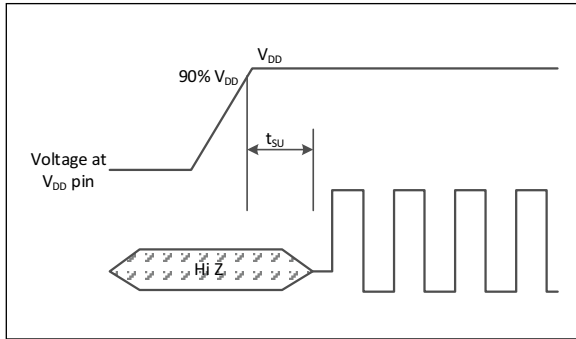

FIGURE 5-1: Test Circuit.

# DSC150X/DSC152X

## 6.0 TIMING DIAGRAMS



**FIGURE 6-1:** Start-Up Time.

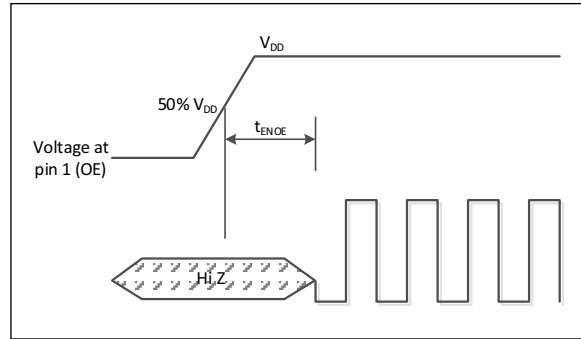

**FIGURE 6-3:** Enable Time with Pin 1 Configured as OE.

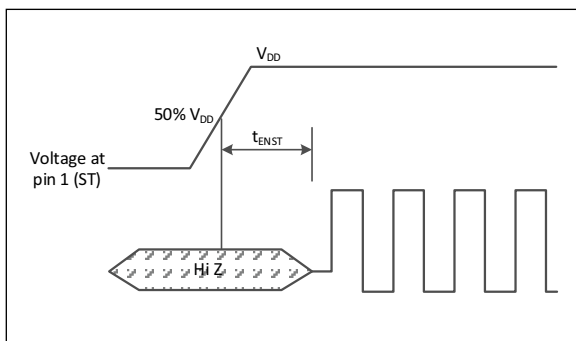

**FIGURE 6-2:** Enable Time with Pin 1 Configured as Standby (STB).

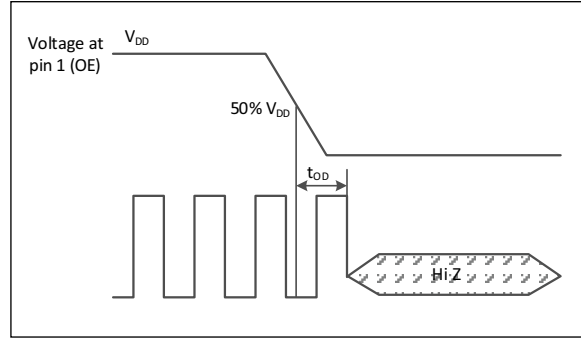

**FIGURE 6-4:** Disable Time with Pin 1 Configured as OE.

As shown, the output Enable/Disable in OE mode (pin 1 configured as OE) happens at the clock falling edge while in Standby mode (pin 1 configured as STB) it happens asynchronously.

## 7.0 SOLDER REFLOW PROFILE

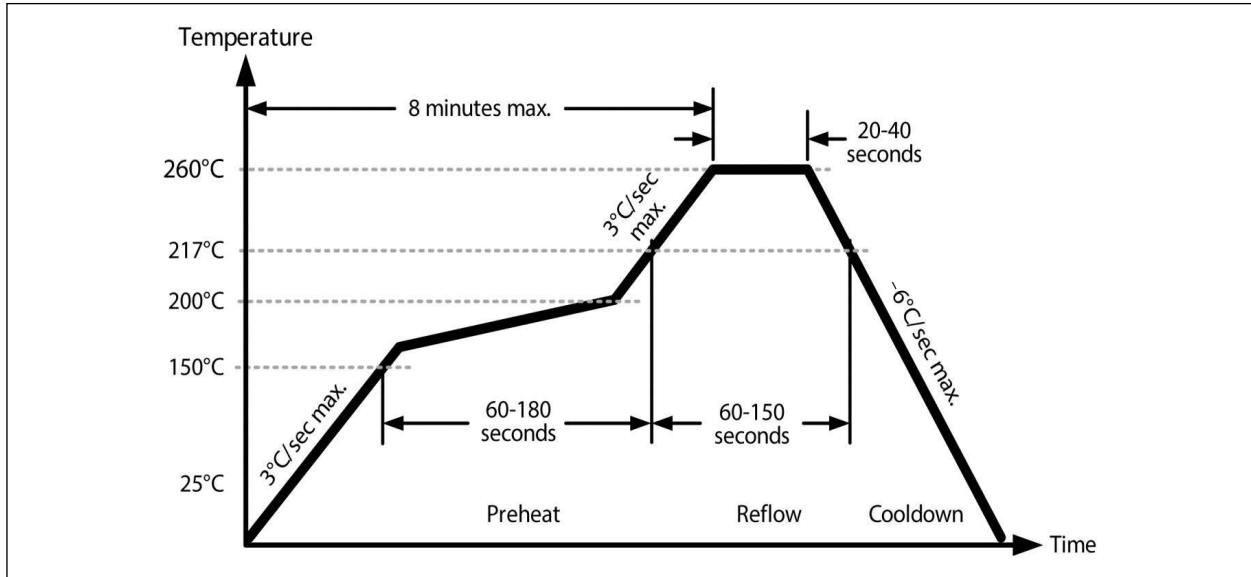

**FIGURE 7-1:** Solder Reflow Profile.

**TABLE 7-1: SOLDER REFLOW**

MSL 1 @ 250°C Refer to JSTD-020C	
Ramp-Up Rate (200°C to Peak Temp.)	3°C/sec. max.
Preheat Time 150°C to 200°C	60 to 180 sec.
Time Maintained above 217°C	60 to 150 sec.
Peak Temperature	255°C to 260°C
Time within 5°C of Actual Peak	20 to 40 sec.
Ramp-Down Rate	-6°C/sec. max.
Time 25°C to Peak Temperature	8 minutes max.

# DSC150X/DSC152X

## 8.0 FUNCTIONAL DESCRIPTION

The DSC150x/DSC152x are MEMS-based CMOS oscillators that combine excellent jitter and stability performance at a very low power over a wide range of supply voltage and temperature. The device operates from 2.3 MHz to 170 MHz with 2.5V and 3.3V supply voltage and from 2.3 MHz to 125 MHz with 1.8V supply voltage over  $-40^{\circ}\text{C}$  to  $+125^{\circ}\text{C}$  temperature range. It has four pins and comes in different industry-standard package sizes.

The standard DSC150x/DSC152x comes with standard output drive strength with optional low and high drive strengths (see [Table 8-1](#)). Low output drive strength offers slower edge rates for lower EMI interference.

**TABLE 8-1: OUTPUT DRIVE STRENGTH**

Device	CMOS Output Strength
DSC1501/21	LVC MOS Medium drive (2.5V/3.3V)
DSC1502/22	LVC MOS Standard drive (2.5V/3.3V)
DSC1503/23	LVC MOS Low drive (2.5V/3.3V)
DSC1504/24	LVC MOS Low drive (1.8V)
DSC1505/25	LVC MOS Standard drive (1.8V)

Pin 1 can be programmed to implement Enable function (OE) or Standby function (STB).

**TABLE 8-2: ENABLE AND STANDBY FUNCTION**

Control Pin (Pin 1) Definition			
P/N	Function	Pin 1 High	Pin 1 Low
DSC150x	Standby	Active	Standby
DSC152x	Enable/Disable	Enable	Disable

Users can build the part with their desired output drive strength and pin 1 control pin options by using the ClockWorks Configurator online tool.

## 9.0 RECOMMENDED BOARD LAYOUT

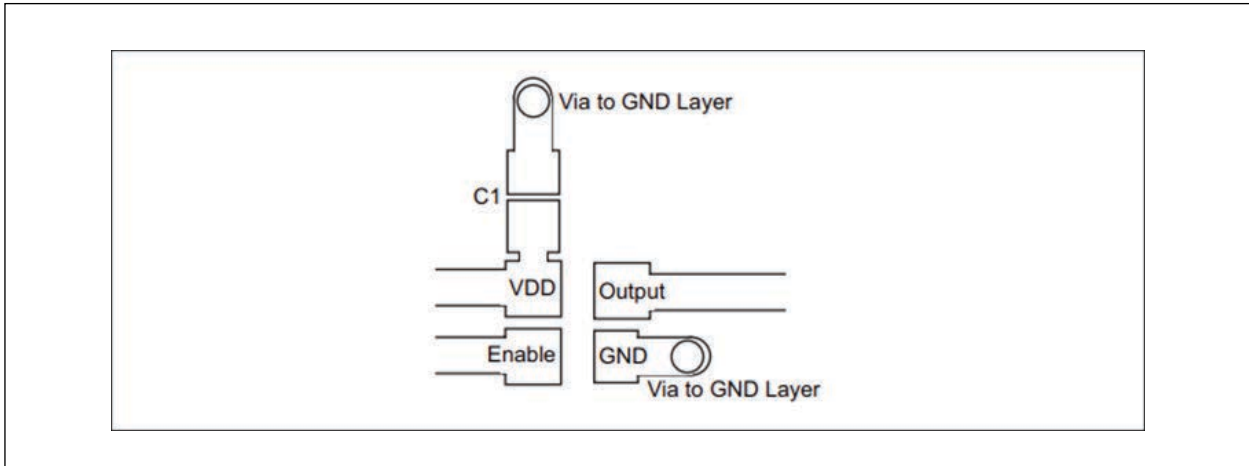

**FIGURE 9-1:** Recommended Board Layout.

# DSC150X/DSC152X

## 10.0 PACKAGING INFORMATION

### 10.1 Package Marking Information

4-Lead LGA/DFN\*  
2.5 × 2.0 through 7.0 × 5.0 (in mm)

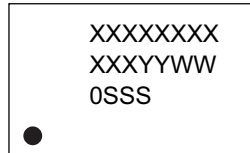

Example 1

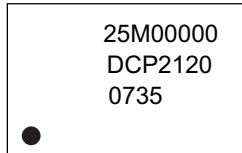

Example 2

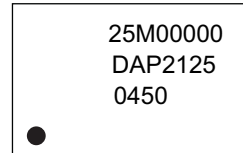

2.0 mm × 1.6 mm

Example

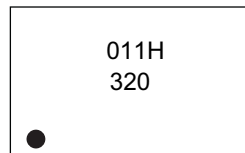

<b>Legend:</b>	XX...X	Product code or customer-specific information
	Y	Year code (last digit of calendar year)
	YY	Year code (last 2 digits of calendar year)
	WW	Week code (week of January 1 is week '01')
	SSS	Alphanumeric traceability code
	(e3)	Pb-free JEDEC® designator for Matte Tin (Sn)
	*	This package is Pb-free. The Pb-free JEDEC designator ((e3)) can be found on the outer packaging for this package.
	•, ▲, ▼	Pin one index is identified by a dot, delta up, or delta down (triangle mark).
<b>Note:</b>	In the event the full Microchip part number cannot be marked on one line, it will be carried over to the next line, thus limiting the number of available characters for customer-specific information. Package may or may not include the corporate logo.	
	Underbar (¯) and/or Overbar (¯) symbol may not be to scale.	

# DSC150X/DSC152X

## 4-Lead 2.0 mm × 1.6 mm Very Thin Fine Pitch Land Grid Array (VFLGA) Package Outline and Recommended Land Pattern [ASA]

**Note:** For the most current package drawings, please see the Microchip Packaging Specification located at <http://www.microchip.com/packaging>

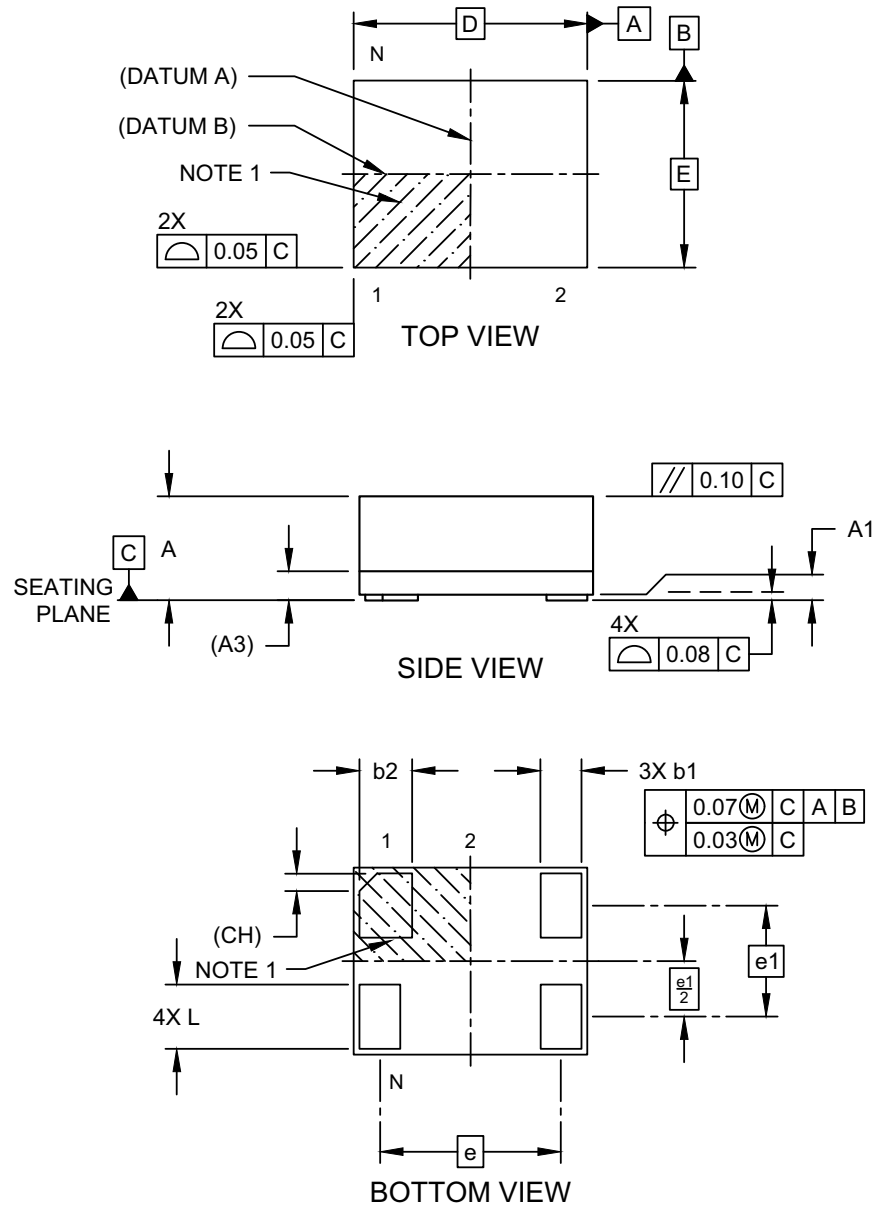

Microchip Technology Drawing C04-1200-ASA Rev E Sheet 1 of 2

# DSC150X/DSC152X

## 4-Lead 2.0 mm × 1.6 mm Very Thin Fine Pitch Land Grid Array (VFLGA) Package Outline and Recommended Land Pattern [ASA]

**Note:** For the most current package drawings, please see the Microchip Packaging Specification located at <http://www.microchip.com/packaging>

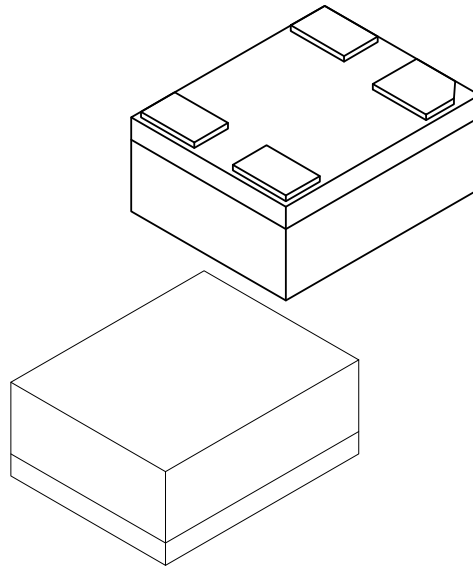

Dimension Limits	Units	MILLIMETERS		
		MIN	NOM	MAX
Number of Terminals	N	4		
Terminal Pitch	e	1.55 BSC		
Terminal Pitch	e1	0.95 BSC		
Overall Height	A	0.79	0.84	0.89
Standoff	A1	0.00	0.02	0.05
Substrate Thickness (with Terminals)	A3	0.20 REF		
Overall Length	D	2.00 BSC		
Overall Width	E	1.60 BSC		
Terminal Width	b1	0.30	0.35	0.40
Terminal Width	b2	0.40	0.45	0.50
Terminal Length	L	0.50	0.55	0.60
Terminal 1 Index Chamfer	CH	-	0.15	-

**Notes:**

1. Pin 1 visual index feature may vary, but must be located within the hatched area.
2. Package is saw singulated
3. Dimensioning and tolerancing per ASME Y14.5M  
BSC: Basic Dimension. Theoretically exact value shown without tolerances.  
REF: Reference Dimension, usually without tolerance, for information purposes only.

Microchip Technology Drawing C04-1200-ASA Rev E Sheet 2 of 2

## 4-Lead 2.0 mm × 1.6 mm Very Thin Fine Pitch Land Grid Array (VFLGA) Package Outline and Recommended Land Pattern [ASA]

**Note:** For the most current package drawings, please see the Microchip Packaging Specification located at <http://www.microchip.com/packaging>

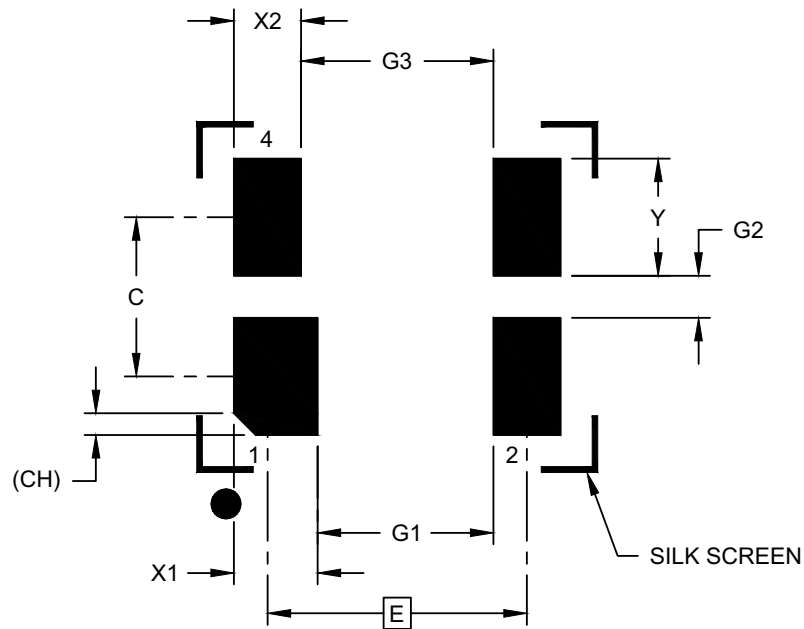

### RECOMMENDED LAND PATTERN

Dimension Limits	Units	MILLIMETERS		
		MIN	NOM	MAX
Contact Pitch	E	1.55 BSC		
Contact Spacing	C		0.95	
Contact Width (X1)	X1			0.50
Contact Width (X3)	X2			0.40
Contact Pad Length (X4)	Y			0.70
Space Between Contacts	G1	1.05		
Space Between Contacts	G2	0.25		
Space Between Contacts	G3	1.15		
Contact 1 Index Chamfer	CH	0.13 X 45° REF		

**Notes:**

1. Dimensioning and tolerancing per ASME Y14.5M

BSC: Basic Dimension. Theoretically exact value shown without tolerances.

Microchip Technology Drawing C04-3200-ASA Rev E

# DSC150X/DSC152X

## 4-Lead 2.5 mm × 2.0 mm Very Thin Land Grid Array (VLGA) Package Outline and Recommended Land Pattern [AUA]

**Note:** For the most current package drawings, please see the Microchip Packaging Specification located at <http://www.microchip.com/packaging>

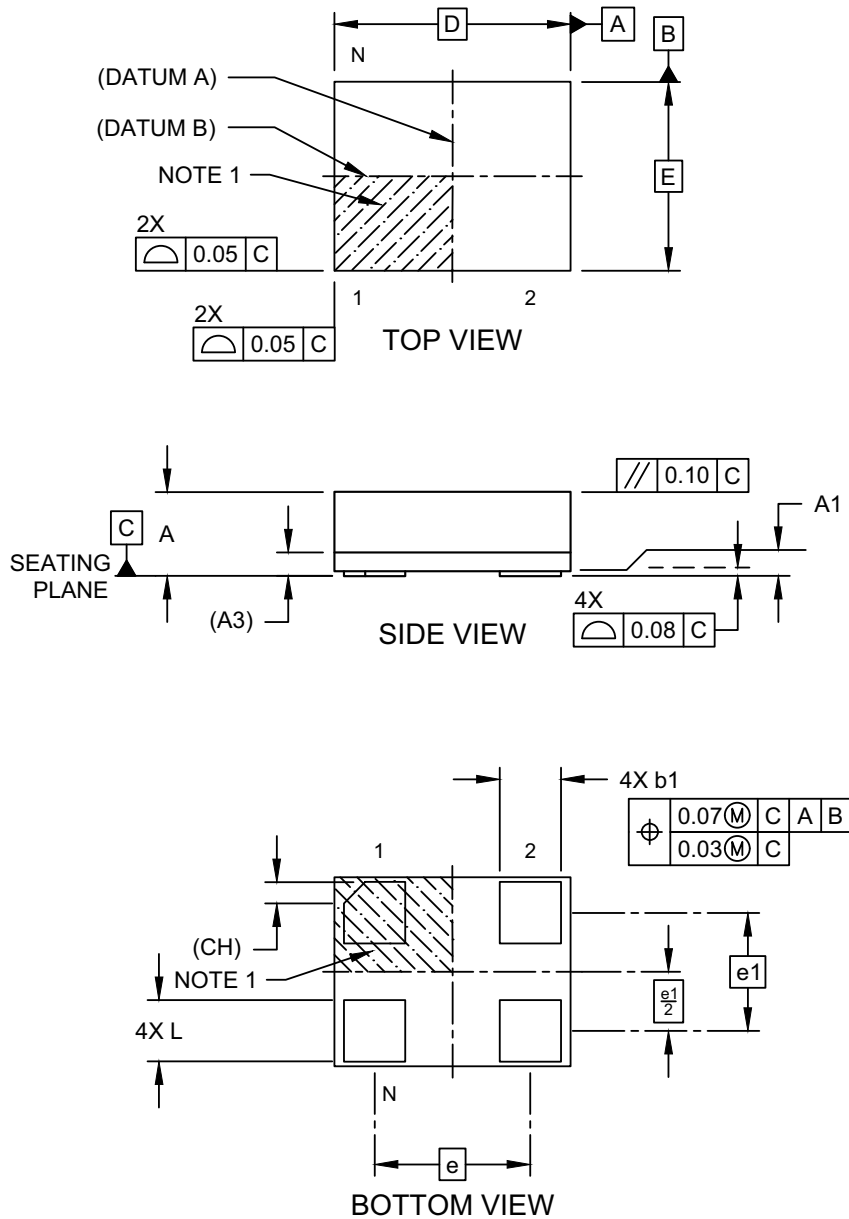

Microchip Technology Drawing C04-1202-AUA Rev C Sheet 1 of 2

## 4-Lead 2.5 mm × 2.0 mm Very Thin Land Grid Array (VLGA) Package Outline and Recommended Land Pattern [AUA]

**Note:** For the most current package drawings, please see the Microchip Packaging Specification located at <http://www.microchip.com/packaging>

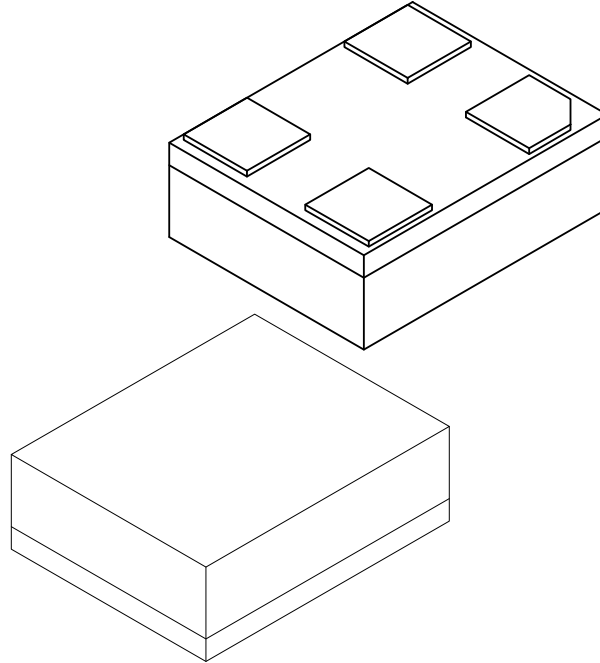

Dimension Limits	Units	MILLIMETERS		
		MIN	NOM	MAX
Number of Terminals	N	4		
Terminal Pitch	e	1.65 BSC		
Terminal Pitch	e1	1.25 BSC		
Overall Height	A	0.79	0.84	0.89
Standoff	A1	0.00	0.02	0.05
Substrate Thickness (with Terminals)	A3	0.20 REF		
Overall Length	D	2.50 BSC		
Overall Width	E	2.00 BSC		
Terminal Width	b1	0.60	0.65	0.70
Terminal Length	L	0.60	0.65	0.70
Terminal 1 Index Chamfer	CH	-	0.225	-

**Notes:**

- Pin 1 visual index feature may vary, but must be located within the hatched area.
- Package is saw singulated
- Dimensioning and tolerancing per ASME Y14.5M
  - BSC: Basic Dimension. Theoretically exact value shown without tolerances.
  - REF: Reference Dimension, usually without tolerance, for information purposes only.

Microchip Technology Drawing C04-1202-AUA Rev C Sheet 2 of 2

# DSC150X/DSC152X

## 4-Lead 2.5 mm × 2.0 mm Very Thin Land Grid Array (VLGA) Package Outline and Recommended Land Pattern [AUA]

**Note:** For the most current package drawings, please see the Microchip Packaging Specification located at <http://www.microchip.com/packaging>

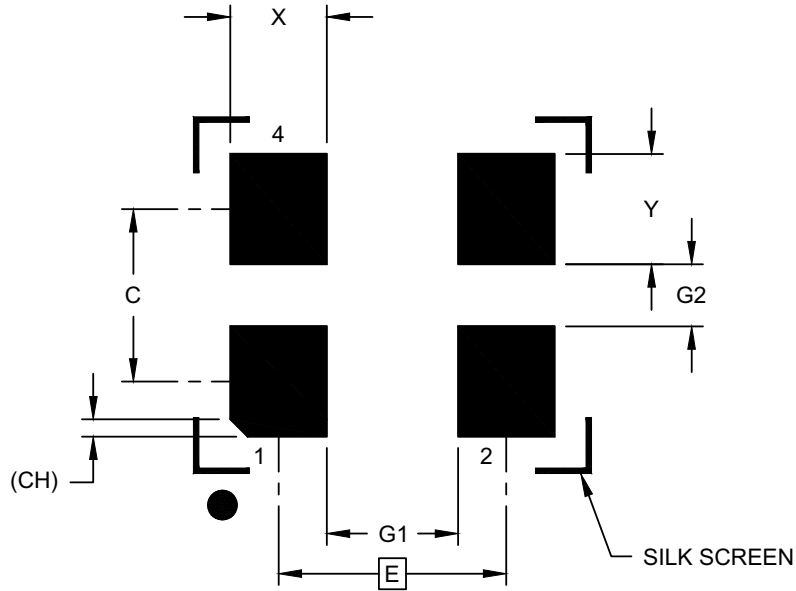

RECOMMENDED LAND PATTERN

Dimension Limits	Units	MILLIMETERS		
		MIN	NOM	MAX
Contact Pitch	E	1.65 BSC		
Contact Spacing	C		1.25	
Contact Width (X4)	X			0.70
Contact Pad Length (X4)	Y			0.80
Space Between Contacts (X2)	G1	0.95		
Space Between Contacts (X2)	G2	0.45		
Contact 1 Index Chamfer	CH	0.13 X 45° REF		

**Notes:**

1. Dimensioning and tolerancing per ASME Y14.5M  
BSC: Basic Dimension. Theoretically exact value shown without tolerances.

Microchip Technology Drawing C04-3202-AUA Rev C

# DSC150X/DSC152X

## 4-Lead 3.2 mm × 2.5 mm × 0.9 mm Very Thin Dual Flatpack (VDFN) No-Lead Package Outline and Recommended Land Pattern [H4A]

**Note:** For the most current package drawings, please see the Microchip Packaging Specification located at <http://www.microchip.com/packaging>

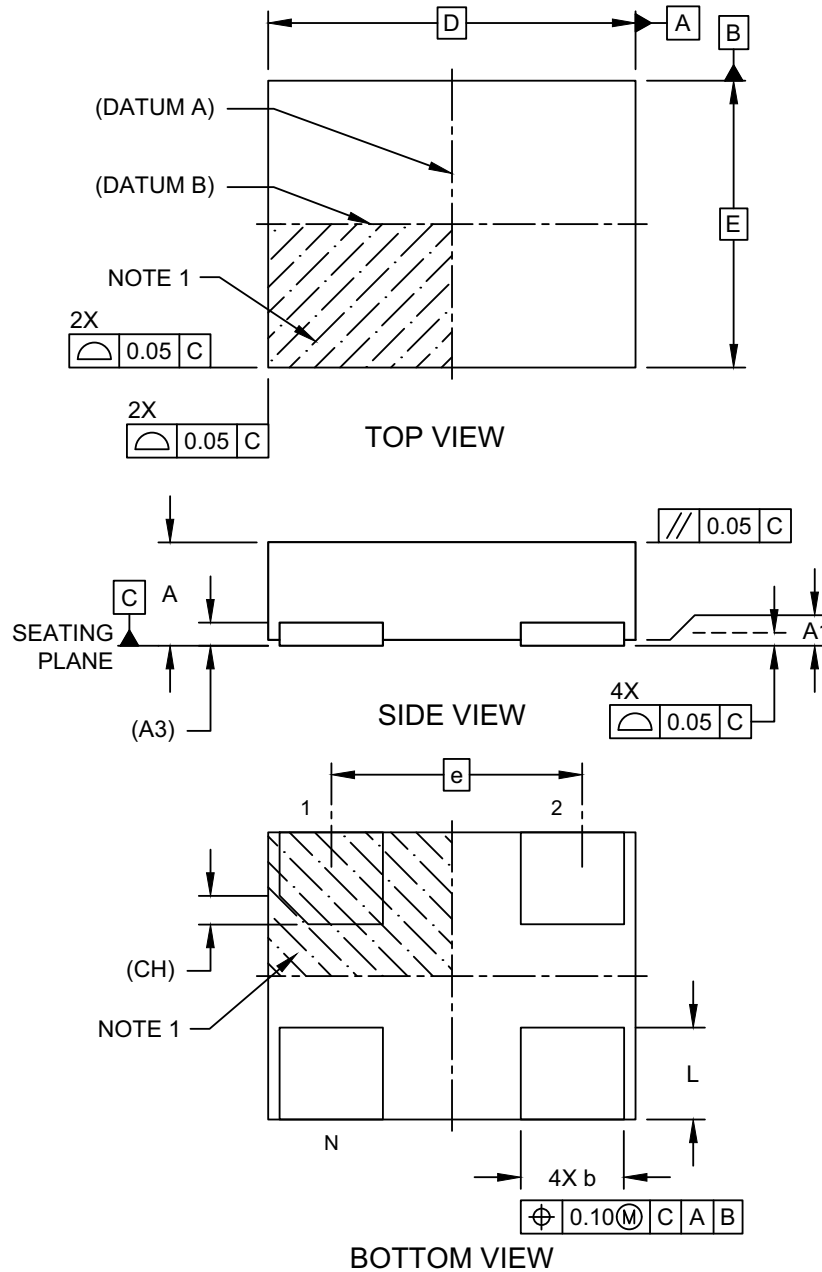

Microchip Technology Drawing C04-1006-H4A Rev C Sheet 1 of 2

# DSC150X/DSC152X

## 4-Lead 3.2 mm × 2.5 mm × 0.9 mm Very Thin Dual Flatpack (VDFN) No-Lead Package Outline and Recommended Land Pattern [H4A]

**Note:** For the most current package drawings, please see the Microchip Packaging Specification located at <http://www.microchip.com/packaging>

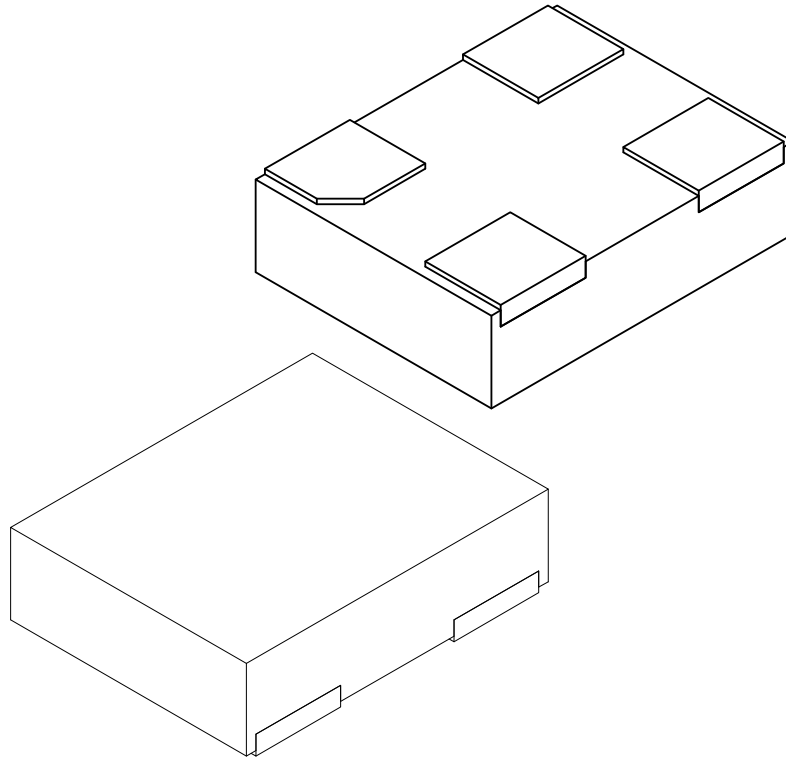

Dimension Limits	Units	MILLIMETERS		
		MIN	NOM	MAX
Number of Terminals	N	4		
Pitch	e	2.10 BSC		
Overall Height	A	0.80	0.85	0.90
Standoff	A1	0.00	0.02	0.05
Overall Length	D	3.20 BSC		
Overall Width	E	2.50 BSC		
Terminal Width	b	0.85	0.90	0.95
Terminal Length	L	0.70	0.80	0.90
Terminal 1 Index Chamfer	CH	0.25 REF		

**Notes:**

1. Pin 1 visual index feature may vary, but must be located within the hatched area.
2. Package is saw singulated
3. Dimensioning and tolerancing per ASME Y14.5M  
BSC: Basic Dimension. Theoretically exact value shown without tolerances.  
REF: Reference Dimension, usually without tolerance, for information purposes only.

Microchip Technology Drawing C04-1006-H4A Rev C Sheet 2 of 2

# DSC150X/DSC152X

## 4-Lead 3.2 mm × 2.5 mm × 0.9 mm Very Thin Dual Flatpack (VDFN) No-Lead Package Outline and Recommended Land Pattern [H4A]

**Note:** For the most current package drawings, please see the Microchip Packaging Specification located at <http://www.microchip.com/packaging>

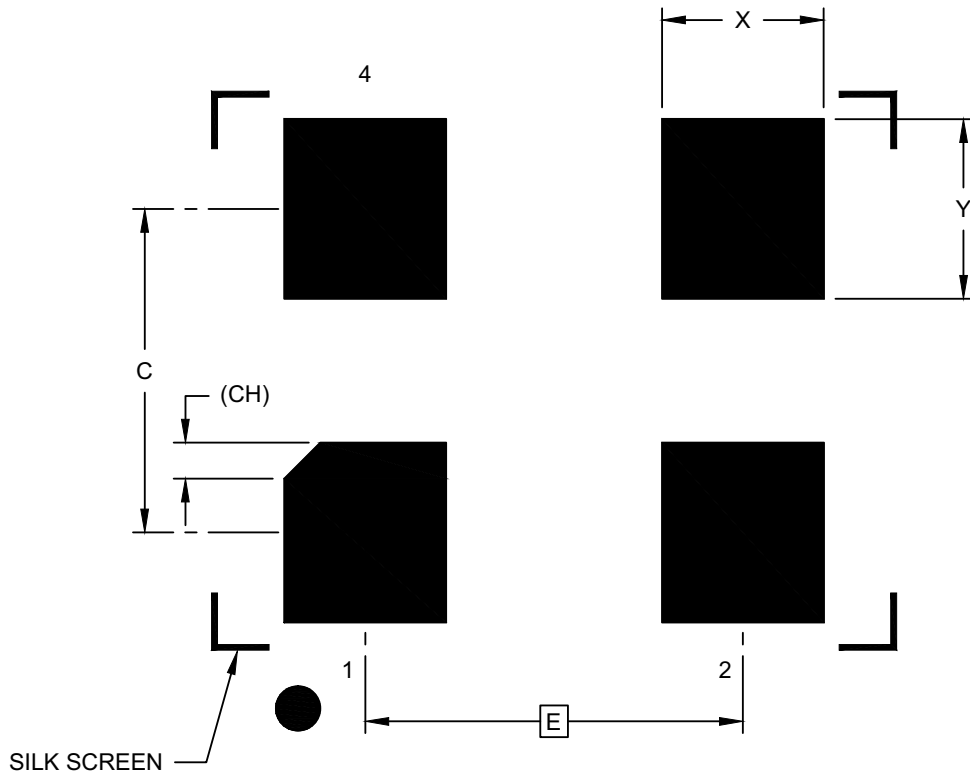

### RECOMMENDED LAND PATTERN

Dimension Limits	Units	MILLIMETERS		
		MIN	NOM	MAX
Contact Pitch	E	2.10 BSC		
Contact Pad Spacing	C		1.80	
Contact Pad Width (X4)	X			0.90
Contact Pad Length (X4)	Y			1.00
Contact 1 Index Chamfer	CH	0.20 REF		

#### Notes:

1. Dimensioning and tolerancing per ASME Y14.5M

BSC: Basic Dimension. Theoretically exact value shown without tolerances.

REF: Reference Dimension, usually without tolerance, for information purposes only.

Microchip Technology Drawing C04-3006-H4A Rev C

# DSC150X/DSC152X

## 4-Lead 5.0 mm × 3.2 mm × 0.9 mm Very Thin Dual Flatpack (VDFN) No-Lead Package Outline and Recommended Land Pattern [H6A]

**Note:** For the most current package drawings, please see the Microchip Packaging Specification located at <http://www.microchip.com/packaging>

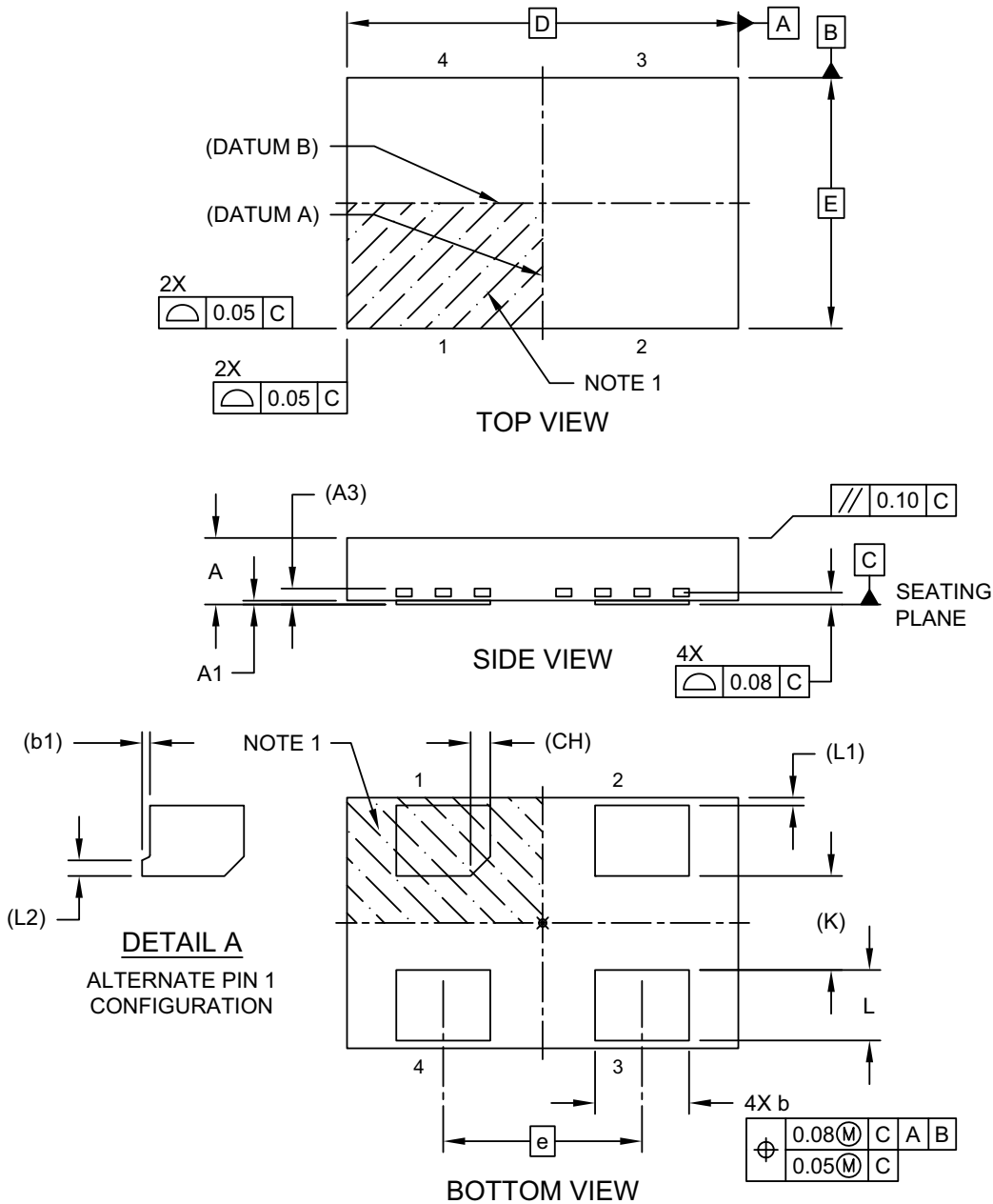

Microchip Technology Drawing C04-1008-H6A Rev C Sheet 1 of 2

# DSC150X/DSC152X

## 4-Lead 5.0 mm × 3.2 mm × 0.9 mm Very Thin Dual Flatpack (VDFN) No-Lead Package Outline and Recommended Land Pattern [H6A]

**Note:** For the most current package drawings, please see the Microchip Packaging Specification located at <http://www.microchip.com/packaging>

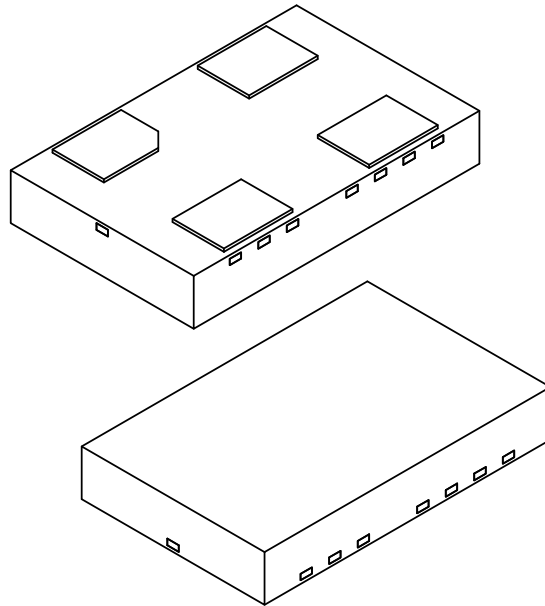

Dimension Limits	Units	MILLIMETERS		
		MIN	NOM	MAX
Number of Terminals	N	4		
Pitch	e	2.54 BSC		
Overall Height	A	0.80	0.85	0.90
Standoff	A1	0.00	0.02	0.05
Terminal Thickness	A3	0.20 REF		
Overall Length	D	5.00 BSC		
Overall Width	E	3.20 BSC		
Terminal Width	b	1.15	1.20	1.25
Terminal 1 Tab	b1	0.10 REF		
Terminal Length	L	0.80	0.90	1.00
Terminal Pull Back	L1	0.10 REF		
Terminal 1 Tab	L2	0.20 REF		
Terminal 1 Chamfer	CH	0.25 REF		
Terminal Spacing	K	1.20 REF		

**Notes:**

1. Pin 1 visual index feature may vary, but must be located within the hatched area.
2. Package is saw singulated
3. Dimensioning and tolerancing per ASME Y14.5M  
BSC: Basic Dimension. Theoretically exact value shown without tolerances.  
REF: Reference Dimension, usually without tolerance, for information purposes only.

Microchip Technology Drawing C04-1008-H6A Rev C Sheet 2 of 2

# DSC150X/DSC152X

## 4-Lead 5.0 mm × 3.2 mm × 0.9 mm Very Thin Dual Flatpack (VDFN) No-Lead Package Outline and Recommended Land Pattern [H6A]

**Note:** For the most current package drawings, please see the Microchip Packaging Specification located at <http://www.microchip.com/packaging>

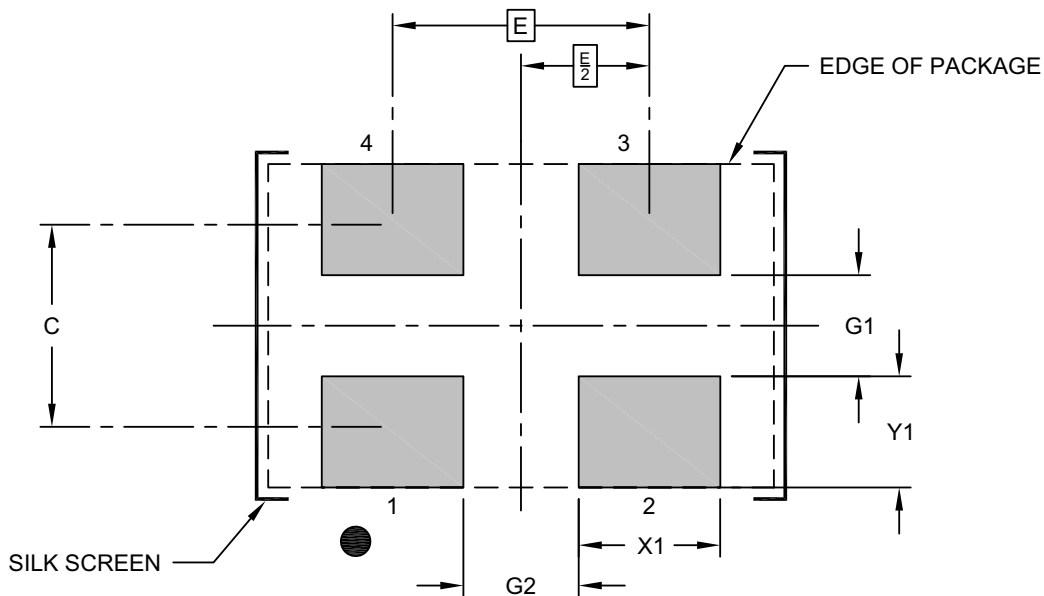

RECOMMENDED LAND PATTERN

Dimension Limits	Units	MILLIMETERS		
		MIN	NOM	MAX
Contact Pitch	E		2.54	
Contact Pad Spacing	C		2.00	
Contact Pad Width (X4)	X1			1.40
Contact Pad Length (X4)	Y1			
Contact Pad to Center Pad (X2)	G1	1.00		1.10
Contact Pad to Contact Pad (X2)	G2	1.14		
Terminal 1 Contact Pad Chamfer	CH		0.30	

**Notes:**

1. Dimensioning and tolerancing per ASME Y14.5M

BSC: Basic Dimension. Theoretically exact value shown without tolerances.

Microchip Technology Drawing C04-3008 Rev C

# DSC150X/DSC152X

## 4-Lead 7.0 mm × 5.0 mm × 0.9 mm Very Thin Dual Flatpack (VDFN) No-Lead Package with 2.2 mm × 3.5 mm Exposed Pad Package Outline and Recommended Land Pattern [JZA]

**Note:** For the most current package drawings, please see the Microchip Packaging Specification located at <http://www.microchip.com/packaging>

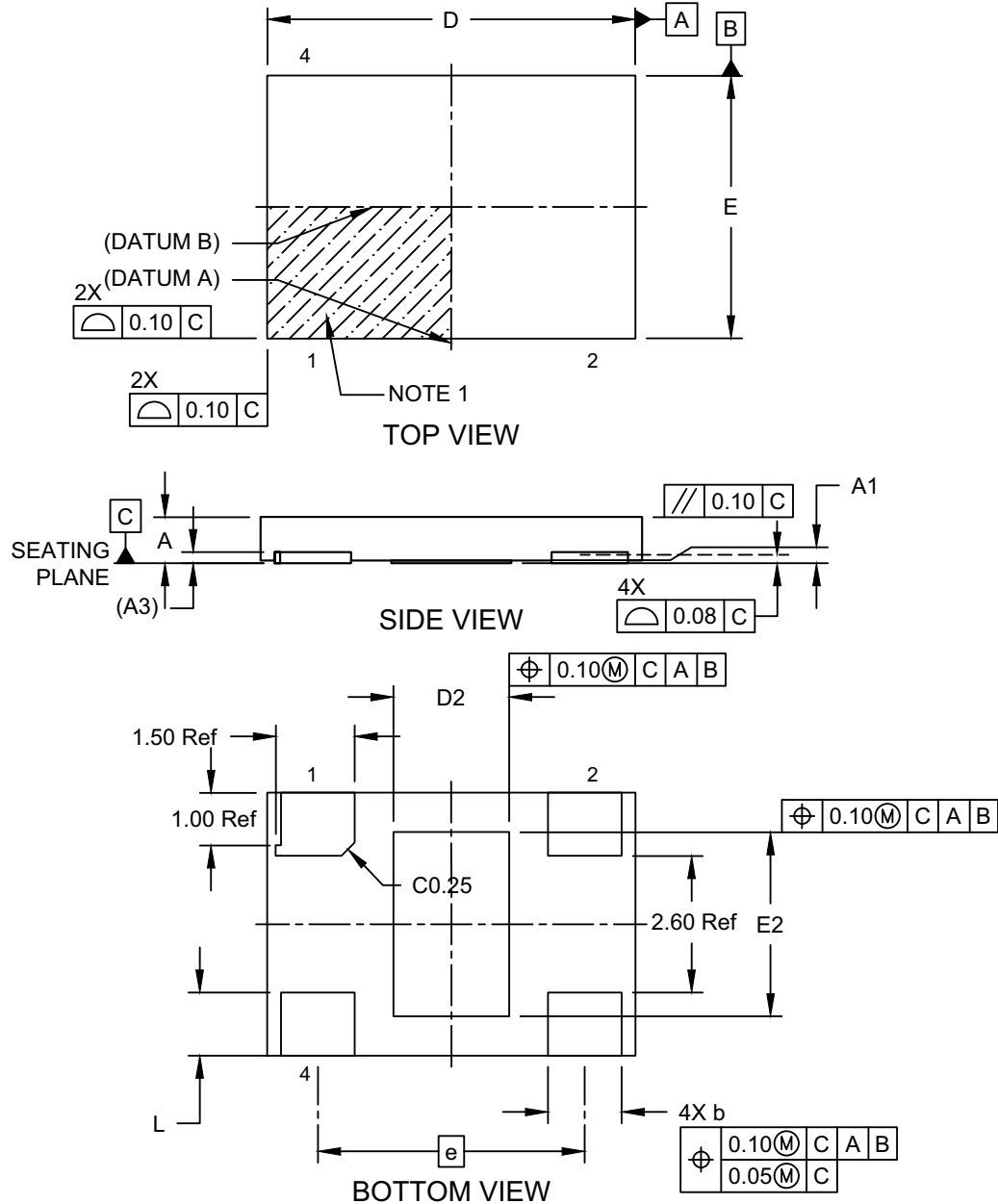

Microchip Technology Drawing C04-1025-JZA Rev B Sheet 1 of 2

# DSC150X/DSC152X

## 4-Lead 7.0 mm × 5.0 mm × 0.9 mm Very Thin Dual Flatpack (VDFN) No-Lead Package with 2.2 mm × 3.5 mm Exposed Pad Package Outline and Recommended Land Pattern [JZA]

**Note:** For the most current package drawings, please see the Microchip Packaging Specification located at <http://www.microchip.com/packaging>

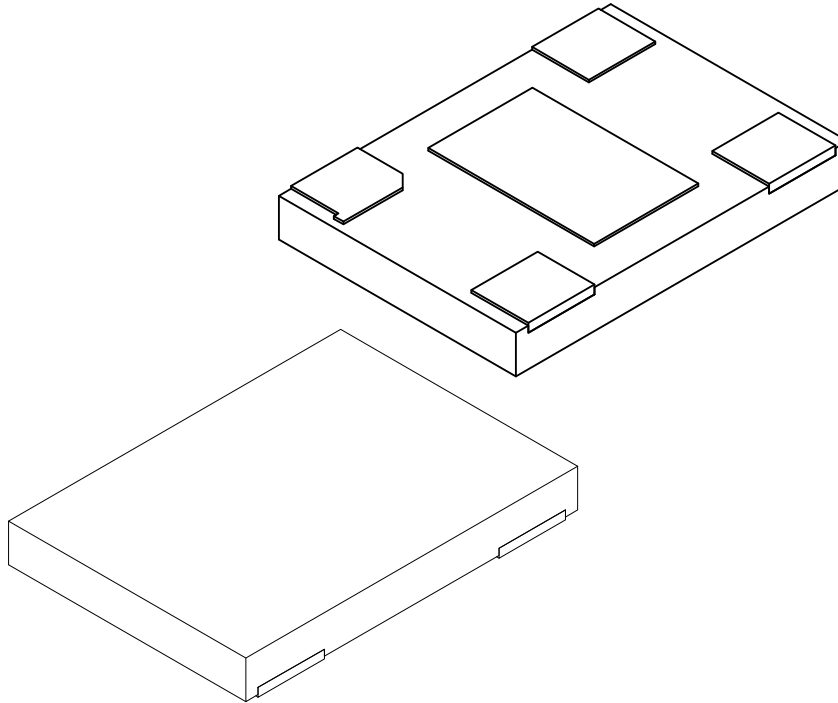

Dimension Limits	Units	MILLIMETERS		
		MIN	NOM	MAX
Number of Terminals	N	004		
Pitch	e	5.08 Ref		
Overall Height	A	0.80	0.85	0.90
Standoff	A1	0.00	-	0.05
Terminal Thickness	A3	0.203 Ref		
Overall Length	D	6.90	7.00	7.10
Exposed Pad Length	D2	2.10	2.20	2.30
Overall Width	E	4.90	5.00	5.10
Exposed Pad Width	E2	3.40	3.50	3.60
Terminal Width	b	1.35	1.40	1.45
Terminal Length	L	1.10	1.20	1.30

**Notes:**

1. Pin 1 visual index feature may vary, but must be located within the pin 1 area.
2. Package is saw singulated
3. Dimensioning and tolerancing per ASME Y14.5M  
BSC: Basic Dimension. Theoretically exact value shown without tolerances.  
REF: Reference Dimension, usually without tolerance, for information purposes only.

Microchip Technology Drawing C04-1025-JZA Rev B Sheet 2 of 2

# DSC150X/DSC152X

## 4-Lead 7.0 mm × 5.0 mm × 0.9 mm Very Thin Dual Flatpack (VDFN) No-Lead Package with 2.2 mm × 3.5 mm Exposed Pad Package Outline and Recommended Land Pattern [JZA]

**Note:** For the most current package drawings, please see the Microchip Packaging Specification located at <http://www.microchip.com/packaging>

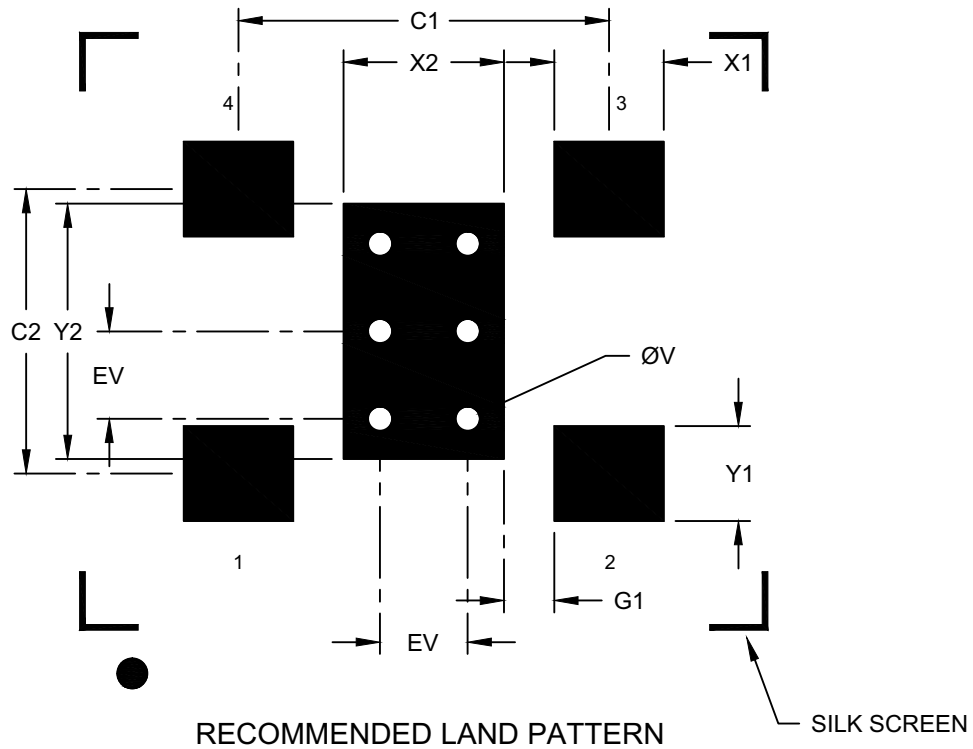

Dimension Limits	Units	MILLIMETERS		
		MIN	NOM	MAX
Optional Center Pad Width	X2			2.30
Optional Center Pad Length	Y2			3.60
Contact Pad Spacing	C1		5.08	
Contact Pad Spacing	C2		3.90	
Contact Pad Width (Xnn)	X1			1.50
Contact Pad Length (Xnn)	Y1			1.30
Contact Pad to Center Pad (Xnn)	G1	0.69		
Thermal Via Diameter	V		0.33	
Thermal Via Pitch	EV		1.20	

**Notes:**

- Dimensioning and tolerancing per ASME Y14.5M  
BSC: Basic Dimension. Theoretically exact value shown without tolerances.
- For best soldering results, thermal vias, if used, should be filled or tented to avoid solder loss during reflow process

Microchip Technology Drawing C04-3025-JZA Rev B

# DSC150X/DSC152X

---

---

NOTES:

## APPENDIX A: REVISION HISTORY

### Revision D (March 2026)

- Added a note about bulk quantities to the [Product Identification System](#) section.

### Revision C (May 2025)

- Made correction to the Conditions cell for the Supply Current row in the Electrical Characteristics table.
- Removed "A, J and M Package options only" from Frequency Stability row on the Product Identification System page.
- Added "For AEC-Q Qualified, refer to DSA150x/DSC152x Product Family" note to Features section on first page and to footnotes on PIS page.

### Revision B (December 2024)

- Added information for two additional VDFN package options (3.2 mm × 2.5 mm and 5.0 mm × 3.2 mm) throughout the data sheet.

### Revision A (June 2021)

- Initial release of DSC150x/DSC152x as Microchip data sheet DS20006516A.

# DSC150X/DSC152X

---

NOTES:

# DSC150X/DSC152X

## PRODUCT IDENTIFICATION SYSTEM

To order or obtain information, e.g., on pricing or delivery, contact your local Microchip representative or sales office.

<u>PART NO.</u>	X	X	X	X	X	X	X	-XXXXXXXX	X
Device	Control Pin	Output Drive Strength	Package	Temperature	Stability	Revision	Output Frequency	Media Type	
<b>Device:</b>	DSC15:	Low-Power Low-Jitter CMOS MEMS Oscillator							
<b>Control Pin:</b>	0	=	Standby Function (STB)						
	2	=	Enable/Disable Function (OE)						
<b>Output Drive Strength:</b>	1	=	LVCMOS Medium Drive (2.5V.3.3V)						
	2	=	LVCMOS Standard Drive (2.5V.3.3V)						
	3	=	LVCMOS Low Drive (2.5V.3.3V)						
	4	=	LVCMOS Low Drive (1.8V)						
	5	=	LVCMOS Standard Drive (1.8V)						
<b>Package:</b>	A	=	7.0 mm × 5.0 mm 4-Lead VDFN						
	B	=	5.0 mm × 3.2 mm 4-Lead VDFN						
	C	=	3.2 mm × 2.5 mm 4-Lead VDFN						
	J	=	2.5 mm × 2.0 mm 4-Lead VLGA						
	M	=	2.0 mm × 1.6 mm 4-Lead VLGA						
<b>Temperature:</b>	E	=	-20°C to +70°C (Extended Commercial)						
	I	=	-40°C to +85°C (Industrial)						
	L	=	-40°C to +105°C (Extended Industrial)						
	A	=	-40°C to +125°C (Automotive)						
<b>Frequency Stability:</b>	1	=	±50 ppm						
	2	=	±25 ppm						
	3	=	±20 ppm						
<b>Revision:</b>	A	=	Revision A						
<b>Output Frequency:</b>	xMxxxxx=	≤	9.999999 MHz						
	xxMxxxxx=	10.00000 MHz to	99.99999 MHz						
	xxxMxxxxx=	≥	100.0000 MHz						
<b>Media Type:</b>	<blank>	=	Bulk (100/Bag) for 2.0 mm × 1.6 mm Package						
<b>(Note 3)</b>	T	=	Bulk in Tube for Other Packages						
		=	1,000/Reel						
	B	=	3,000/Reel						

**Examples:**

a) DSC1521ML3A-50M00000: Pin1 OE, CMOS Medium Drive, 4-Lead 2.0 mm × 1.6 mm, -40°C to 105°C Temperature Range, ±20 ppm, 50 MHz, Bulk.

b) DSC1502J11A-100M0000T: Pin1 STB, CMOS Standard Drive, 4-Lead 2.5 mm × 2.0 mm, -40°C to 85°C Temperature Range, ±50 ppm, 100 MHz, 1,000 Reel.

**Note 1:** Tape and Reel identifier only appears in the catalog part number description. This identifier is used for ordering purposes and is not printed on the device package. Check with your Microchip Sales Office for package availability with the Tape and Reel option.

**2:** For AEC-Q Qualified, refer to DSA150x/DSA152x Product Family.

**3:** On orders for bulk CPNs, product may be supplied in either cut tape (without a reel) or tube packaging, depending on availability. For Tape & Reel orders that are <1000 pieces, product may be supplied on cut tape (without a reel) depending on availability.

Please visit the [Microchip ClockWorks Configurator®](http://clockworks.microchip.com/timing) website to configure the part number for customized frequency select settings.  
<http://clockworks.microchip.com/timing>

# DSC150X/DSC152X

---

NOTES:

---

---

## Microchip Information

### Trademarks

The “Microchip” name and logo, the “M” logo, and other names, logos, and brands are registered and unregistered trademarks of Microchip Technology Incorporated or its affiliates and/or subsidiaries in the United States and/or other countries (“Microchip Trademarks”). Information regarding Microchip Trademarks can be found at <https://www.microchip.com/en-us/about/legal-information/microchip-trademarks>.

ISBN: 979-8-3371-3034-7

### Legal Notice

This publication and the information herein may be used only with Microchip products, including to design, test, and integrate Microchip products with your application. Use of this information in any other manner violates these terms. Information regarding device applications is provided only for your convenience and may be superseded by updates. It is your responsibility to ensure that your application meets with your specifications. Contact your local Microchip sales office for additional support or, obtain additional support at [www.microchip.com/en-us/support/design-help/client-support-services](http://www.microchip.com/en-us/support/design-help/client-support-services).

THIS INFORMATION IS PROVIDED BY MICROCHIP "AS IS". MICROCHIP MAKES NO REPRESENTATIONS OR WARRANTIES OF ANY KIND WHETHER EXPRESS OR IMPLIED, WRITTEN OR ORAL, STATUTORY OR OTHERWISE, RELATED TO THE INFORMATION INCLUDING BUT NOT LIMITED TO ANY IMPLIED WARRANTIES OF NON-INFRINGEMENT, MERCHANTABILITY, AND FITNESS FOR A PARTICULAR PURPOSE, OR WARRANTIES RELATED TO ITS CONDITION, QUALITY, OR PERFORMANCE.

IN NO EVENT WILL MICROCHIP BE LIABLE FOR ANY INDIRECT, SPECIAL, PUNITIVE, INCIDENTAL, OR CONSEQUENTIAL LOSS, DAMAGE, COST, OR EXPENSE OF ANY KIND WHATSOEVER RELATED TO THE INFORMATION OR ITS USE, HOWEVER CAUSED, EVEN IF MICROCHIP HAS BEEN ADVISED OF THE POSSIBILITY OR THE DAMAGES ARE FORESEEABLE. TO THE FULLEST EXTENT ALLOWED BY LAW, MICROCHIP'S TOTAL LIABILITY ON ALL CLAIMS IN ANY WAY RELATED TO THE INFORMATION OR ITS USE WILL NOT EXCEED THE AMOUNT OF FEES, IF ANY, THAT YOU HAVE PAID DIRECTLY TO MICROCHIP FOR THE INFORMATION.

Use of Microchip devices in life support and/or safety applications is entirely at the buyer's risk, and the buyer agrees to defend, indemnify and hold harmless Microchip from any and all damages, claims, suits, or expenses resulting from such use. No licenses are conveyed, implicitly or otherwise, under any Microchip intellectual property rights unless otherwise stated.

### Microchip Devices Code Protection Feature

Note the following details of the code protection feature on Microchip products:

- Microchip products meet the specifications contained in their particular Microchip Data Sheet.
- Microchip believes that its family of products is secure when used in the intended manner, within operating specifications, and under normal conditions.
- Microchip values and aggressively protects its intellectual property rights. Attempts to breach the code protection features of Microchip product is strictly prohibited and may violate the Digital Millennium Copyright Act.
- Neither Microchip nor any other semiconductor manufacturer can guarantee the security of its code. Code protection does not mean that we are guaranteeing the product is “unbreakable”. Code protection is constantly evolving. Microchip is committed to continuously improving the code protection features of our products.