

Feb.1.2018 Copyright 2018 HIROSE ELECTRIC CO., LTD. All Rights Reserved.

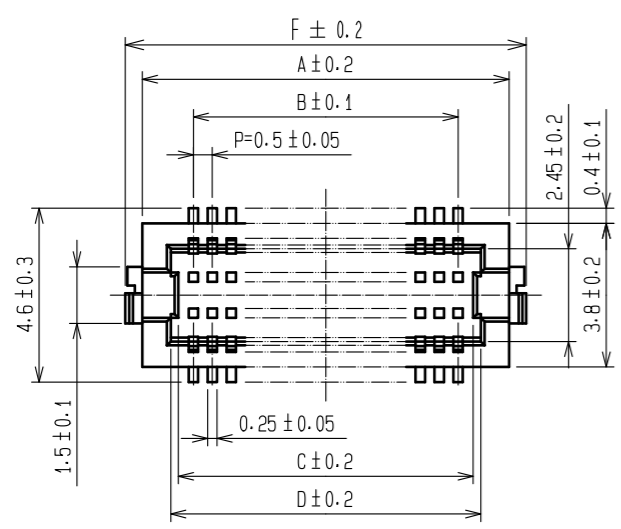

G-G (10:1)

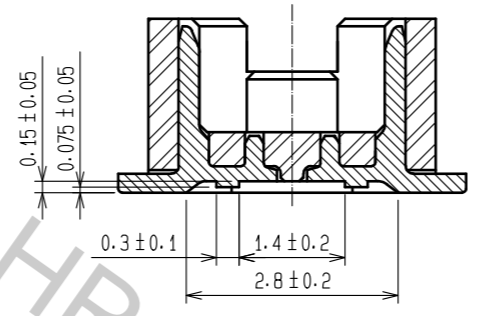

CODE NO.	CONTACT	A	B	C	D	E	F
CL537-0756-4-86	10	4.7	2.0	2.8	3.2	2.8	5.6
CL537-0919-7-86	14	5.7	3.0	3.8	4.2	3.8	6.6
CL537-0758-0-86	20	7.2	4.5	5.3	5.7	5.3	8.1
CL537-0760-1-86	30	9.7	7.0	7.8	8.2	7.8	10.6
CL537-0767-0-86	32	10.2	7.5	8.3	8.7	8.3	11.1
CL537-0761-4-86	36	11.2	8.5	9.3	9.7	9.3	12.1
CL537-0762-7-86	40	12.2	9.5	10.3	10.7	10.3	13.1
CL537-0764-2-86	50	14.7	12.0	12.8	13.2	12.8	15.6
CL537-0766-8-86	60	17.2	14.5	15.3	15.7	15.3	18.1
CL537-0768-3-86	80	22.2	19.5	20.3	20.7	20.3	23.1

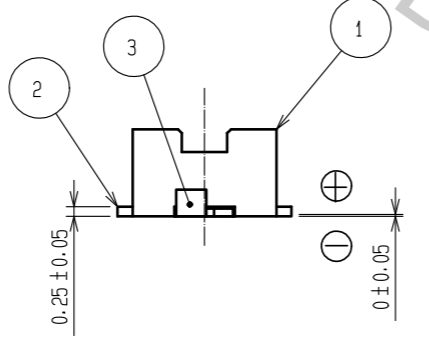
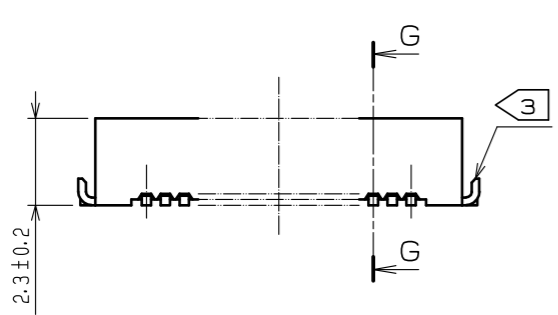

RECOMMENDED METAL MASK PATTERN (10:1)

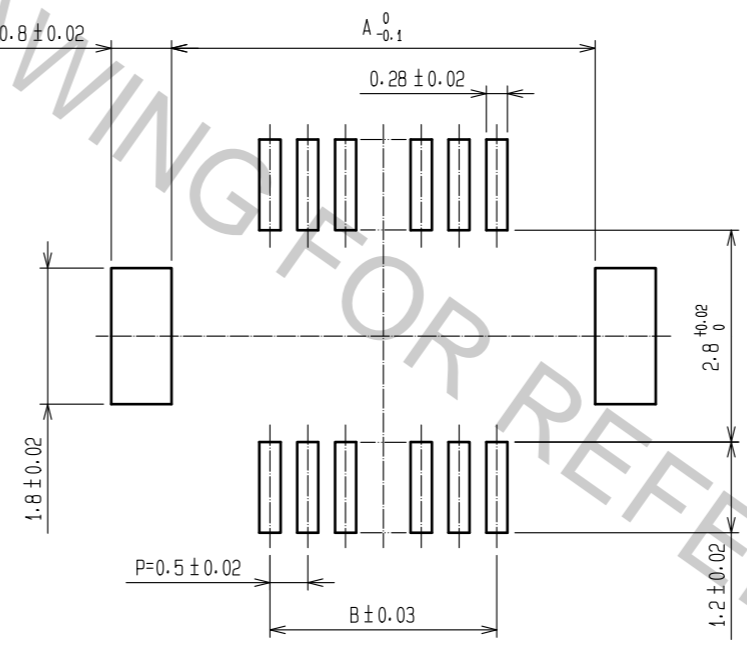

RECOMMENDED PATTERN (10:1)

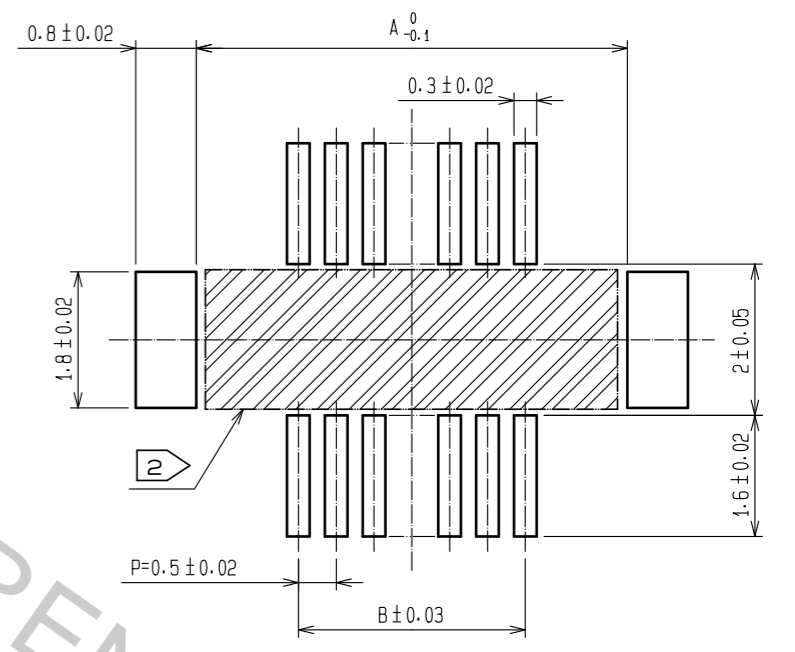

RECOMMENDED THICKNESS OF METAL MASK: 120µm

RECOMMENDED THICKNESS OF SOLDER PASTE: 120µm

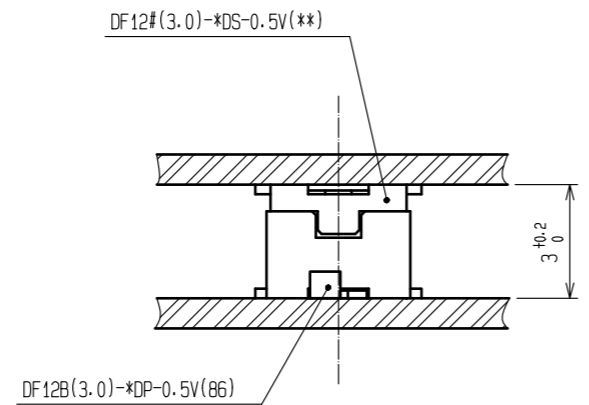
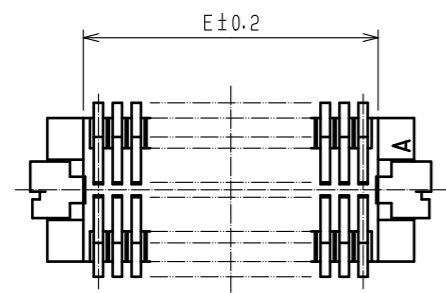

- NOTES 1 LEAD CO-PLANARITY INCLUDING REINFORCED METAL FITTINGS SHALL BE 0.08 mm MAX.  
 2 IF THERE IS PATTERN ON PART, THERE IS A POSSIBILITY THAT IT WILL MAKE CONTACT WITH THE LEADS.  
 3 REINFORCED METAL FITTINGS AS FOLLOWS.

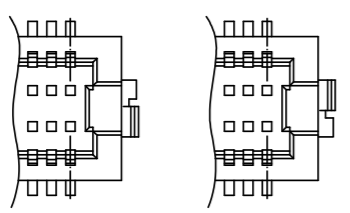

NO.	MATERIAL	FINISH . REMARKS	NO.	MATERIAL	FINISH . REMARKS
2	PHOSPHOR BRONZE	CONTACT AREA:GOLD PLATED 0.2µm min LEAD AREA:GOLD PLATED 0.015µm min OTHERS(UNDER PLATING):NICKEL 2µm min	7	PS	CLEAR(REINFORCEMENT COLLAR)
1	POLYAMIDE	BEIGE, UL94V-0	6	PS	BLACK(PLASTIC REEL)
			5	POLYESTER	CLEAR(COVER TAPE)
			4	PS	CLEAR(EMBOSSED CARRIER TAPE)
			3	BRASS	TIN PLATED 2µm min UNDER PLATING:NICKEL 1µm min

  

UNITS	SCALE	COUNT	DESCRIPTION OF REVISIONS	DESIGNED	CHECKED	DATE
mm	5 : 1	1	DIS-H-00001707	SH. HOSODA	TS. MIYAZAKI	16.06.10

  

APPROVED	DATE	DRAWING NO.
KH. IKEDA	13.08.19	EDC3-160780-77
YH. MICHIDA	13.08.08	PART NO.
YN. SAKAMOTO	13.08.08	DF12B(3.0)-*DP-0.5V(86)
KR. AJITO	13.08.08	CODE NO.
		CL537

Feb.1.2018 Copyright 2018 HIROSE ELECTRIC CO., LTD. All Rights Reserved.

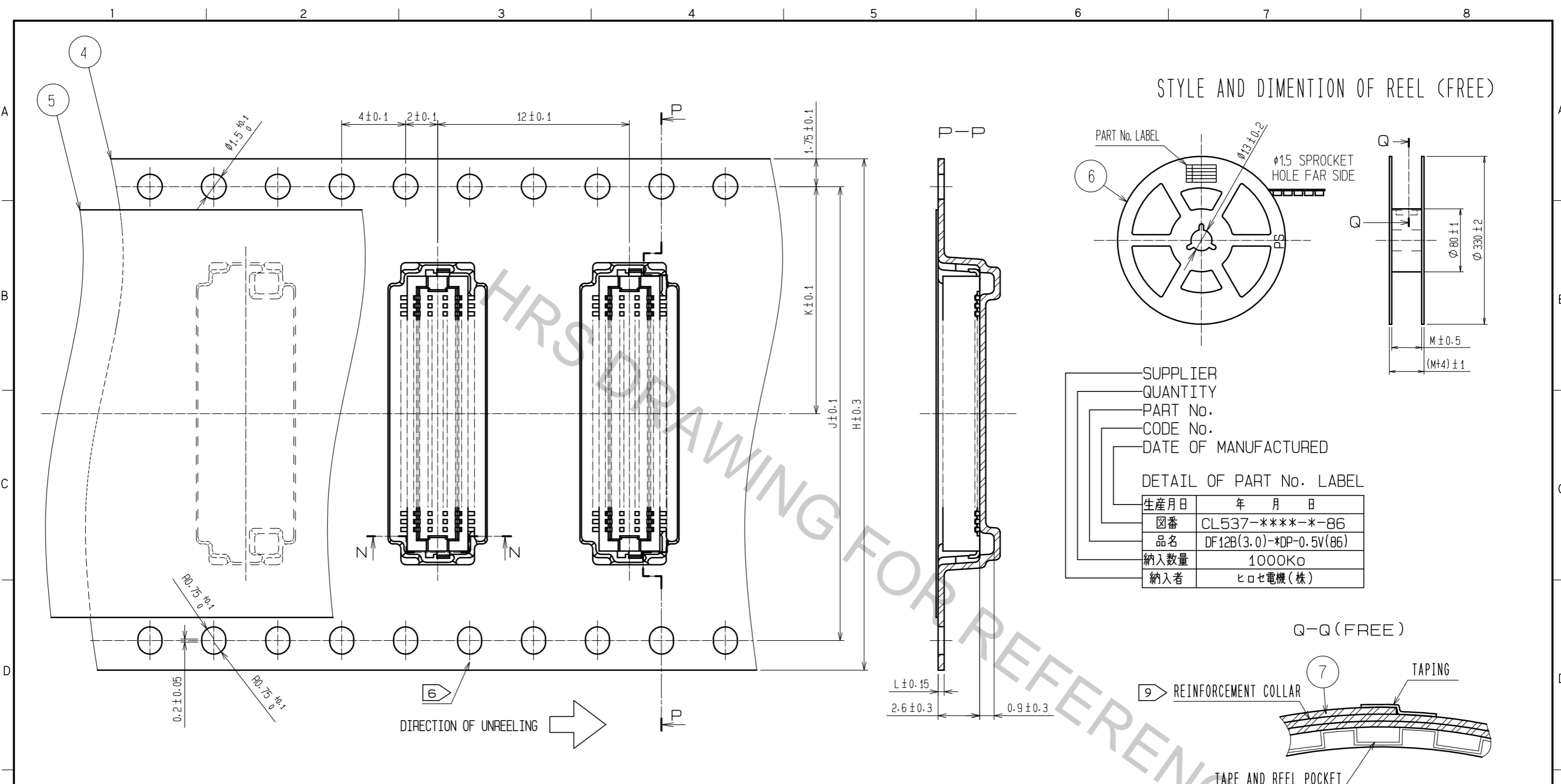

CODE No.	CONTACT	H	J	K	L	M
CL537-0756-4-86	10	16	-	7.5	0.30	17.5
CL537-0919-7-86	14	16	-	7.5	0.30	17.5
CL537-0758-0-86	20	16	-	7.5	0.38	17.5
CL537-0760-1-86	30	24	-	11.5	0.38	25.5
CL537-0767-0-86	32	24	-	11.5	0.30	25.5
CL537-0761-4-86	36	24	-	11.5	0.38	25.5
CL537-0762-7-86	40	24	-	11.5	0.38	25.5
CL537-0764-2-86	50	24	-	11.5	0.38	25.5
CL537-0766-8-86	60	32	28.4	14.2	0.38	33.5
CL537-0768-3-86	80	44	40.4	20.2	0.38	45.5

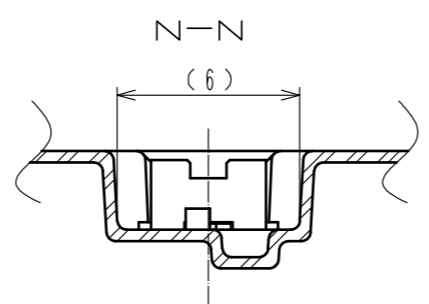

- NOTES
- 4 1 REEL 1000 CONNECTORS.
  - 5 AT THE BEGINNING OF THE REEL, 30 COMPONENTS SHALL BE EMPTY. AT THE END OF THE REEL, 20 COMPONENTS SHALL BE EMPTY.
  - 6 WHEN THE TAPE WIDTH IS 32 mm OR 44mm, SPROCKET HOLES SHALL BE SET ON BOTH SIDE OF REEL AS SHOWN ON THIS DRAWING.
  - 7 PEEL FORCE REFERS TO JIS C 0806. (IEC 60286-3)
  - 8 THE REEL IS PACKED WITH A POLYETHYLENE MATERIAL, TOGETHER WITH A DRYING AGENT.
  - 9 AFTER PACKING, ROLL 2 METERS OF THE REINFORCEMENT COLLAR TO OUTER CIRCUMFERENCE OF TAPE AND REEL POCKET, AND TAPE DOWN AT THE END THE COLLAR.

<b>HRS</b>	DRAWING NO.	EDC3-160780-77
	PART NO.	DF12B(3.0)-*DP-0.5V(86)
	CODE NO.	CL537
		2/2