

AGILA

2475YGO050P40

EAN 4031582356380

Swivel castor with wheel brake, housing made of pressed steel, bright zinc plated, blue passivated, double ball bearing swivel head, plate fitting. Wheel centre made of Polypropylene, electric conductive, Tread: TENTEprene (thermoplastic rubber), grey non-marking, plain bearing



BETTER MOBILITY. BETTER LIFE.



Picture may differ from original product

Technical Data

Wheel diameter	50 mm
Width of Tread	19 mm
Size of Plate	60 x 60 mm
Plate hole centres	48/38 x 48/38 mm
Plate hole	6,3 mm
Offset	24 mm
Overall height	69 mm
Temperature	- 20 / + 60 °C
Standard	EN 12530
Weight	0.171 kg
Hardness of tread	Shore A 87
Load capacity	50 kg
Load capacity (static)	100 kg

Structure & Mounting

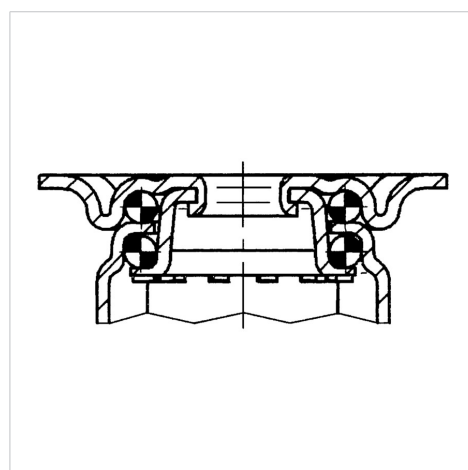

Advantages at a glance

Roll performance	● ● ● ○ ○
Movement noise	● ● ● ○ ○
Attrition	● ● ● ○ ○
Corrosion resistance	● ● ● ○ ○

AGILA

2475YGO050P40

EAN 4031582356380



BETTER MOBILITY. BETTER LIFE.

Structure & Mounting

