

Copying of this document, and giving it to others and the use or communication of the contents thereof, are forbidden without express authority. Offenders are liable to the payment of damages. All rights are reserved in the event of the grant of a patent or the registration of a utility model or design.

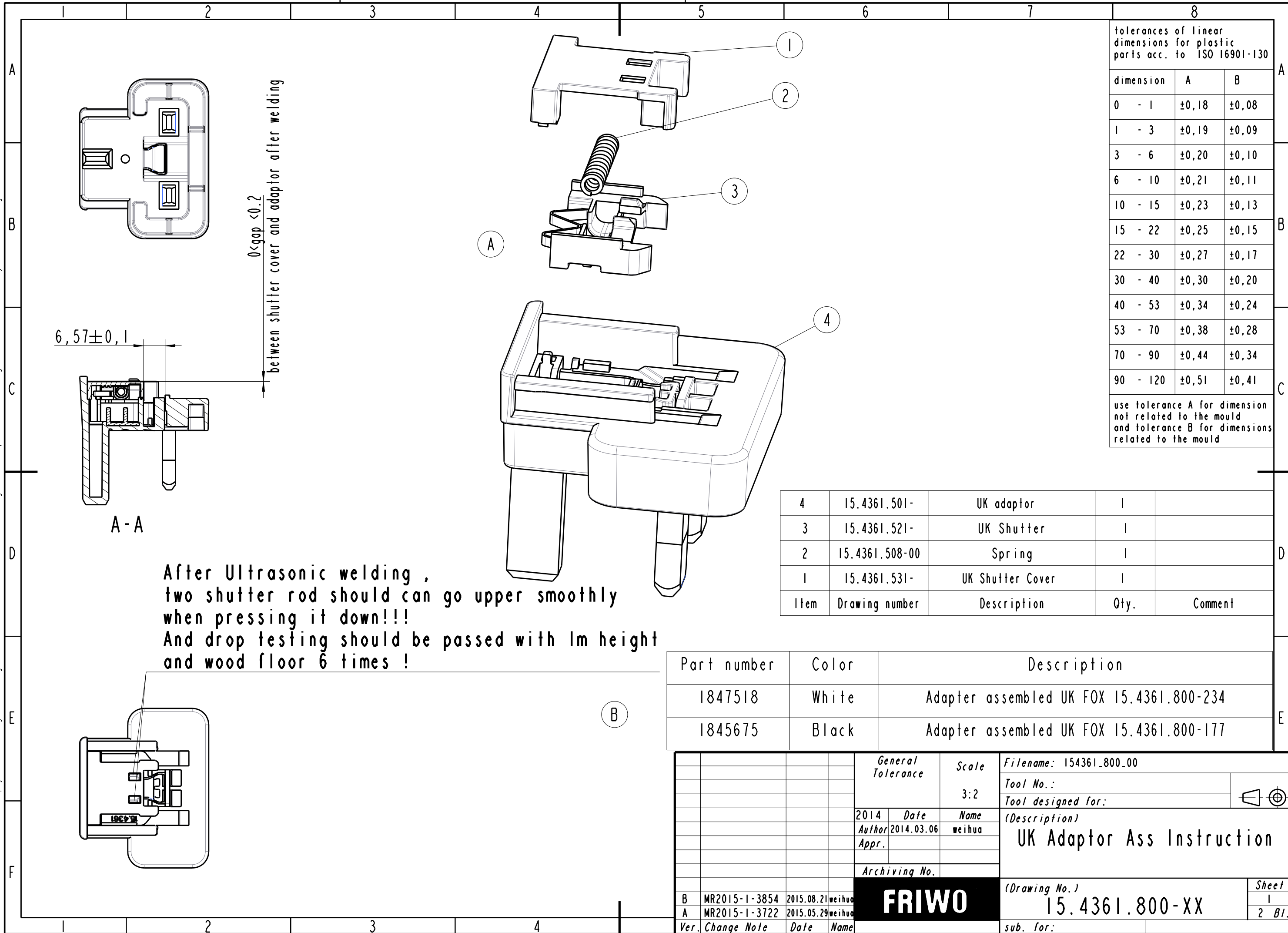

tolerances of linear dimensions for plastic parts acc. to ISO 16901-130

dimension	A	B
0 - 1	±0,18	±0,08
1 - 3	±0,19	±0,09
3 - 6	±0,20	±0,10
6 - 10	±0,21	±0,11
10 - 15	±0,23	±0,13
15 - 22	±0,25	±0,15
22 - 30	±0,27	±0,17
30 - 40	±0,30	±0,20
40 - 53	±0,34	±0,24
53 - 70	±0,38	±0,28
70 - 90	±0,44	±0,34
90 - 120	±0,51	±0,41

use tolerance A for dimension not related to the mould and tolerance B for dimensions related to the mould

Item	Drawing number	Description	Qty.	Comment
4	15.4361.501-	UK adaptor	1	
3	15.4361.521-	UK Shutter	1	
2	15.4361.508-00	Spring	1	
1	15.4361.531-	UK Shutter Cover	1	

After Ultrasonic welding ,
two shutter rod should can go upper smoothly
when pressing it down!!!
And drop testing should be passed with 1m height
and wood floor 6 times !

Part number	Color	Description
1847518	White	Adapter assembled UK FOX 15.4361.800-234
1845675	Black	Adapter assembled UK FOX 15.4361.800-177

General Tolerance		Scale	Filename: 154361.800.00	
		3:2	Tool No.:	
			Tool designed for:	
2014	Date	Name	(Description)	
Author	2014.03.06	weihua	UK Adaptor Ass Instruction	
Appr.				
		Archiving No.	(Drawing No.)	
B	MR2015-1-3854	2015.08.21	15.4361.800-XX	
A	MR2015-1-3722	2015.05.29	Sheet	
Ver. Change Note		Date	2 Bl.	
		Name	sub. for:	

FRIWO

Copying of this document, and giving it to others and the use or communication of the contents thereof, are forbidden without express authority. Offenders are liable to the payment of damages. All rights are reserved in the event of the grant of a patent or the registration of a utility model or design.

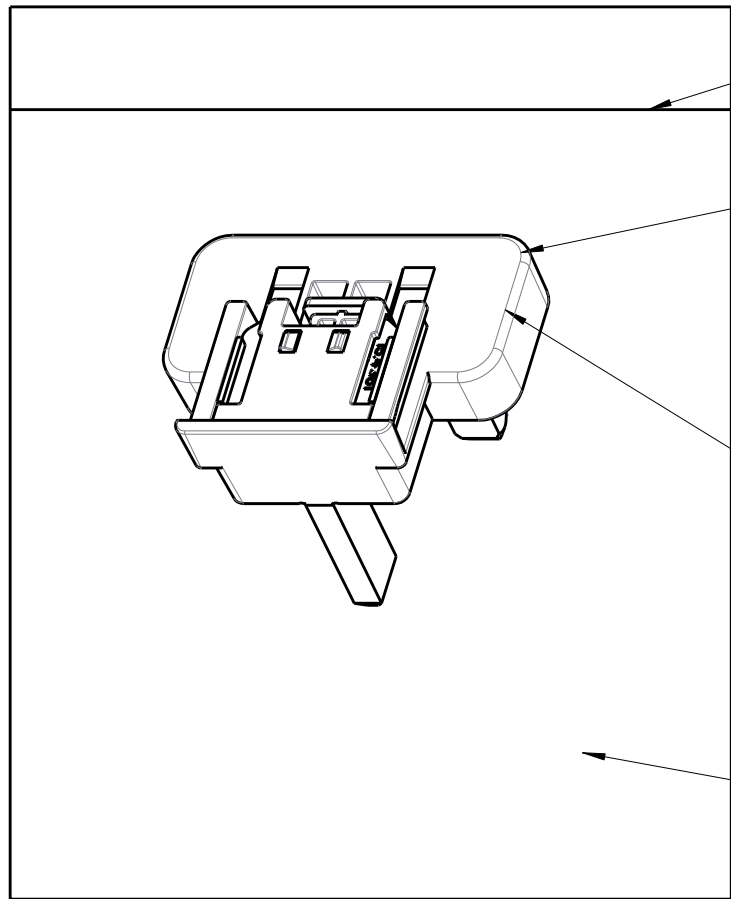

Part number	Color	Description
1847543	White	Adapter assembled UK packed FOX 15.4361.800-234
1847544	Black	Adapter assembled UK packed FOX 15.4361.800-177

		General Tolerance	Scale	Filename: 154361.800.00	
			1:1	Tool No.:	
				Tool designed for:	
		2014	Date	(Description)	
		Author	2014.03.06	UK Adaptor Ass Instruction	
		Appr.			
		Archiving No.			
		FRIWO		(Drawing No.)	
				15.4361.800-XX	
B	MR2015-1-3854	2015.08.21	weihua	Sheet	
A	MR2015-1-3722	2015.05.29	weihua	2	
Ver. Change Note		Date	Name	sub. for:	

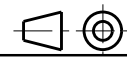

2
Bl.