













# 5/2-directional valve, Series TC15

- Operating voltage 24 V DC
- 5/2
- Qn = 1500 l/min
- Pilot valve width : 15 mm
- Pipe connection
- Compressed air connection output : G 1/4
- Electrical connection : Plug, M8, 3-pin
- Manual override : with detent
- single solenoid double solenoid
- Pilot : Internal External



Type	Spool valve, positive overlapping
Activation	Electrically
Sealing principle	Soft sealing
Working pressure min./max.	See table below
Control pressure min./max.	See table below
Ambient temperature min./max.	-10 ... 50 °C
Medium temperature min./max.	-10 ... 50 °C
Medium	Compressed air
Max. particle size	5 µm
Oil content of compressed air	0 ... 5 mg/m <sup>3</sup>
Nominal flow Qn	1500 l/min
Connector standard	DIN EN 60947-5-2
Protection class acc. to DIN EN 61140 Electrically	Class III
Protection class with connection	IP65
LED status display	Yellow
Duty cycle	100 %
Mounting on manifold strip	P-strip
Mounting screw tightening torque	2,5 Nm
Weight	See table below
Comment	An example configuration is illustrated. The delivered product may thus deviate from the illustration.

## Technical data

Part No.		MO	Compressed air connection	
			Input	Output
R422100986			G 1/4	G 1/4
R422100987			G 1/4	G 1/4
R422100988			G 1/4	G 1/4
R422100989			G 1/4	G 1/4
R422100990			G 1/4	G 1/4
R422100991			G 1/4	G 1/4

Part No.	Compressed air connection	
	Exhaust	Pilot Input
R422100986	G 1/4	-
R422100987	G 1/4	M5
R422100988	G 1/4	-
R422100989	G 1/4	M5
R422100990	G 1/4	-
R422100991	G 1/4	M5

Part No.	Operational voltage	Voltage tolerance	Power consumption	Pilot
	DC	DC	DC	
R422100986	24 V	-10% / +10%	2,2 W	Internal
R422100987	24 V	-10% / +10%	2,2 W	External
R422100988	24 V	-10% / +10%	2,2 W	Internal
R422100989	24 V	-10% / +10%	2,2 W	External
R422100990	24 V	-10% / +10%	2,2 W	Internal
R422100991	24 V	-10% / +10%	2,2 W	External

Part No.	Flow conductance	Flow conductance	Nominal resistance	Working pressure min./max.
	b	C-value		
R422100986	0,33	6,8 l/(s*bar)	280 Ω	2,5 ... 10 bar
R422100987	0,33	6,8 l/(s*bar)	280 Ω	-0,9 ... 10 bar
R422100988	0,33	6,8 l/(s*bar)	280 Ω	3 ... 10 bar
R422100989	0,33	6,8 l/(s*bar)	280 Ω	-0,9 ... 10 bar
R422100990	0,33	6,8 l/(s*bar)	280 Ω	2 ... 10 bar
R422100991	0,33	6,8 l/(s*bar)	280 Ω	-0,9 ... 10 bar

Part No.	Control pressure min./max.	Typ. switch-on time	Typ. switch-off time	Weight
R422100986	2,5 ... 10 bar	21 ms	22 ms	0,235 kg
R422100987	2,5 ... 10 bar	21 ms	22 ms	0,235 kg
R422100988	3 ... 10 bar	12 ms	35 ms	0,235 kg
R422100989	3 ... 10 bar	12 ms	35 ms	0,235 kg
R422100990	2 ... 10 bar	10 ms	10 ms	0,265 kg
R422100991	2 ... 10 bar	10 ms	10 ms	0,265 kg

Nominal flow  $Q_n$  at 6 bar and  $\Delta p = 1$  bar, MO = Manual override

## Technical information

The min. control pressure must be adhered to, since otherwise faulty switching and valve failure may result!

The pressure dew point must be at least 15 °C under ambient and medium temperature and may not exceed 3 °C .

The oil content of compressed air must remain constant during the life cycle.

Use only the approved oils from AVENTICS. Further information can be found in the "Technical information" document (available in the MediaCentre).

## Technical information

Material	
Housing	Polyamide fiber-glass reinforced
Seals	Acrylonitrile butadiene rubber Hydrogenated nitrile butadiene rubber
Front plate	Polyamide fiber-glass reinforced
Threaded bushing	Brass Die cast zinc, nickel-plated chrome-plated

# Dimensions

## Dimensions, single solenoid

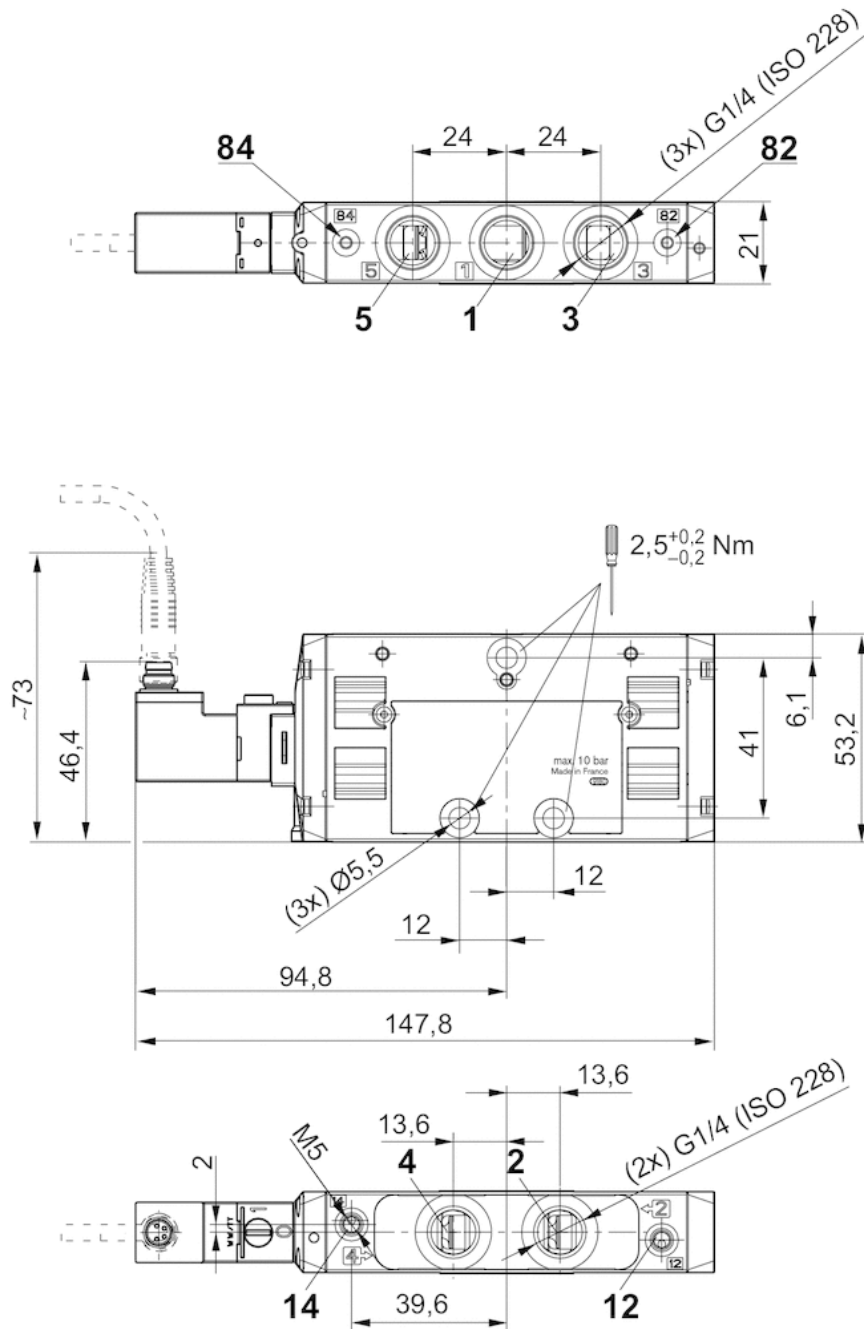

Dimensions, double solenoid

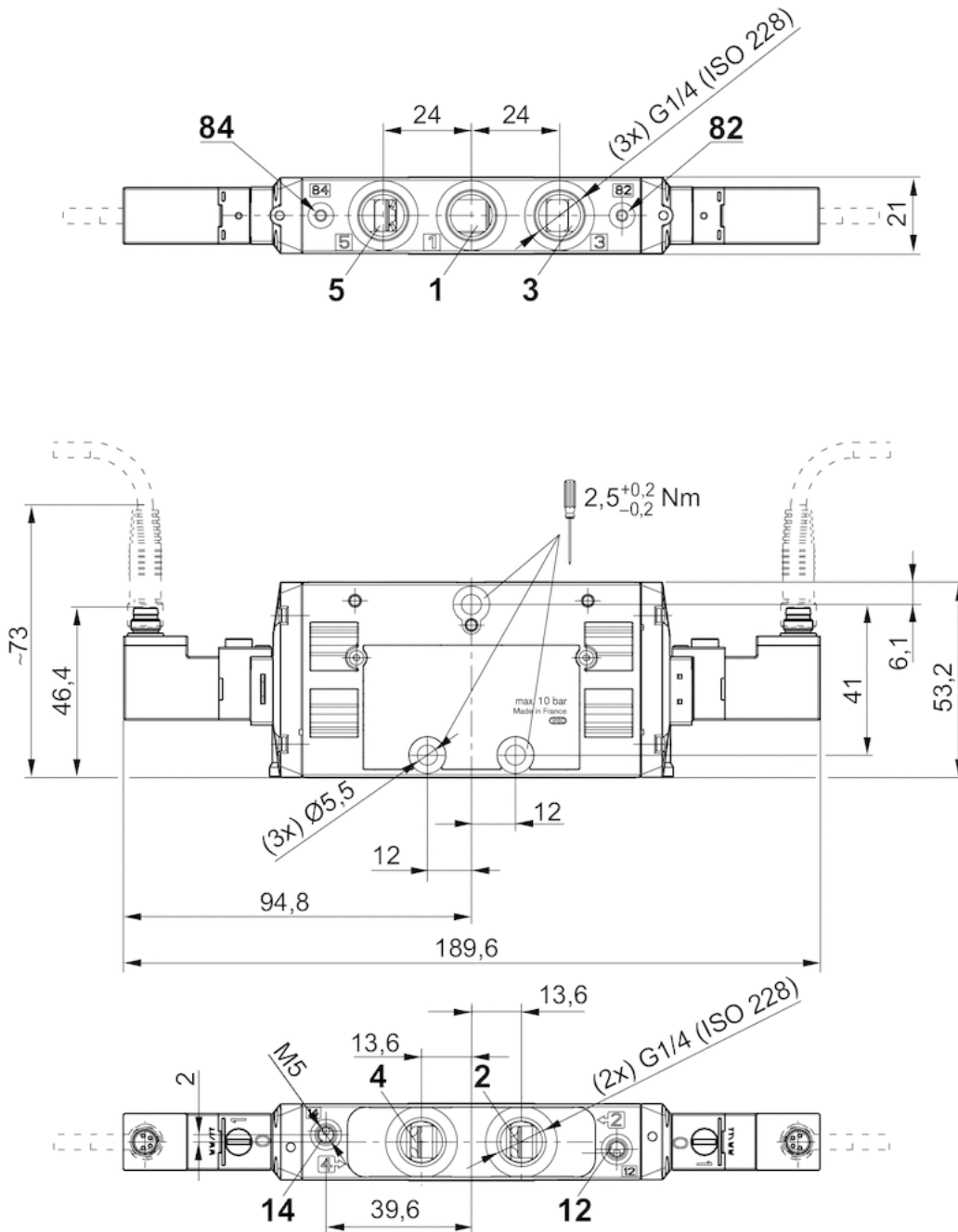

## Pin assignments

### PIN assignment and cable colors for valve plug connectors

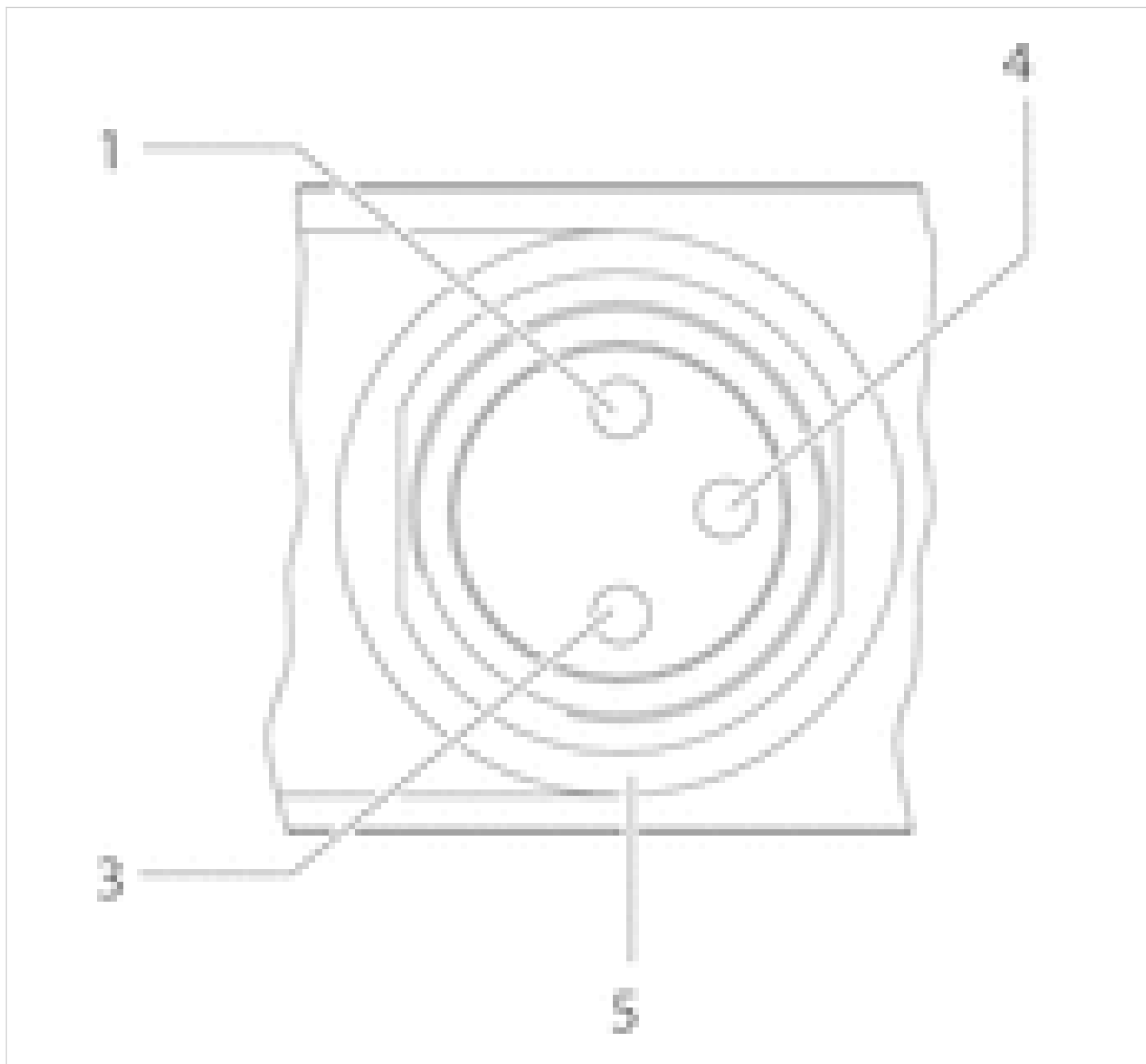

#### PIN assignment:

- 1) PIN not assigned
- 3) 0 V
- 4) 24 V
- 5) LED

#### Cable color

- 1) Brown
- 3) Blue
- 4) Black

Note: Bi-polar protective circuit to prevent overvoltage