

DRAWING FOR REFERENCE: This is subject to change without notice
12/05/2013

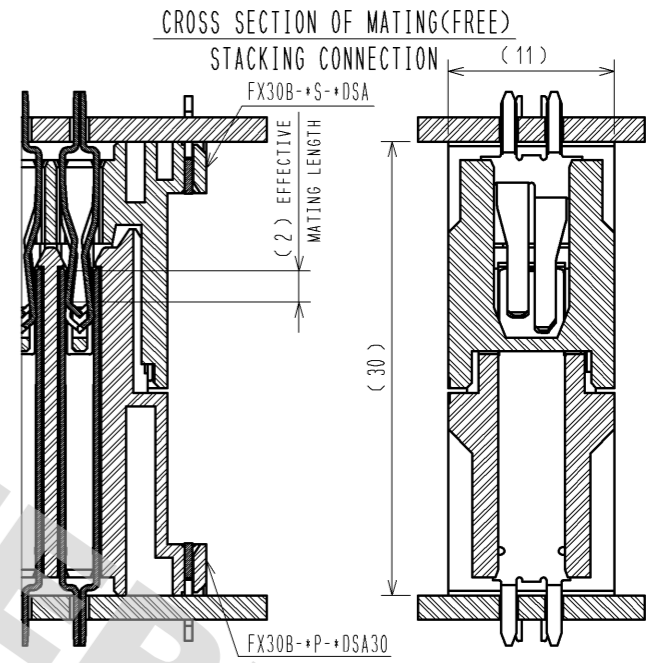
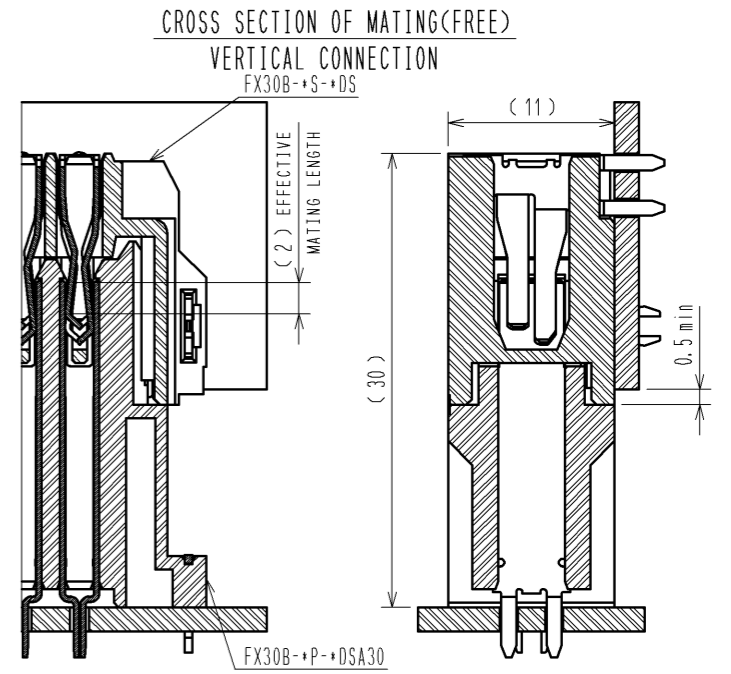
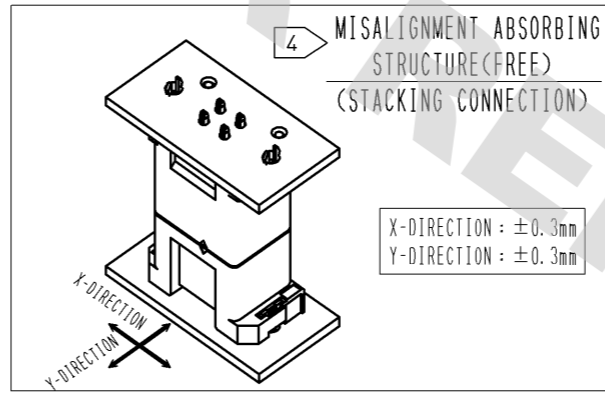
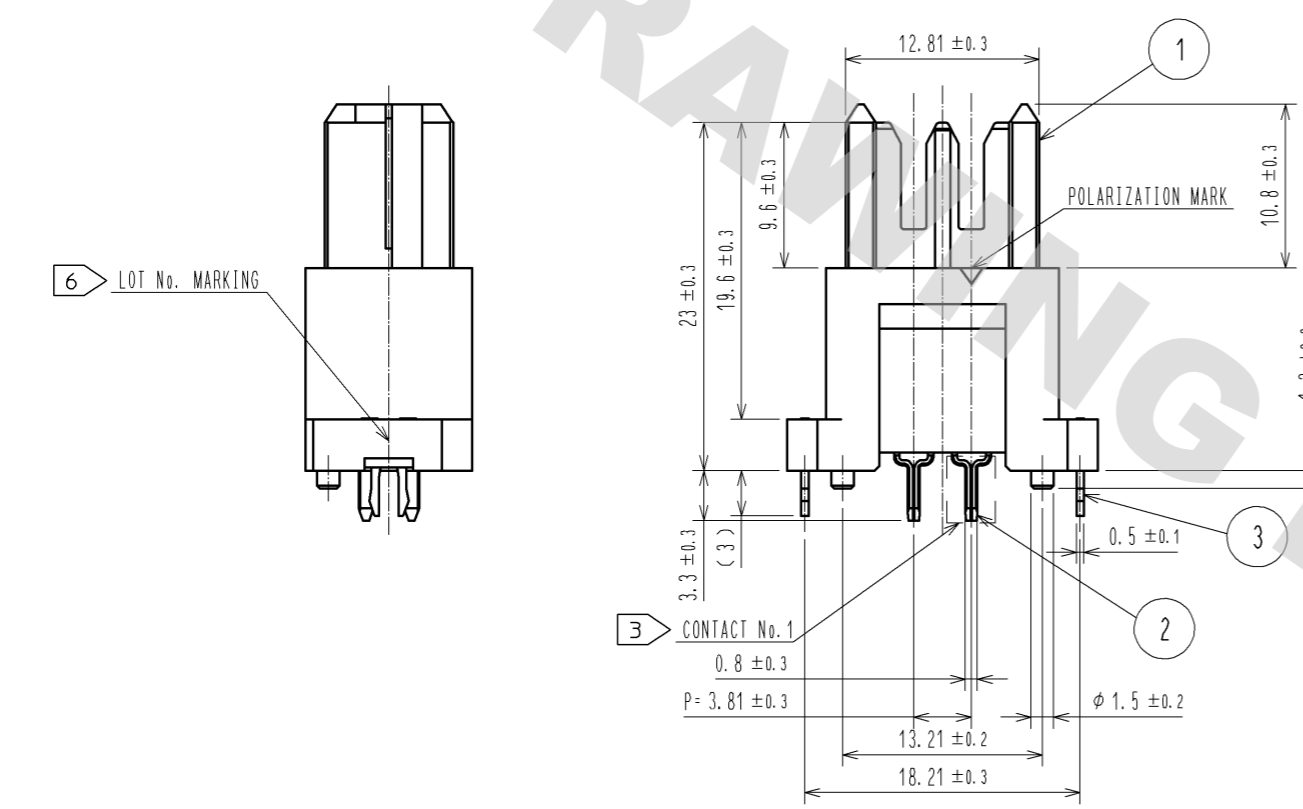
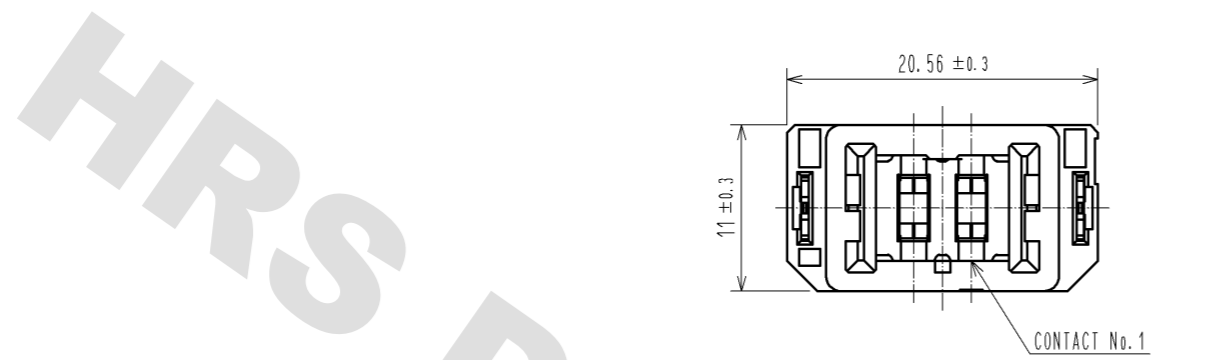

- NOTE
- ① THIS PRODUCT IS PACKAGED IN TRAY. (49pcs/TRAY)
 - ② BLEMISH AND HIT MARK CAN BE OCCURED THROUGH OUT THE MANUFACTURING PROCESS WHICH DOESN'T AFFECT QUALITY LEVEL. ALSO, BLACK SPOT COULD BE OBSERVED ON THE SURFACE OF HOUSING.
 - ③ FOR THE CONTACT NO., ADJACENT TWO PAIRS OF LEADS PLACED BACK-TO-BACK (4 LEADS IN TOTAL) COMPOSE ONE LINE.
 - ④ MISALIGNMENT ABSORBING RANGE: ± 0.3mm max.
 - ⑤ THE DIMENSION IN PARENTHESES ARE FOR REFERENCES.
 - ⑥ LOT NO. IS INDICATED AT EITHER ONE OF THE POSITION AS SHOWN.

2	COPPER ALLOY	CONTACT AREA: GOLD-PLATING 0.1 μm	4	POLYSTYRENE	TIN-PLATING 3.0 μm			
		LEAD AREA: TIN-PLATING 1.0 μm			3	PHOSPHOR BRONZE	UNDER PLATING: NICKEL 1.0 μm	
		UNDER PLATING: NICKEL 1.0 μm					BLACK UL94V-0	
1	POLYAMIDE	BLACK UL94V-0						
NO.	MATERIAL	FINISH . REMARKS	NO.	MATERIAL	FINISH . REMARKS			
UNITS mm		SCALE 2 : 1	COUNT 	DESCRIPTION OF REVISIONS		DESIGNED	CHECKED	DATE
HRS HIROSE ELECTRIC CO., LTD.		APPROVED : HS. OKAWA	13. 03. 07	DRAWING NO.		EDC3-347264-00		
		CHECED : KI. HIROKAWA	13. 03. 07	PART NO.		FX30B-2P-3. 81DSA30		
		DESIGNED : DK. AIMOTO	13. 03. 07	CODE NO.		CL570-3300-2-00		
		DRAWN : DK. AIMOTO	13. 03. 07					

DRAWING FOR REFERENCE: This is subject to change without notice
12/05/2013

RECOMMENDED HOLE PATTERN DIMENSION OF PCB(5:1)
(CONNECTOR MOUNTING SIDE, PCB THICKNESS:t=1.6mm)

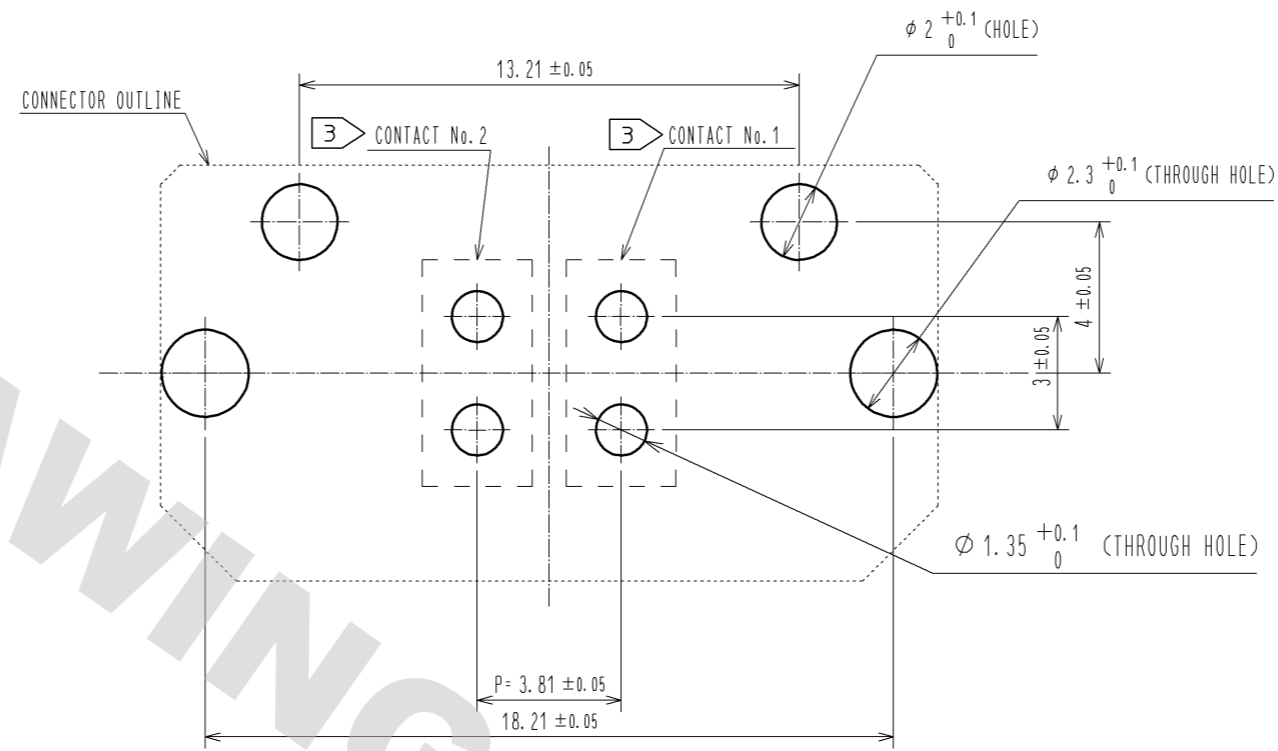

1 DRAWING FOR PACKAGING(1:2)

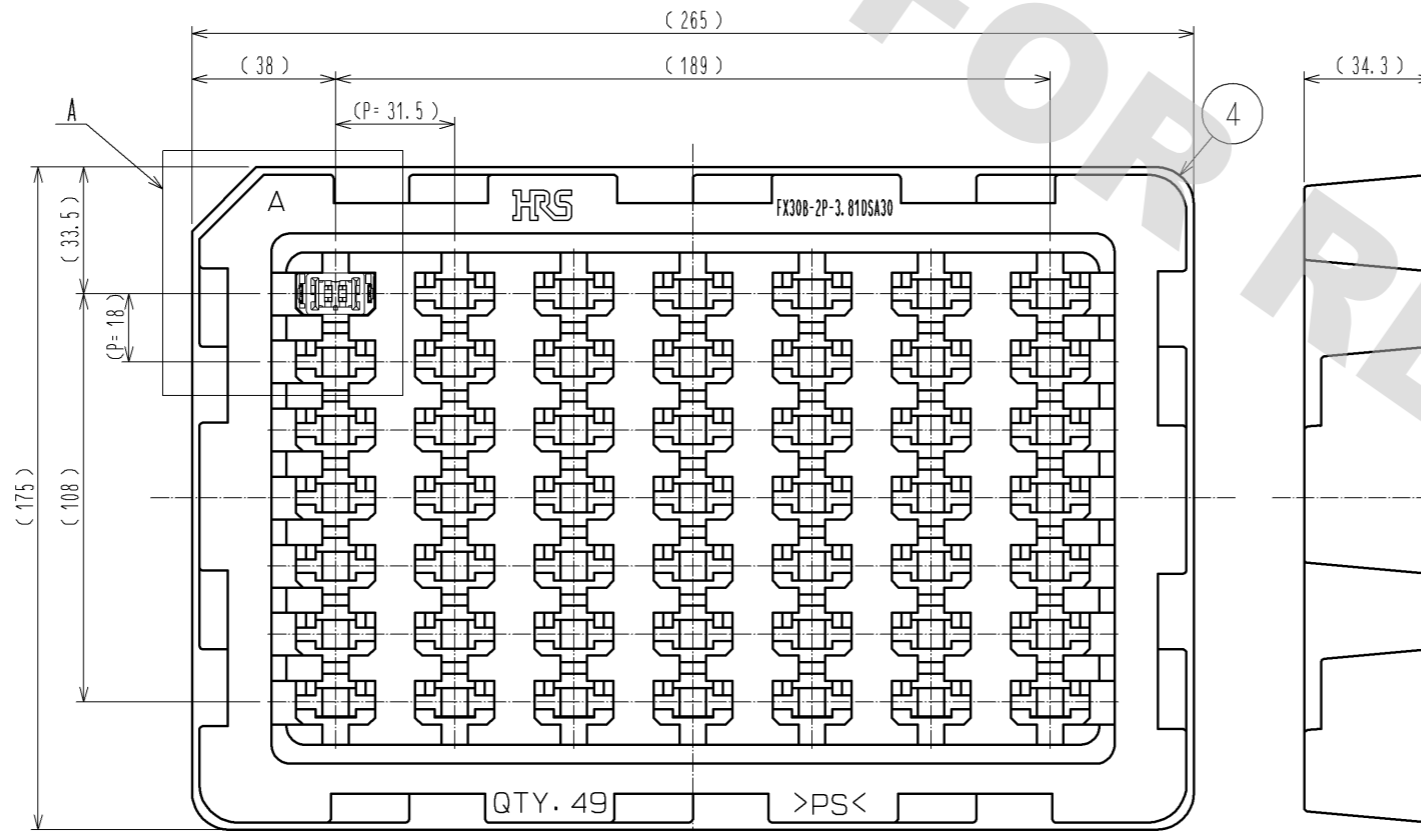

A(1:1)

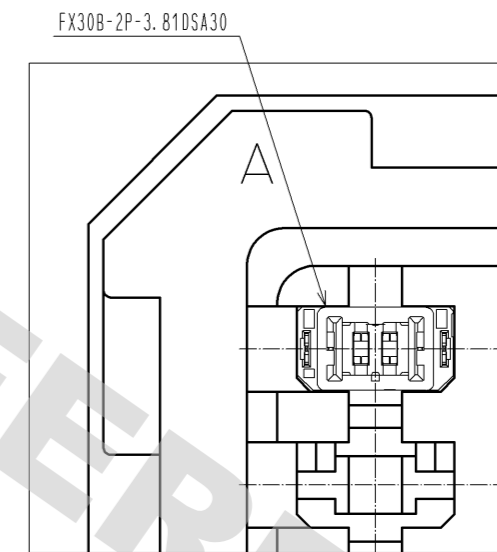

HRS	DRAWING NO.	EDC3-347264-00
	PART NO.	FX30B-2P-3.81DSA30
	CODE NO.	CL570-3300-2-00
	NO.	2/2