

Compact Multiprotocol I/O Module for Ethernet

8 Digital PNP Inputs, Input Diagnostics per Channel

TBEN-S1-8DIP-D

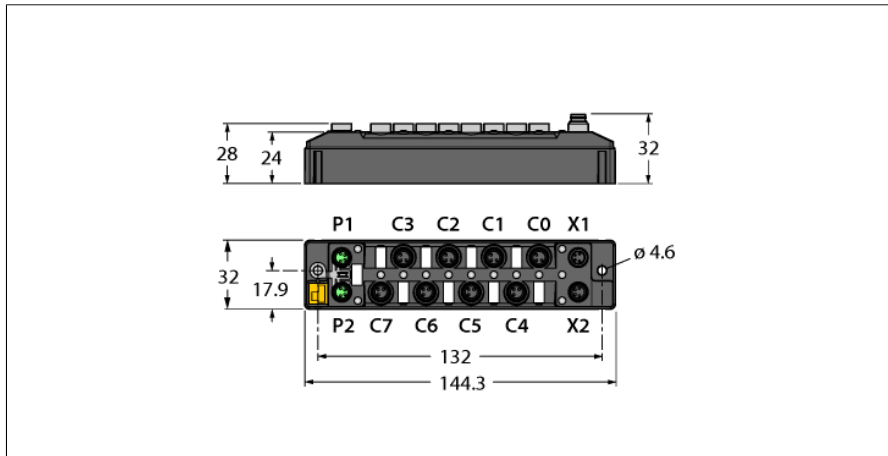

- PROFINET device, EtherNet/IP device or Modbus TCP slave
- Integrated Ethernet switch
- Supports 10 Mbps / 100 Mbps
- 2x M8, 4-pin, Ethernet fieldbus connection
- Glass fiber reinforced housing
- Shock and vibration tested
- Fully potted module electronics
- Protection classes IP65, IP67, IP69K
- M8 connector, 4-pin, for power supply
- Input diagnostics per channel
- FLC/ARGEE programmable

Type designation	TBEN-S1-8DIP-D
Ident no.	6814034
Supply	
Supply voltage	24 VDC
Admissible range	18...30 VDC
	Total current max. 4 A per voltage group V1
Voltage supply connection	2 × M8, 4-pin
Operating current	V1: max. 150 mA
Sensor/Actuator supply V_{aux1}	supply of ports C0-C7 from V1 short-circuit proof, 0.1A per port
Electrical isolation	galvanic isolation of the voltage groups V1 and V2, voltages up to 500 VAC
System data	
Fieldbus transmission rate	10 Mbps/100 Mbps
Fieldbus connection technology	2 × M8, 4-pin
Protocol detection	automatic
Web server	default: 192.168.1.254
Service interface	Ethernet via P1 or P2
Field Logic Controller (FLC)	
ARGEE Firmware Version	3.1.4.0
ARGEE Engineering Version	2.0.24.0
Modbus TCP	
Addressing	Static IP, DHCP
Supported function codes	FC1, FC2, FC3, FC4, FC5, FC6, FC15, FC16, FC23
Number of TCP connections	8
Input register start address	0 (0x0000 hex)
Output register start address	2048 (0x0800 hex)
Ethernet/IP	
Addressing	acc. to EtherNet/IP specification
Quick Connect (QC)	< 500 ms
Device Level Ring (DLR)	supported
Class 3 connections (TCP)	3
Class 1 connections (CIP)	10
Input Assembly Instance	103
Output Assembly Instance	104
Configuration Assembly Instance	106

Compact Multiprotocol I/O Module for Ethernet

8 Digital PNP Inputs, Input Diagnostics per Channel

TBEN-S1-8DIP-D

PROFINET

Addressing	DCP
Conformance class	B (RT)
MinCycleTime	1 ms
Fast Start-Up (FSU)	< 500 ms
Diagnostics	acc. to PROFINET alarm handling
Topology detection	supported
Automatic addressing	supported
Media Redundancy Protocol (MRP)	supported

Digital inputs

Number of channels	8
Connectivity inputs	M8, 3-pin
Input type	PNP
Type of input diagnostics	Channel diagnostics
Switching threshold	EN 61131-2 Typ 3, PNP
Low level signal voltage	< 5 V
High level signal voltage	> 11 V
Low level signal current	< 1.5 mA
High level signal current	> 2 mA
Input delay	0.2ms / 3 ms ms
Electrical isolation	Galvanically isolated to the fieldbus Voltage proof up 500 VDC

Standard/Directive conformity

Vibration test	acceleration to 20 g acc. to EN 60068-2-6
Shock test	acc. to EN 60068-2-27
Drop and topple	acc. to EN 60068-2-31/IEC 60068-2-32
Electromagnetic compatibility	acc. to EN 61131-2
Approvals and certificates	CE, FCC, UV-resistant in accordance with DIN EN ISO 4892-2A (2013)
UL Certificate	cULus LISTED 21 W2, Encl.Type 1 IND.CONT.EQ.

General Information

Dimensions (W x L x H)	32 x 144 x 32mm
Operating temperature	-40...+70 °C
Storage temperature	-40 °C ... +85 °C
Altitude	max. 5000 m
Protection class	IP65 IP67 IP69K
MTTF	287 years acc. to SN 29500 (Ed. 99) 20 °C
Housing material	PA6-GF30
Housing color	Black
Material label	Polycarbonate
Halogen-free	yes
Mounting	2 mounting holes □ 4.6 mm

Note the numbering of the IO range:
From firmware version 3.1.4.0 and higher ports C0 to C7 and channels CH0 to CH7 are counted. The process data image is unchanged. For more details on the corresponding change see manual.

Compact Multiprotocol I/O Module for Ethernet

8 Digital PNP Inputs, Input Diagnostics per Channel

TBEN-S1-8DIP-D

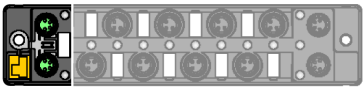
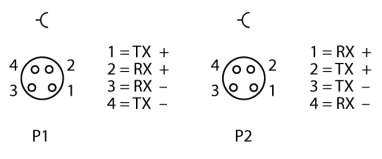
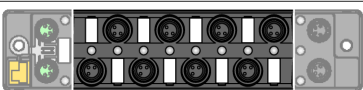
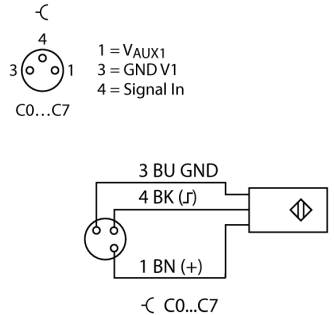
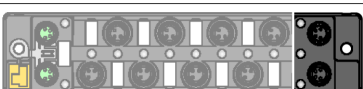
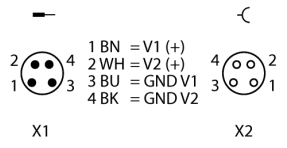
	<p>Note</p> <p>It is strongly recommended to use only ready-made Ethernet cables!</p> <p>Ethernet cable (example):</p> <p>M8-M8: ID number 6630376 PSG4M-0,2-PSG4M/TXN ID number 6934033 PSGS4M-PSGS4M-4416-1M</p> <p>M8-RJ45: ID number 6935342 PSGS4M-RJ45S-4416-1M</p> <p>M8-M12: ID number 6935351 RSSD-PSGS4M-4416-2M</p>	<p>M8 x 1 Ethernet</p> 
	<p>Note</p> <p>Actuator and sensor cable/PUR cable (example):</p> <p>M8 - open end</p> <p>ID No. 6625562 PSG3M-2/TXL</p> <p>M8-M8</p> <p>ID No. 6625665 PKG3M-0,3-PSG3M/TXL</p> <p>ID No. 6627137 PKG3M-3-PSG3M/TXL</p>	<p>M8 x 1 Input</p> 
	<p>Note</p> <p>Power supply cable (example):</p> <p>M8-M8 4 m</p> <p>ID number 6626679 PKG4M-4-PSG4M/TXL</p>	<p>M8 x 1 Voltage Supply</p> 

Compact Multiprotocol I/O Module for Ethernet

8 Digital PNP Inputs, Input Diagnostics per Channel

TBEN-S1-8DIP-D

Module Status LED

LED	Color	Status	Description
ETH1 / ETH2	Green	ON	Ethernet link (100 Mbps)
		flashing	Ethernet communication (100 Mbps)
	Yellow	ON	Ethernet link (10 Mbps)
		flashing	Ethernet communication (10 Mbps)
		OFF	No Ethernet link
BUS	Green	ON	Active connection to a master
		Flashing	Steady flashing: Ready Sequence of 3 flashes in 2 seconds: FLC/ARGEE active
	Red	ON	IP address conflict or Restore Mode or Modbus timeout
		Flashing	Blink/Wink command active
	Red/ Green	Alternating	Waiting for assignment of an IP address, DHCP or BootP
	OFF	Power off	
ERR	Green	On	Diagnostics disabled
	Red	ON	Diagnostics enabled V _u undervoltage diagnosis is parameter-dependent
	LED response master in the Beep network:		
	Green	1 Hz, 250 ms off	Cyclical IO data exchange
	Green/Red	1 Hz, 250 ms red	Cyclical IO data exchange, diagnostics available
	Green/Red	1 Hz, alternating	Discovery mode active
	Red		Discovery mode active, diagnostics available
PWR	Green	ON	Power supply V, OK
		OFF	V, power off or below defined tolerance of 18 V

LED Status I/O

LED	Color	Status	Description
LED 0 ... 7	Green	ON	Input active
	Red	Flashing	Power overload at the corresponding port.
		OFF	Input inactive
LED 7	White	Flashing	Blink/Wink command active

Compact Multiprotocol I/O Module for Ethernet

8 Digital PNP Inputs, Input Diagnostics per Channel

TBEN-S1-8DIP-D

Process Data Mapping of the Single Protocols

For more details on the corresponding protocols see manual.

Modbus TCP

Register Addressing (16-bit)

Offset Process Input Data: 0x0000, structure acc. to general register mapping

Offset Process Output Data: 0x0800: Structure acc. to general register mapping

EtherNet/IP™

Word addressing (16-bit)

Process input data (station -> scanner):

Status word is located in front of the general process data!

	Reg/ Word	Bit 15	Bit 14	Bit 13	Bit 12	Bit 11	Bit 10	Bit 9	Bit 8	Bit 7	Bit 6	Bit 5	Bit 4	Bit 3	Bit 2	Bit 1	Bit 0
GW status	0x0000	-	FCE	-	-	CFG	COM	V1	-	V2	-	-	-	-	-	-	Diag Warn
	0x0001	Structure according to general register mapping															
	...																

Process output data (scanner -> station):

Control word is located in front of the general process data!

	Reg/ Word	Bit 15	Bit 14	Bit 13	Bit 12	Bit 11	Bit 10	Bit 9	Bit 8	Bit 7	Bit 6	Bit 5	Bit 4	Bit 3	Bit 2	Bit 1	Bit 0
Control	0x0000	reserved															
	0x0001	Structure according to general register mapping															
	...																

PROFINET:

Byte addressing (8-bit)

Offset Process Input Data: 0x0000, structure acc. to general register mapping

Offset Process Output Data: 0x0000: Structure acc. to general register mapping

General Register Mapping

Address details are relative. Observe offset of respective protocol

Channel Assignment/Port/Pin:

Channel		-	-	-	-	-	-	-	-	Ch7	Ch6	Ch5	Ch4	Ch3	CH2	CH1	CH0
		-	-	-	-	-	-	-	-	DI7	DI6	DI5	DI4	DI3	DI2	DI1	DI0
Port		-	-	-	-	-	-	-	-	C7	C6	C5	C4	C3	C2	C1	C0
Pin		-	-	-	-	-	-	-	-	P4	P4	P4	P4	P4	P4	P4	P4

Process Input Data:

	Reg/ Word	Byte	Bit 15	Bit 14	Bit 13	Bit 12	Bit 11	Bit 10	Bit 9	Bit 8	Bit 7	Bit 6	Bit 5	Bit 4	Bit 3	Bit 2	Bit 1	Bit 0
			Bit 7	Bit 6	Bit 5	Bit 4	Bit 3	Bit 2	Bit 1	Bit 0	Bit 7	Bit 6	Bit 5	Bit 4	Bit 3	Bit 2	Bit 1	Bit 0
			MSB								LSB							
Digital Inputs	0x0000	0x0000	-	-	-	-	-	-	-	-	DI7	DI6	DI5	DI4	DI3	DI2	DI1	DI0
Diagnostics	0x0001	0x0002	-	-	-	-	-	-	-	-	VERR	VERR	VERR	VERR	VERR	VERR	VERR	VERR
											V1C7	V1C6	V1C5	V1C4	V1C3	V1C2	V1C1	V1C0
Latch input	0x0002	0x0004	-	-	-	-	-	-	-	-	DI7	DI6	DI5	DI4	DI3	DI2	DI1	DI0
Counter Ch0	0x0003	0x0006	Counter value LSB															
	0x0004	0x0008	Counter value MSB															
Frequency Ch0	0x0005	0x000A	Frequency MSB								Frequency LSB							
Status	0x0006	0x000C	-	-	-	-	-	-	-	-	Status							
Module Status	0x0007	0x000E	-	FCE	-	-	-	COM	V1	-	V2	-	-	-	-	-	-	DIAG

Process Output Data:

	Reg/ Word	Byte	Bit 15	Bit 14	Bit 13	Bit 12	Bit 11	Bit 10	Bit 9	Bit 8	Bit 7	Bit 6	Bit 5	Bit 4	Bit 3	Bit 2	Bit 1	Bit 0
			Bit 7	Bit 6	Bit 5	Bit 4	Bit 3	Bit 2	Bit 1	Bit 0	Bit 7	Bit 6	Bit 5	Bit 4	Bit 3	Bit 2	Bit 1	Bit 0
			MSB								LSB							
Latch Reset	0x0001	0x0002	-	-	-	-	-	-	-	-	DI7	DI6	DI5	DI4	DI3	DI2	DI1	DI0
Control	0x0002	0x0004	-	-	-	-	-	-	-	-	-	-	-	-	-	-	-	CNT_ RST

Legend:

V1	Undervoltage V1	CFG	I/O configuration error
V2	Undervoltage V2	FCE	I/O-ASSISTANT Force Mode active
Cx	Port x	Px	Pin x
DIx	Digital Input Channel x	DIx	Digital Input Channel x

Compact Multiprotocol I/O Module for Ethernet
8 Digital PNP Inputs, Input Diagnostics per Channel
TBEN-S1-8DIP-D

Diag	Module diagnostics available	ERR x	Overcurrent output channel x
VERRVxCHyz	Overcurrent supply VAUXx channel y to z	PWMOUTERR	Overcurrent PWM output
VERRVxPyCz	Overcurrent supply VAUXx, pin y, port z	VAUXxPyCz	Supply VAUXx, pin y, port z
		CNT_RST	Counter reset