

T500, Tantalum, MnO2 Tantalum, High Temperature, 33 uF, 10%, 35 VDC, SMD, MnO2, Molded, High Temperature, 200C, N/A, 600 mOhms, 7343, Height Max = 4.3mm

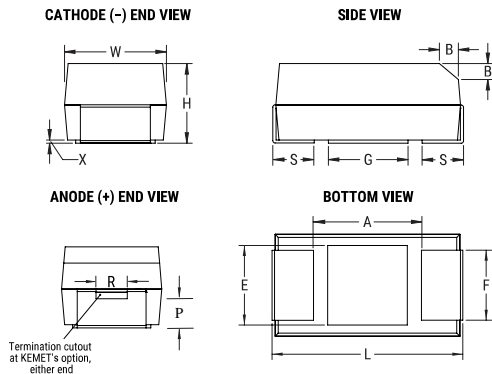

Dimensions	
Footprint	7343
L	7.3mm +/-0.3mm
W	4.3mm +/-0.3mm
H	4mm +/-0.3mm
S	1.3mm +/-0.3mm
F	2.4mm +/-0.1mm
A	3.8mm MIN
B	0.5mm +/-0.15mm
E	3.5mm REF
G	3.5mm REF
P	1.7mm REF
R	1mm REF
X	0.1mm +/-0.1mm

Packaging Specifications	
Packaging:	T&R, 178mm
Packaging Quantity:	500

General Information	
Supplier:	KEMET
Series:	T500
Dielectric:	MnO2 Tantalum
Style:	SMD Chip
Description:	SMD, MnO2, Molded, High Temperature, 200C
Features:	200C
RoHS:	Yes
Termination:	Gold
Notes:	In polarity stripe, at KEMET's option, type may be indicated: no symbol = Standard (or low leakage) MnO2 tantalum chip, O = LowESR T494, R = Low ESR T495, F = Fused T496, HT = 150C rated T498 (or B45196P, B45198P), H = 175C rated T499, H2 = 200C rated T50
Shelf Life:	156 Weeks
MSL:	1

Specifications	
Capacitance:	33 uF
Capacitance Tolerance:	10%
Voltage DC:	35 VDC (85C), 28 VDC (125C), 14 VDC (200C)
Temperature Range:	-55/+200C
Rated Temperature:	85°C
Humidity:	85C, 85% RH, 0 V, 1000 Hours
Dissipation Factor:	8.00% 120Hz 20C
Failure Rate:	N/A
Resistance:	600 mOhms (100kHz 20C)
Ripple Current:	524 mA (100kHz 25C), 210 mA (100kHz 125C), 52 mA (100kHz 200C)
Leakage Current:	11.6 uA (5min 20C)

Statements of suitability for certain applications are based on our knowledge of typical operating conditions for such applications, but are not intended to constitute - and we specifically disclaim - any warranty concerning suitability for a specific customer application or use. This Information is intended for use only by customers who have the requisite experience and capability to determine the correct products for their application. Any technical advice inferred from this Information or otherwise provided by us with reference to the use of our products is given gratis, and we assume no obligation or liability for the advice given or results obtained.