

2 BAY EDGELINE

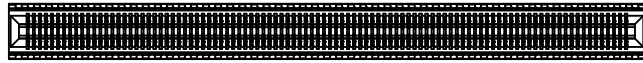

1 BAY EDGELINE

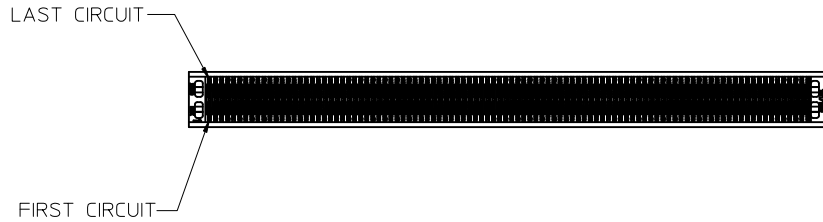
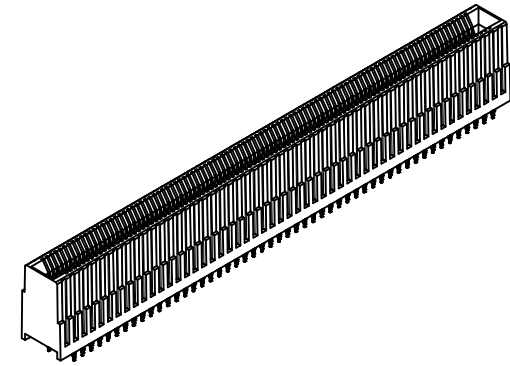
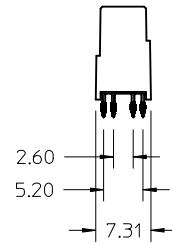
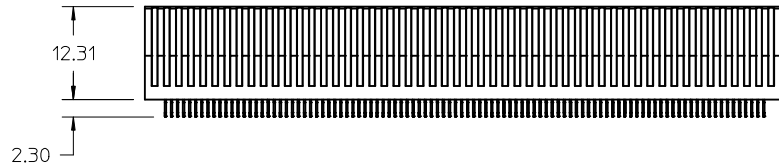

PART NUMBER	VERSION	BAY 1/BAY 2	TOTAL CIRCUITS	DIM A	SALES DRAWING (SEE NOTE 9)
76691-2278	2 BAY	143/132	278	118.63	SD-76691-2278
76691-1200	1 BAY	200	200	84.20	SD-76691-1200
76691-2108	2 BAY	86/22	108	50.63	SD-76691-2108
76691-3108	2 BAY	86/22	108	50.63	SD-76691-3108
76691-2080	2 BAY	52/28	80	39.43	SD-76691-111
76691-9046*	1 BAY	46	46	22.60	SD-76691-109
76691-1046	1 BAY	46	46	22.60	SD-76691-107

NOTES:

- MATERIAL:
HOUSING - GLASS FILLED THERMOPLASTIC, 94-V0, BLACK
TERMINALS - COPPER ALLOY
- FINISH:
CONTACT AREA: HARD GOLD -0.76µm MIN OVER 3.80µ NICKEL
COMPLIANT AREA: TIN - 0.76/1.52µm OVER NICKEL
* SPECIAL FINISH:
CONTACT AREA: HARD GOLD -0.76µm MIN OVER 3.80µ NICKEL
COMPLIANT AREA: TIN-LEAD - 0.76/1.52µm OVER NICKEL
- REFER TO PS-75594-999 PRODUCT SPECIFICATION FOR ALL ELECTRICAL, MECHANICAL AND ENVIRONMENTAL SPECIFICATIONS.
- REFER TO PK-76693-900 FOR ALL PACKAGING SPECIFICATIONS.
- PROCESSING: PRESSFIT TO PC BOARD.
- MATING PC BOARD THICKNESS = 1.60±0.16MM OVER CONTACT PADS.
- PRODUCT IS ELV AND RoHS COMPLIANT. LEVEL OF COMPLIANCE: 6/6
ALL BANNED SUBSTANCES ARE REMOVED:
Pb (LEAD)
HEXAVALENT CHROMIUM (CrVI)
CADMIUM
MERCURY
POLYBROMINATED BIPHENYL (PBB)
POLYBROMINATED DIPHENYL ETHER (PBDE)
- THIS PART CONFORMS TO CLASS B REQUIREMENTS OF COSMETIC SPEC PS-45499-002
- FOR EDGE CARD AND MOUNTING PCB LAYOUT DETAIL SEE CORRESPONDING SALES DRAWING.

REDRAWN DRAWING IEC NO: UCP2011-2702 DRWING: DROSCA 2011/03/07 CHKD: JCOMERCI 2011/03/28 APPR: JCOMERCI 2011/03/28	QUALITY SYMBOLS	GENERAL TOLERANCES (UNLESS SPECIFIED)	DIMENSION STYLE MM ONLY	SCALE 2:1	DESIGN UNITS METRIC	THIRD ANGLE PROJECTION
	▽ = 0	4 PLACES ± --- mm ± --- INCH	DRAWN BY DATE DROSCA 07/21/08	EDGELINE 12.5GB 0.062"PCB 0.8MM PITCH		
	▽ = 0	3 PLACES ± --- mm ± --- INCH	CHECKED BY DATE JCOMERCI 07/21/08			
	▽ = 0	2 PLACES ± 0.13 mm ± --- INCH	APPROVED BY DATE JCOMERCI 2010/10/25	MOLEX INCORPORATED DOCUMENT NO. SD-76691-100		
▽ = 0	1 PLACE ± 0.25 mm ± --- INCH	MATERIAL NO. SEE TABLE	SHEET NO. 1 OF 1			
DRAFT WHERE APPLICABLE MUST REMAIN WITHIN DIMENSIONS		THIS DRAWING CONTAINS INFORMATION THAT IS PROPRIETARY TO MOLEX INCORPORATED AND SHOULD NOT BE USED WITHOUT WRITTEN PERMISSION				

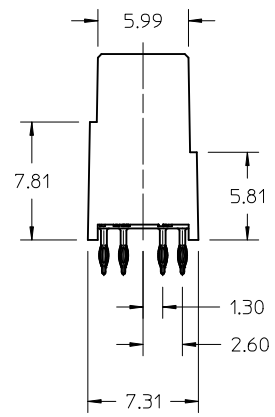
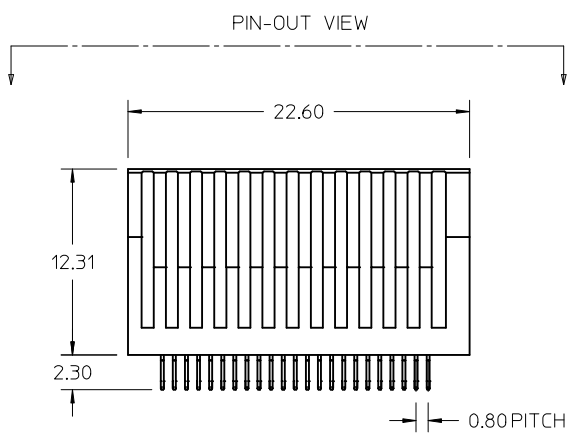
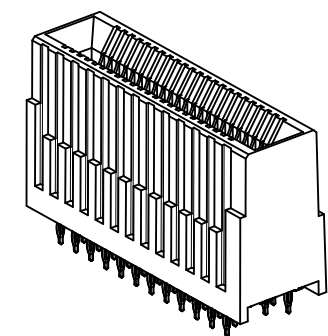
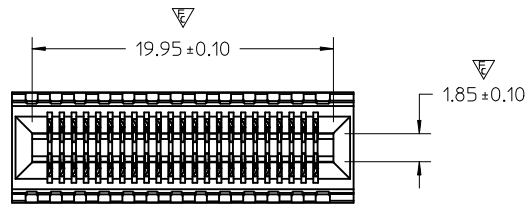

NOTES:

- MATERIAL:
HOUSING - GLASS FILLED THERMOPLASTIC, 94-V0, BLACK
TERMINALS - COPPER ALLOY
- FINISH:
TERMINALS - 0.76 μm MINIMUM GOLD IN THE CONTACT AREA AND 0.76 - 1.52 μm TIN IN PRESSFIT TAIL AREA OVER 1.27 MICRONS MINIMUM NICKEL OVERALL.
- REFER TO PS-76421-001 PRODUCT SPECIFICATION FOR ALL ELECTRICAL, MECHANICAL AND ENVIROMENTAL SPECIFICATIONS.
- REFER TO PK-75594-999 FOR ALL PACKAGING SPECIFICATIONS.
- PROCESSING: PRESSFIT TO PC BOARD.
- IN ORDER TO PROVIDE OPTIMAL ELECTRICAL PERFORMANCE, THE MATING BOARD MUST MEET REQUIREMENTS OF AMC.O R2 SPECIFICATION.
- MATING PC BOARD THICKNESS = 1.60±0.16MM OVER CONTACT PADS.
- PRODUCT IS ELV AND RoHS COMPLIANT. LEVEL OF COMPLIANCE: 6/6
ALL BANNED SUBSTANCES ARE REMOVED:
Pb (LEAD)
HEXAVALENT CHROMIUM (CrVI)
CADMIUM
MERCURY
POLYBRMINATED BIPHENYL (PBB)
POLYBROMINATED DIPHENYL ETHER (PBDE)
- THIS PART CONFORMS TO CLASS B REQUIREMENTS OF COSMETIC SPEC PS-45499-002

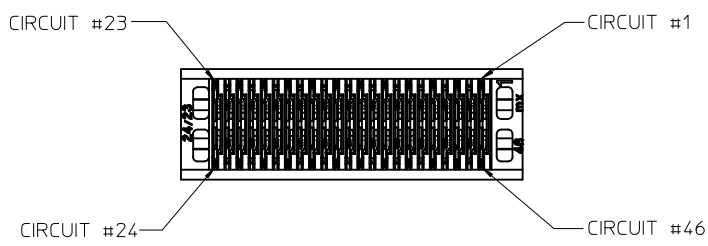

ADDED CIRCUIT # EC NO: UCP2011-2702 DRW: DROSCA 2011/03/23 CHKD: JCOMERCI 2011/03/28 APPR: JCOMERCI 2011/03/28	QUALITY SYMBOLS ∇ = 0 ∇ = 1 ∇ = 1	GENERAL TOLERANCES (UNLESS SPECIFIED) <table border="1"> <tr> <th></th> <th>mm</th> <th>INCH</th> </tr> <tr> <td>4 PLACES</td> <td>± 0.15</td> <td>± 0.006</td> </tr> <tr> <td>3 PLACES</td> <td>± 0.25</td> <td>± 0.010</td> </tr> <tr> <td>2 PLACES</td> <td>± 0.38</td> <td>± 0.015</td> </tr> <tr> <td>1 PLACE</td> <td>± 0.51</td> <td>± 0.020</td> </tr> </table>		mm	INCH	4 PLACES	± 0.15	± 0.006	3 PLACES	± 0.25	± 0.010	2 PLACES	± 0.38	± 0.015	1 PLACE	± 0.51	± 0.020	DIMENSION STYLE MM ONLY DRAWN BY: DROSCA DATE: 12/02/2008 CHECKED BY: JCOMERCI DATE: 12/02/2008 APPROVED BY: JCOMERCI DATE: 12/02/2008	SCALE 4:1 DESIGN UNITS METRIC THIRD ANGLE PROJECTION	TITLE EDGELINE 12.5GB 46CKTS 0.062*PCB 0.8MM PITCH
		mm	INCH																	
	4 PLACES	± 0.15	± 0.006																	
	3 PLACES	± 0.25	± 0.010																	
2 PLACES	± 0.38	± 0.015																		
1 PLACE	± 0.51	± 0.020																		
REV A2	DESCRIPTION DRAFT WHERE APPLICABLE MUST REMAIN WITHIN DIMENSIONS	MATERIAL NO. 766911046	MATERIAL NO. SD-76691-107	SHEET NO. 1 OF 5	MOLEX INCORPORATED															
SIZE THIS DRAWING CONTAINS INFORMATION THAT IS PROPRIETARY TO MOLEX INCORPORATED AND SHOULD NOT BE USED WITHOUT WRITTEN PERMISSION																				
ADDITIONAL INFORMATION: THIS DRAWING CONTAINS INFORMATION THAT IS PROPRIETARY TO MOLEX INCORPORATED AND SHOULD NOT BE USED WITHOUT WRITTEN PERMISSION																				

P.C. BOARD MOUNTING

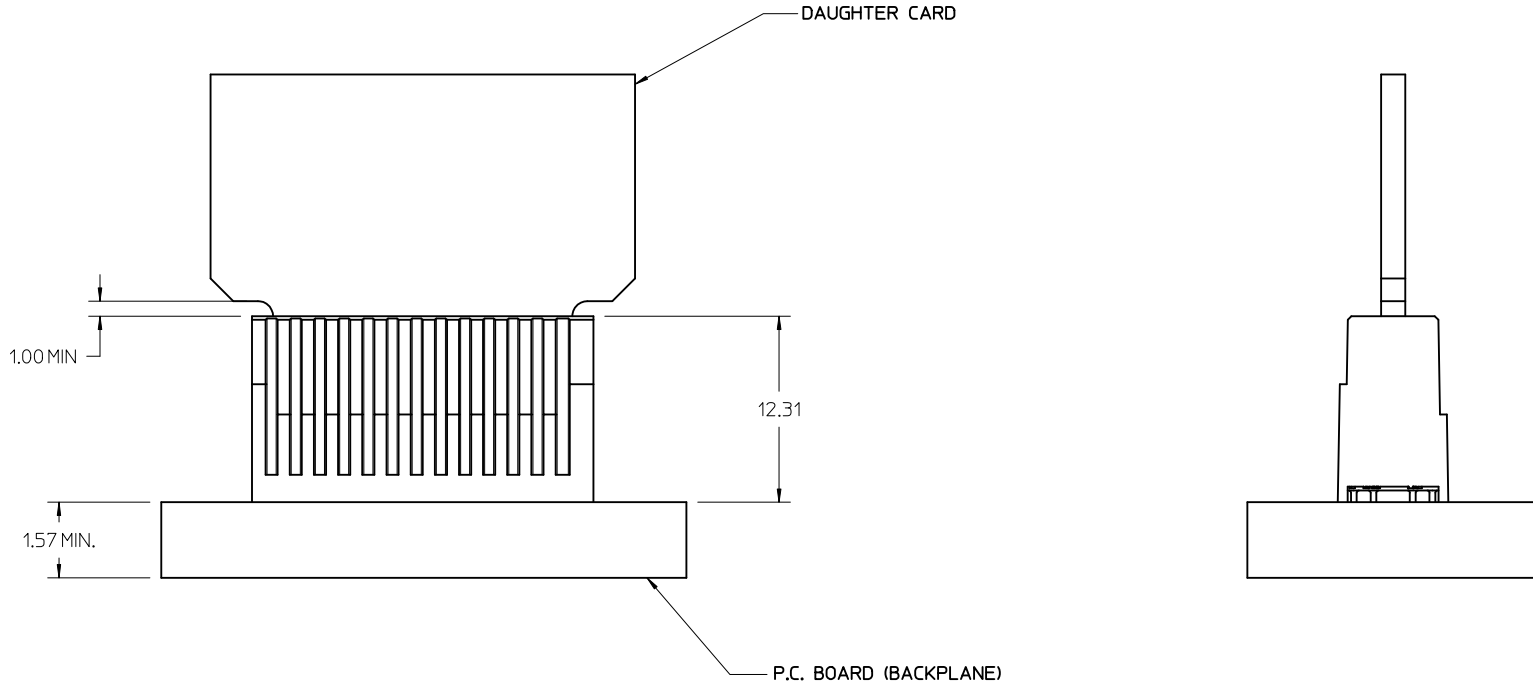
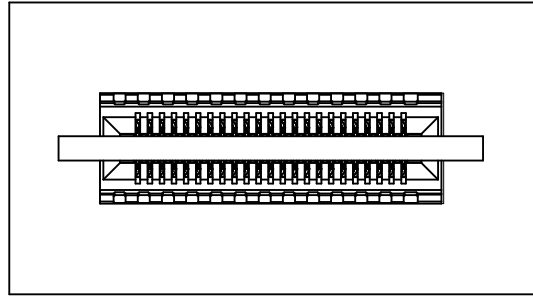

SEE SHEET 1 IEC NO: UCP2011-2702 DRWN: DROSCA 2011/03/23 CHKD: JCOMERC I 2011/03/28 APPR: JCOMERC I 2011/03/28	QUALITY SYMBOLS	▽=0 ▽=0	GENERAL TOLERANCES (UNLESS SPECIFIED)	DIMENSION STYLE MM ONLY	SCALE 4:1	DESIGN UNITS METRIC	THIRD ANGLE PROJECTION																			
	REV	DESCRIPTION	<table border="1" style="width: 100%; border-collapse: collapse;"> <thead> <tr> <th></th> <th>mm</th> <th>INCH</th> </tr> </thead> <tbody> <tr> <td>4 PLACES</td> <td>± .---</td> <td>± .---</td> </tr> <tr> <td>3 PLACES</td> <td>± .---</td> <td>± .---</td> </tr> <tr> <td>2 PLACES</td> <td>± 0.15</td> <td>± .---</td> </tr> <tr> <td>1 PLACE</td> <td>± 0.25</td> <td>± .---</td> </tr> <tr> <td colspan="3" style="text-align: center;">ANGULAR ± 1/2°</td> </tr> </tbody> </table>		mm	INCH	4 PLACES	± .---	± .---	3 PLACES	± .---	± .---	2 PLACES	± 0.15	± .---	1 PLACE	± 0.25	± .---	ANGULAR ± 1/2°			DRAWN BY DATE DROSCA 12/02/2008 CHECKED BY DATE JCOMERC I 12/02/2008 APPROVED BY DATE JCOMERC I 12/02/2008	TITLE	EDGELINE 12.5GB 46CKTS 0.062"PCB 0.8MM PITCH		
		mm	INCH																							
	4 PLACES	± .---	± .---																							
3 PLACES	± .---	± .---																								
2 PLACES	± 0.15	± .---																								
1 PLACE	± 0.25	± .---																								
ANGULAR ± 1/2°																										
A2		DRAFT WHERE APPLICABLE MUST REMAIN WITHIN DIMENSIONS	SEE SHEET 1 SIZE C	MATERIAL NO.	DOCUMENT NO.	MOLEX INCORPORATED SD-76691-107																				
							SHEET NO. 2 OF 5																			

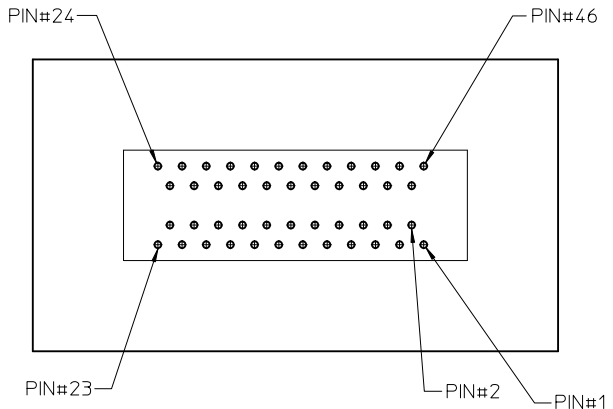
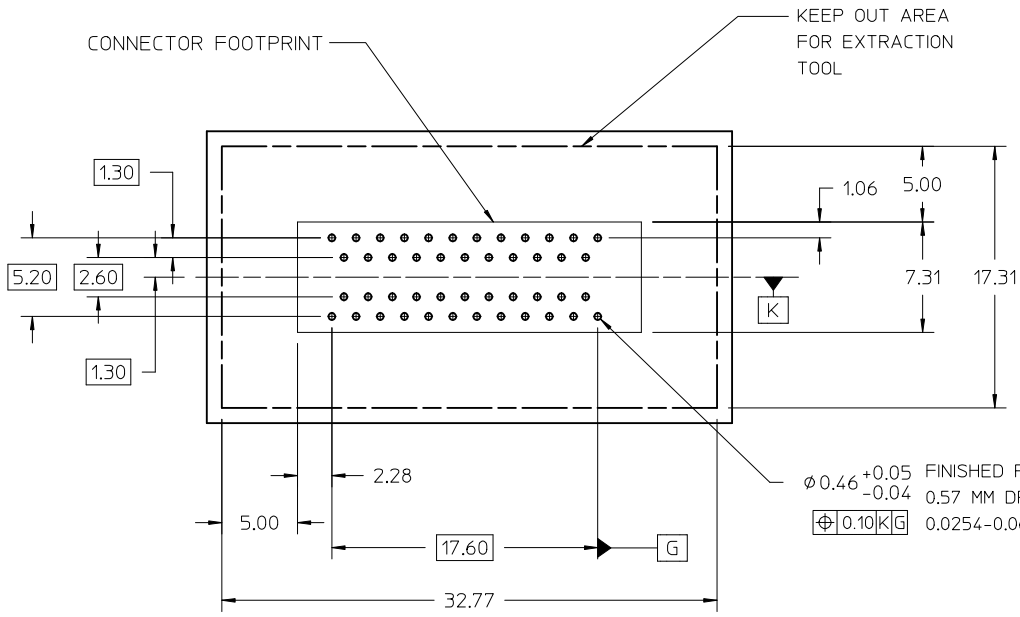

MOTHER BOARD HOLE LAYOUT
(COMPONENT SIDE)

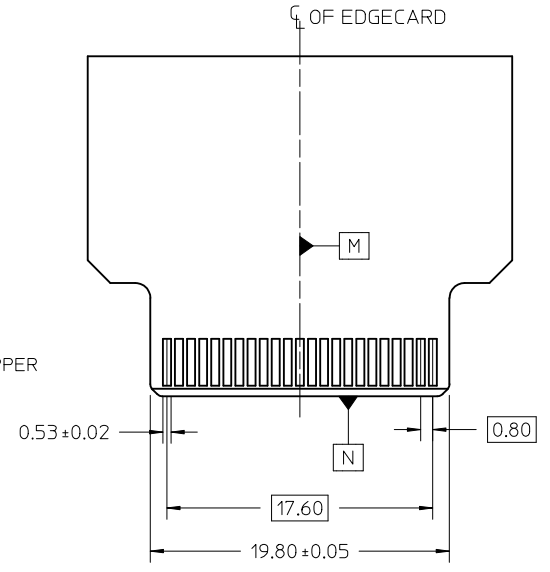

DAUGHTER CARD

SEE SHEET 1 EC NO: UCP2011-2702 DRAWN: DROSCA 2011/03/23 CHKD: JCOMERC I 2011/03/28 APPR: JCOMERC I 2011/03/28	QUALITY SYMBOLS ▽=0 ▽=0	GENERAL TOLERANCES (UNLESS SPECIFIED)		DIMENSION STYLE MM ONLY		SCALE 4:1	DESIGN UNITS METRIC	THIRD ANGLE PROJECTION	
		mm	INCH	DRAWN BY DROSCA	DATE 12/02/2008	TITLE EDGELINE 12.5GB 46CKTS 0.062"PCB 0.8MM PITCH	MATERIAL NO. SD-76691-107		
A2	REV	4 PLACES ± --- ± ---	3 PLACES ± --- ± ---	2 PLACES ± 0.15 ± ---	1 PLACE ± 0.25 ± ---	APPROVED BY JCOMERC I	DATE 12/02/2008	MOLEX INCORPORATED	
		ANGULAR ± 1/2°		DRAFT WHERE APPLICABLE MUST REMAIN WITHIN DIMENSIONS		SEE SHEET 1		DOCUMENT NO. SD-76691-107	SHEET NO. 3 OF 5
THIS DRAWING CONTAINS INFORMATION THAT IS PROPRIETARY TO MOLEX INCORPORATED AND SHOULD NOT BE USED WITHOUT WRITTEN PERMISSION									

MODULE EDGE CARD CONTACT DETAIL

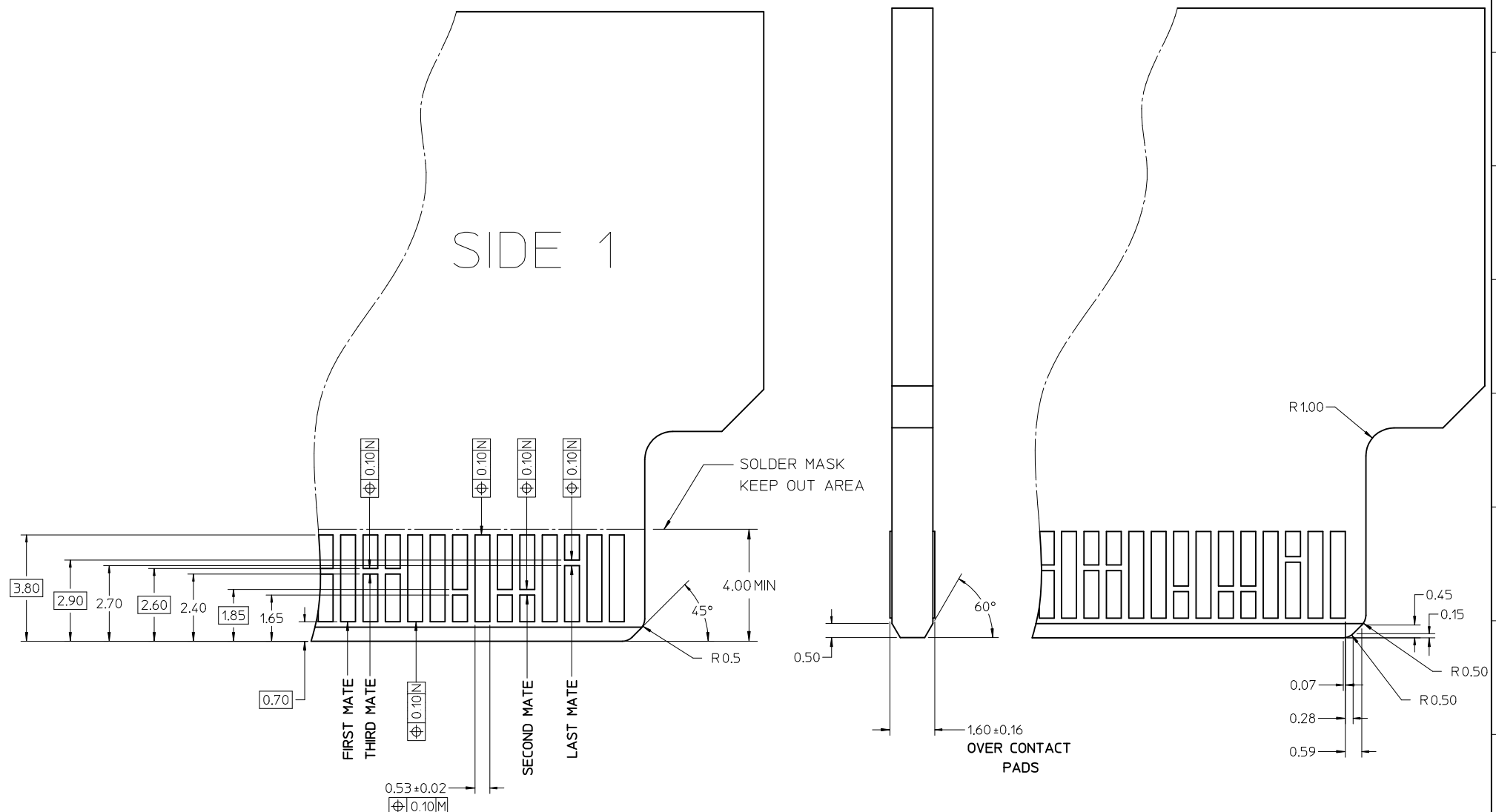

Note:

These are generic details that describe the configuration of various PCB design elements. The customer must determine where and when to use each element to accommodate their specific application.

SEE SHEET 1 EC NO: UCP2011-2702 DRAWN: DROSCA 2011/03/23 CHKD: JCOMERC I 2011/03/28 APPR: JCOMERC I 2011/03/28	QUALITY SYMBOLS ▽=0 ▽=0	GENERAL TOLERANCES (UNLESS SPECIFIED)		DIMENSION STYLE MM ONLY		SCALE 10:1	DESIGN UNITS METRIC	THIRD ANGLE PROJECTION	
		mm	INCH	DRAWN BY DROSCA	DATE 12/02/2008	TITLE EDGELINE 12.5GB 46CKTS 0.062"PCB 0.8MM PITCH			
A2	DESCRIPTION	4 PLACES	± ---	± ---	CHECKED BY JCOMERC I	DATE 12/02/2008	MOLEX INCORPORATED DOCUMENT NO. SD-76691-107		
		3 PLACES	± ---	± ---	APPROVED BY JCOMERC I	DATE 12/02/2008			
		2 PLACES	± 0.15	± ---			SHEET NO. 4 OF 5		
		1 PLACE	± 0.25	± ---	MATERIAL NO.		THIS DRAWING CONTAINS INFORMATION THAT IS PROPRIETARY TO MOLEX INCORPORATED AND SHOULD NOT BE USED WITHOUT WRITTEN PERMISSION		
		ANGULAR ±1/2°		SEE SHEET 1					
DRAFT WHERE APPLICABLE MUST REMAIN WITHIN DIMENSIONS									

LEGEND 46 CIRCUITS / 0.062*PCB

COMPONENT SIDE 1		ALLEGRO PIN NO.				COMPONENT SIDE 2	
PIN NO.	SIGNAL					SIGNAL	PIN NO.
46	GND	○			○	SIGNAL 1	1
45	SATA0_TX_P		○		○	SIGNAL 2	2
44	SATA0_TX_N	○			○	SIGNAL 3	3
43	GND		○		○	SIGNAL 4	4
42	SATA0_RX_N	○			○	SIGNAL 5	5
41	SATA0_RX_P		○		○	SIGNAL 6	6
40	GND	○			○	P5V_STBY1	7
39	SATA1_TX_P		○		○	SIGNAL 7	8
38	SATA1_TX_N	○			○	SIGNAL 8	9
37	GND		○		○	SIGNAL 9	10
36	SATA1_RX_N	○			○	SIGNAL 10	11
35	SATA1_RX_P		○		○	SIGNAL 11	12
34	GND	○			○	SIGNAL 12	13
33	SATA2_TX_P		○		○	SIGNAL 13	14
32	SATA2_TX_N	○			○	SIGNAL 14	15
31	GND		○		○	P5V_STBY2	16
30	SATA2_RX_N	○			○	SIGNAL 15	17
29	SATA2_RX_P		○		○	SIGNAL 16	18
28	GND	○			○	GND	19
27	SATA3_TX_P		○		○	SATA3_RX_P	20
26	SATA3_TX_N	○			○	SATA3_RX_N	21
25	GND		○		○	GND	22
24	RESERVE	○			○	RESERVE	23

SEE SHEET 1 IEC NO: UCP2011-2702 DRW: DROSCA 2011/03/23 CHKD: JCOMERCI 2011/03/28 APPR: JCOMERCI 2011/03/28	QUALITY SYMBOLS ▼=0 ▽=0	GENERAL TOLERANCES (UNLESS SPECIFIED) <table border="1"> <tr><th></th><th>mm</th><th>INCH</th></tr> <tr><td>4 PLACES</td><td>± .005</td><td>± .0004</td></tr> <tr><td>3 PLACES</td><td>± .005</td><td>± .0004</td></tr> <tr><td>2 PLACES</td><td>± 0.15</td><td>± .005</td></tr> <tr><td>1 PLACE</td><td>± 0.25</td><td>± .010</td></tr> </table> ANGULAR ±1/2°		mm	INCH	4 PLACES	± .005	± .0004	3 PLACES	± .005	± .0004	2 PLACES	± 0.15	± .005	1 PLACE	± 0.25	± .010	DIMENSION STYLE MM ONLY DRAWN BY DATE DROSCA 12/02/2008 CHECKED BY DATE JCOMERCI 12/02/2008 APPROVED BY DATE JCOMERCI 12/02/2008	SCALE 4:1 DESIGN UNITS METRIC THIRD ANGLE PROJECTION	TITLE EDGELINE 12.5GB 46CKTS 0.062*PCB 0.8MM PITCH
		mm	INCH																	
	4 PLACES	± .005	± .0004																	
	3 PLACES	± .005	± .0004																	
2 PLACES	± 0.15	± .005																		
1 PLACE	± 0.25	± .010																		
DRAFT WHERE APPLICABLE MUST REMAIN WITHIN DIMENSIONS	MATERIAL NO. SEE SHEET 1	MOLEX INCORPORATED	SHEET NO. 5 OF 5																	
THIS DRAWING CONTAINS INFORMATION THAT IS PROPRIETARY TO MOLEX INCORPORATED AND SHOULD NOT BE USED WITHOUT WRITTEN PERMISSION	DOCUMENT NO. SD-76691-107																			