

REVISIONS					
P	LTR	DESCRIPTION	DATE	DWN	APVD
A		INITIAL RELEASE	09JUL2025	WB	SA

NOTES:
 1.MATERIAL:
 HOUSING:HIGH TEMP THERMO PLASTIC
 UL94V-0 LCPE4711
 CONTACT:COPPER ALLOY
 SOLDER PEG:COPPER ALLOY
 2.FINISH:
 UNDERPLATED:30U".NICKEL ALL OVER
 CONTACT MATING AREA:AU 8U"
 SOLDER AREA:GOLD FLASH.

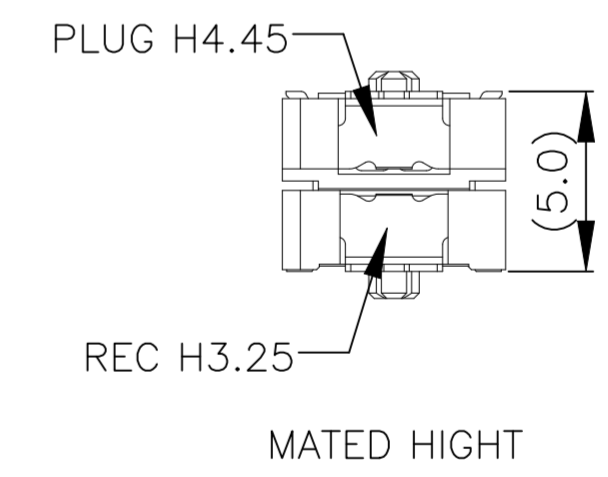
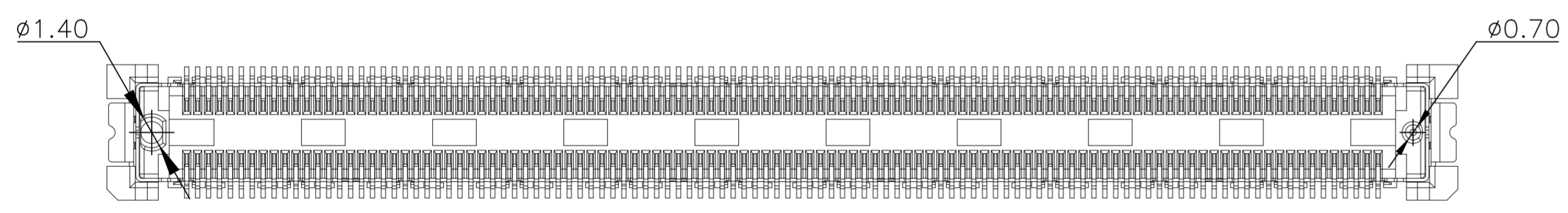
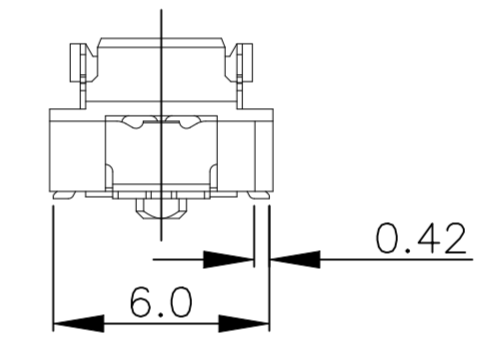
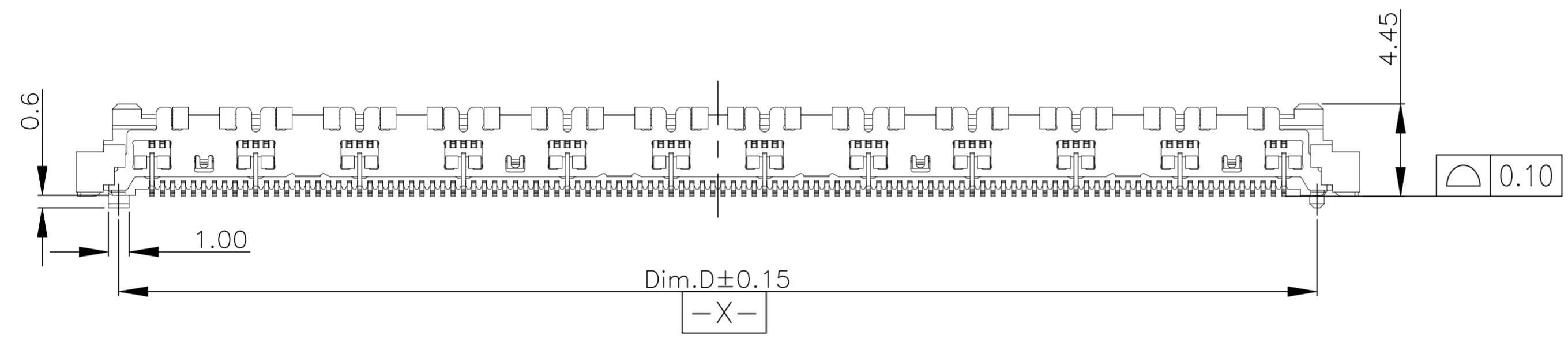
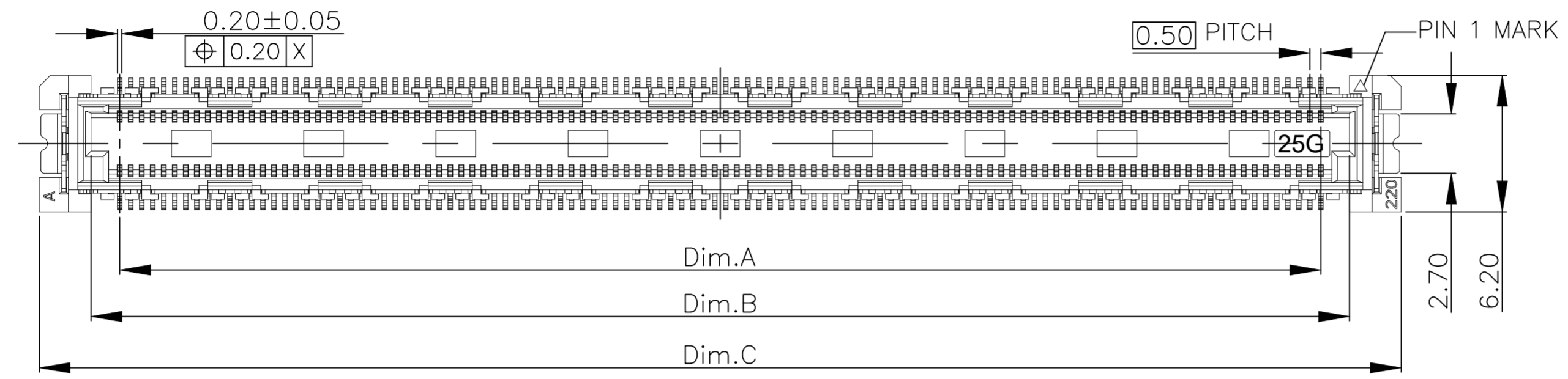

220	2499526-5	54.50	57.10	61.80	57.70
160	2499526-4	39.50	42.10	46.80	42.70
120	2499526-3	29.50	32.10	36.80	32.80
80	2499526-2	19.50	22.10	26.80	22.70
40	2499526-1	9.50	12.10	16.80	12.70
PIN NO	TE PN's	DIM 'A'	DIM 'B'	DIM 'C'	DIM 'D'

THIS DRAWING IS A CONTROLLED DOCUMENT.

DWN	MANOJ K	13DEC2024	TE Connectivity
CHK	GOWTHAM CHITTY	13DEC2024	
APVD	JAGRUTI MOHANTY	13DEC2024	
NAME			
PRODUCT SPEC	108-161908		0.5 BTB Plug H4.45
APPLICATION SPEC	114-161404		
SIZE	A2	00779	DRAWING NO
WEIGHT	1	2499526	RESTRICTED TO
CUSTOMER DRAWING	SCALE 1:1		SHEET 1 OF 10 REV A

2499526

REVISIONS				
P	LTR	DESCRIPTION	DATE	APVD
-	-	SEE SHEET 1	-	-

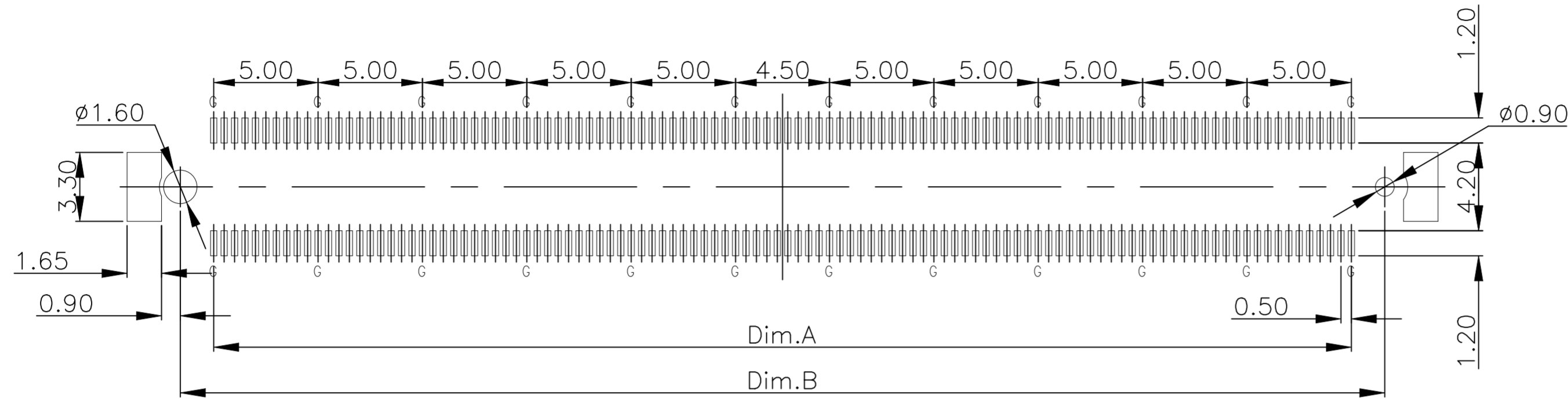

REFERENCE P.C.B LAYOUT

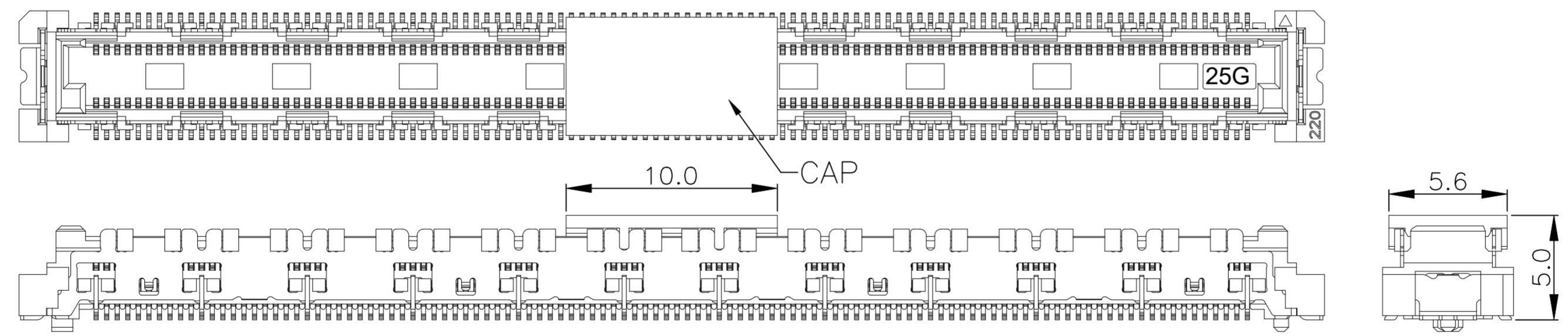

WITH CAP

CAP	220	2499526-5
	160	2499526-4
	120	2499526-3
	80	2499526-2
	40	2499526-1
PICK MODE	PIN NO.	PART NO

THIS DRAWING IS A CONTROLLED DOCUMENT.		DWN MANOJ K 13DEC2024	TE Connectivity	
		CHK GOWTHAM CHITTY 13DEC2024		
		APVD JAGRUTI MOHANTY 13DEC2024	NAME	
		PRODUCT SPEC 108-161908	0.5 BTB Plug H4.45	
		APPLICATION SPEC 114-161404	SIZE A2	CAGE CODE 00779
		WEIGHT 1	DRAWING NO G-2499526	RESTRICTED TO -
MATERIAL SEE NOTE		FINISH SEE NOTE	CUSTOMER DRAWING	SCALE 1:1 SHEET 2 OF 10 REV A

2499526

REVISIONS				
P	LTR	DESCRIPTION	DATE	APVD
-	-	SEE SHEET 1	-	-

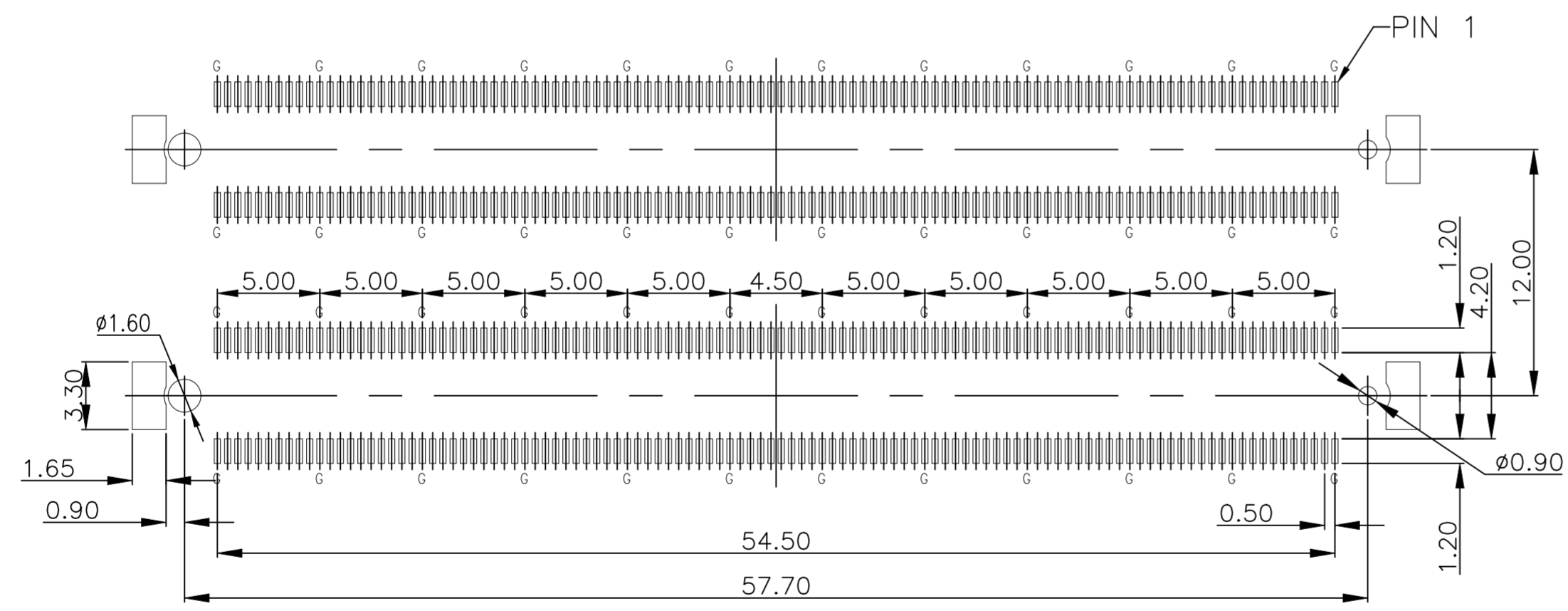
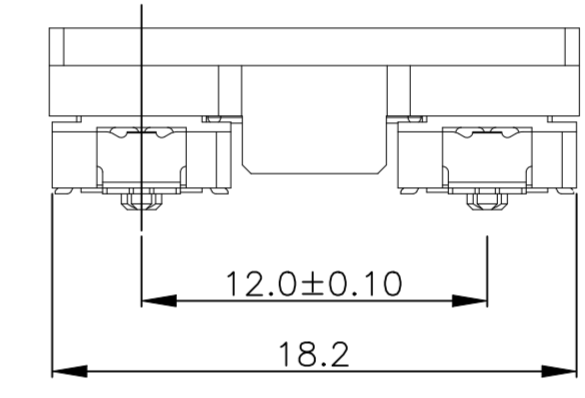
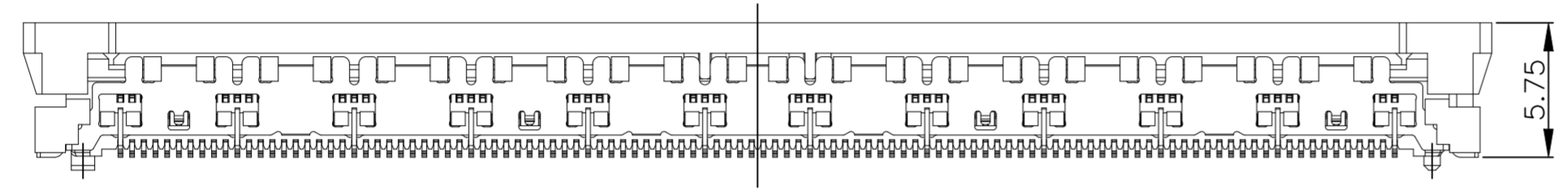
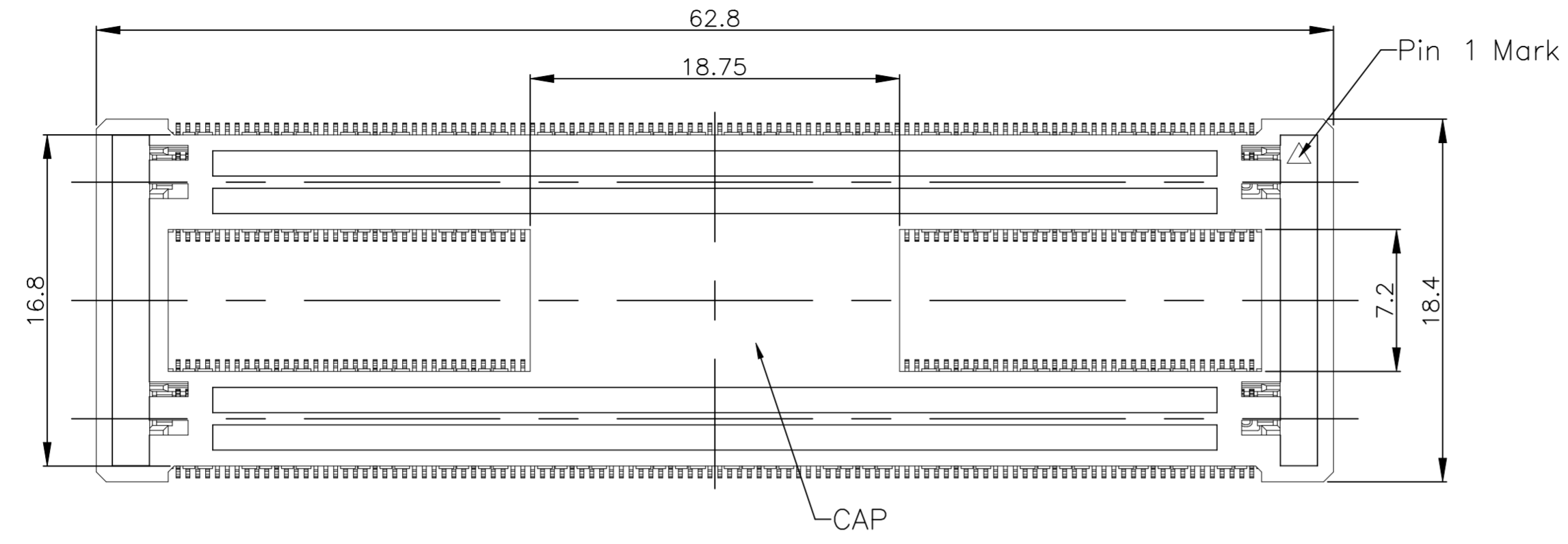

REFERENCE P.C.B LAYOUT

ABOVE SHOWN 440 PINS(2495526-6)

2495526-6	440
PART NO.	PIN NO.

THIS DRAWING IS A CONTROLLED DOCUMENT.		DWN MANOJ K 13DEC2024	TE Connectivity	
DIMENSIONS: mm		CHK GOWTHAM CHITTY 13DEC2024		
TOLERANCES UNLESS OTHERWISE SPECIFIED:		APVD JAGRUTI MOHANTY 13DEC2024	NAME 0.5 BTB Plug H4.45	
0 PLC ± 0.50 1 PLC ± 0.20 2 PLC ± 0.10 3 PLC ± 0.05 4 PLC ± 0.05 ANGLES ± 3°		PRODUCT SPEC 108-161908	SIZE A2	CAGE CODE 00779
MATERIAL SEE NOTE		APPLICATION SPEC 114-161404	DRAWING NO G-2499526	RESTRICTED TO -
WEIGHT 1		CUSTOMER DRAWING		SCALE 1:1
		SHEET 3 OF 10		REV A

2499526

REVISIONS				
P	LTR	DESCRIPTION	DATE	APVD
-	-	SEE SHEET 1	-	-

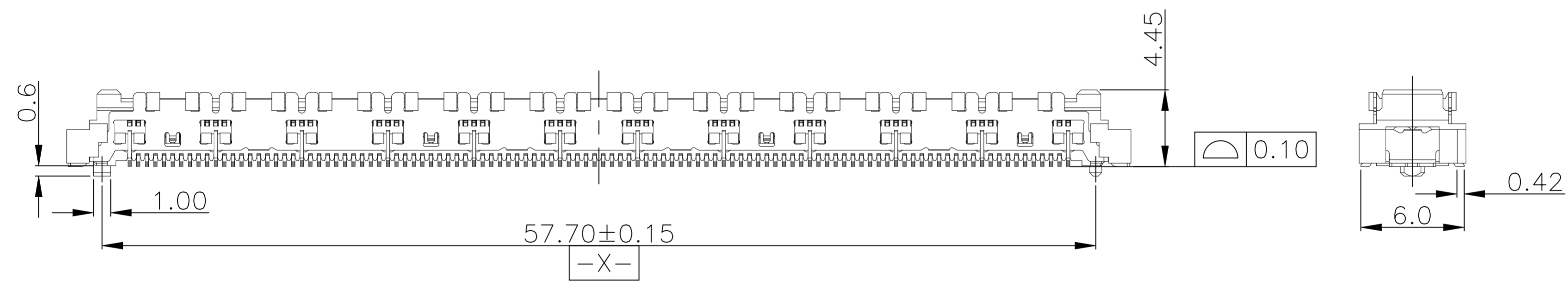
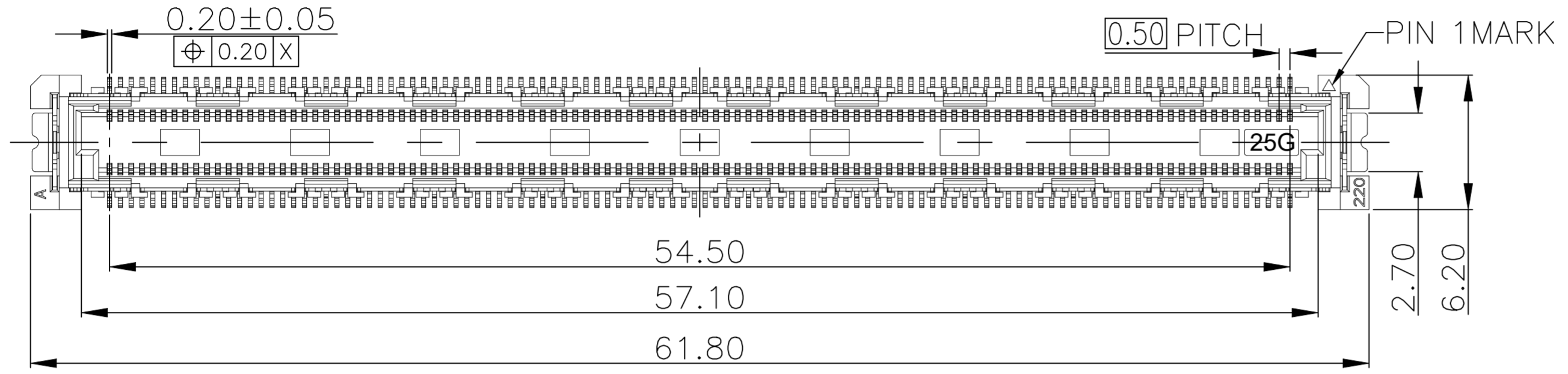

ABOVE SHOWN 440 PINS(2495526-6)

THIS DRAWING IS A CONTROLLED DOCUMENT.		DWN MANOJ K 13DEC2024	TE Connectivity	
DIMENSIONS: mm		CHK GOWTHAM CHITTY 13DEC2024		
TOLERANCES UNLESS OTHERWISE SPECIFIED: 0 PLC ± 0.50 1 PLC ± 0.20 2 PLC ± 0.10 3 PLC ± 0.05 4 PLC ± 0.05 ANGLES ± 3°		APVD JAGRUTI MOHANTY 13DEC2024	NAME -	
MATERIAL SEE NOTE		FINISH SEE NOTE	PRODUCT SPEC 108-161908	
		APPLICATION SPEC 114-161404	SIZE A2	CAGE CODE 00779
		WEIGHT 1	DRAWING NO G-2499526	RESTRICTED TO -
		CUSTOMER DRAWING	SCALE 1:1	SHEET 4 OF 10
			REV A	

2499526

REVISIONS					
P	LTR	DESCRIPTION	DATE	DWN	APVD
-	-	SEE SHEET 1	-	-	-

NOTES:

- CORRECTLY PLACED, THE TRIANGLE SYMBOL OF THE TRAY DISK IS PLACED IN THE UPPER LEFT CORNER; THE TRIANGLE SYMBOL ON THE PRODUCT IS PIN 1, WHICH CORRESPONDS TO THE TRIANGLE IN THE UPPER LEFT CORNER OF THE TRAY DISK IN THE SAME DIRECTION, AND THE ANTI MIS-OPERATION PORT IS IN THE SAME DIRECTION AS THE TRAY ANTI MIS-OPERATION PORT.
- THE ENTIRE TRAY IS FILLED WITH PRODUCTS, AND THE TRAY IS STACKED IN THE SAME DIRECTION. 20 TRAYS OF PRODUCTS PLUS 1 EMPTY TRAY FORM 1 BUNDLE, WITH LABELS ATTACHED TO THE EMPTY TRAYS. PE FILM IS USED TO CROSS WRAP AT LEAST 2 TURNS (WIDTH 60MM) AS SHOWN IN FIGURE 2.

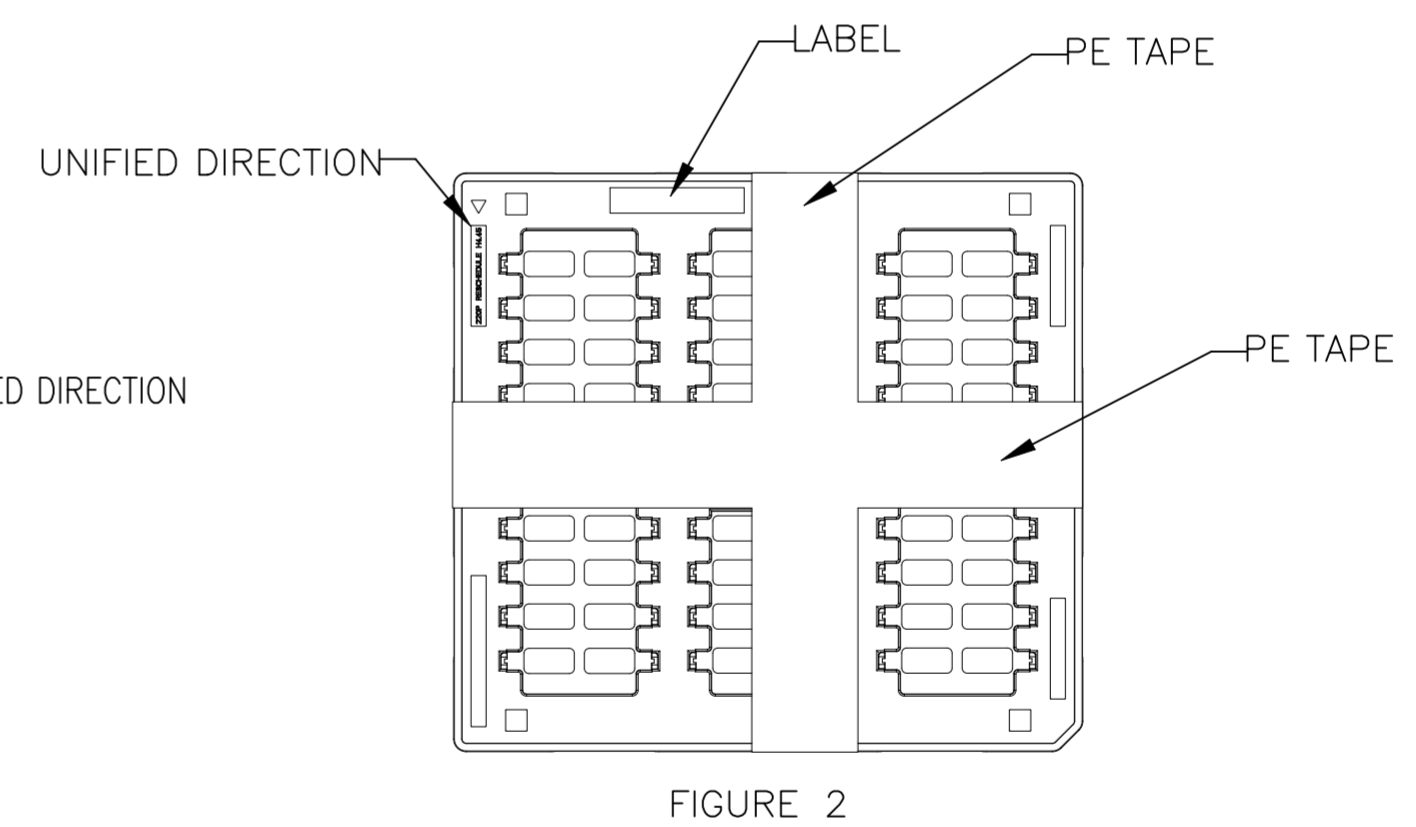
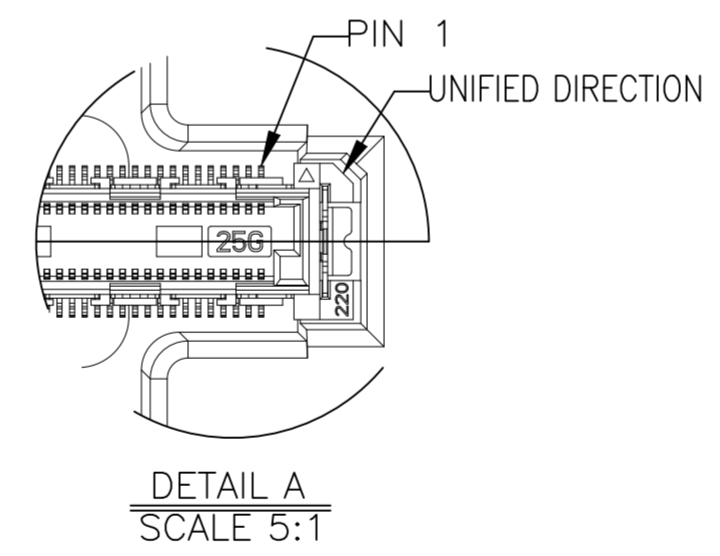
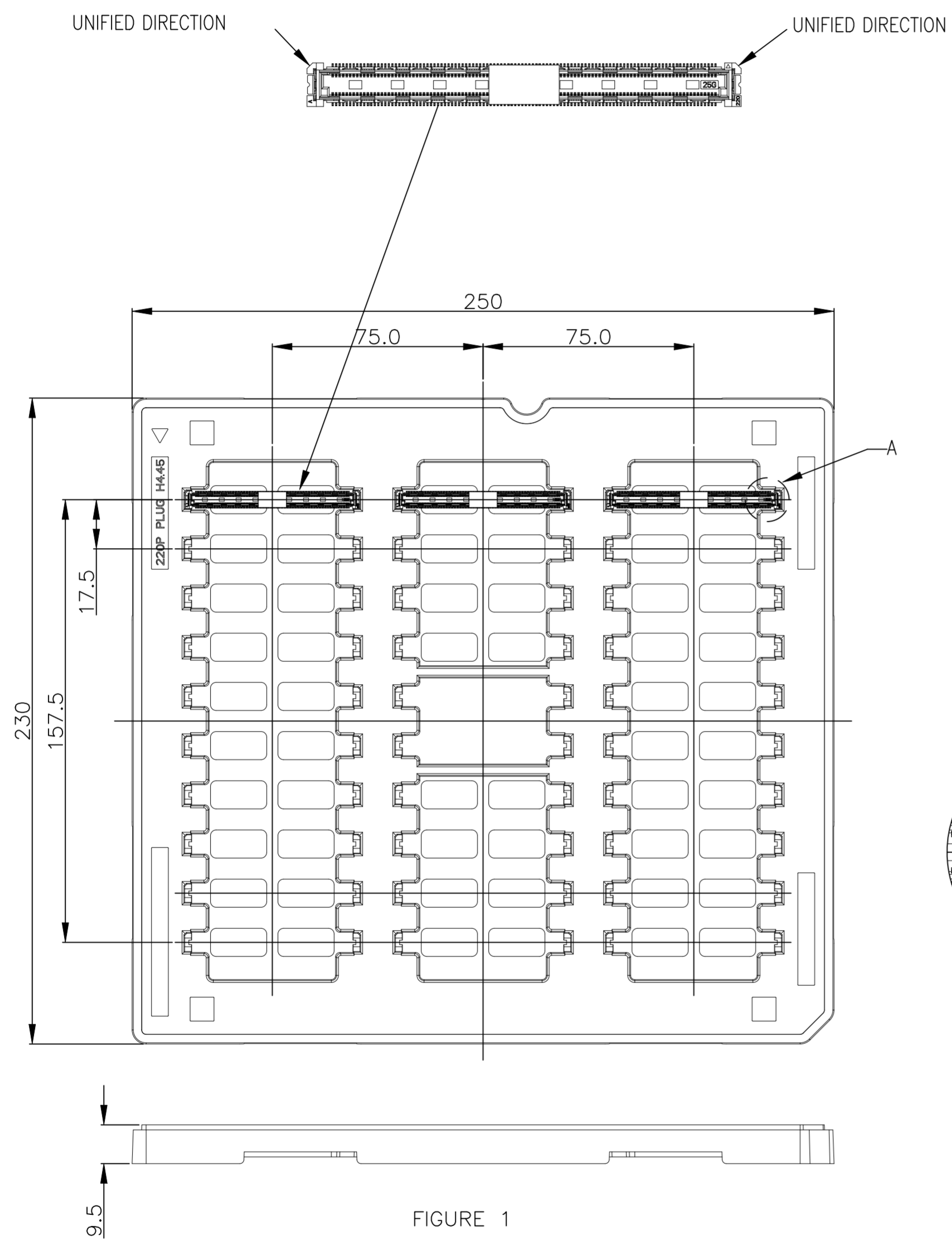

2499526

THIS DRAWING IS A CONTROLLED DOCUMENT.		DWN MANOJ K 13DEC2024	TE Connectivity	
DIMENSIONS: mm		CHK GOWTHAM CHITTY 13DEC2024		
TOLERANCES UNLESS OTHERWISE SPECIFIED:		APVD JAGRUTI MOHANTY 13DEC2024	NAME -	
0 PLC ± 0.50		PRODUCT SPEC	-	
1 PLC ± 0.20		108-161908	0.5 BTB Plug H4.45	
2 PLC ± 0.10		APPLICATION SPEC	-	
3 PLC ± 0.05		114-161404	SIZE A2	CAGE CODE 00779
4 PLC ±		1	DRAWING NO 2499526	RESTRICTED TO -
ANGLES ± 3'		CUSTOMER DRAWING	SCALE 1:1	SHEET 5 of 10
MATERIAL SEE NOTE	FINISH SEE NOTE	WEIGHT 1	REV A	

REVISIONS				
P	LTR	DESCRIPTION	DATE	APVD
-	-	SEE SHEET 1	-	-

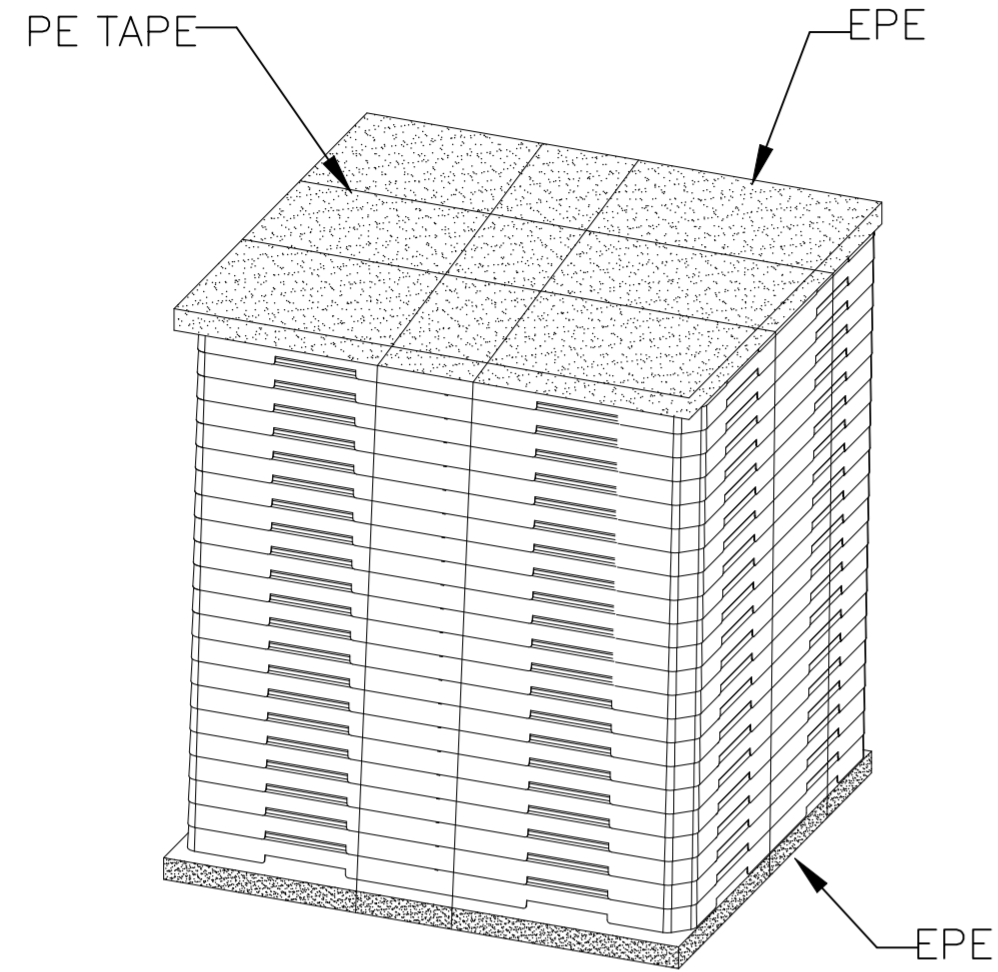

- NOTES:
1. WATERPROOF BAGS NEED TO BE TAPED TIGHTLY AND SEALED. IF THERE ARE ANY UNFILLED BOXES, THEY MUST BE FILLED WITH CUSHIONING MATERIALS
 2. FILL THE OUTER BOX WITH FINISHED PRODUCTS, MAXIMUM NUMBER OF STACKED BOXES: 5 BOXES
 3. WRAP THE WHOLE BUNDLE OF PRODUCTS FIRMLY WITH PE FILM.
 4. PLACE ONE PEARL AT THE BOTTOM OF THE BOX, AND ONE PEARL COTTON ON EACH SIDE OF THE INNER BOX. WRAP THE PRODUCT IN THE THIRD STEP AND PUT IT IN A PE BAG, THEN PLACE A DESICCANT INSIDE. PUT IT INTO A CARDBOARD BOX AND SEAL THE PE BAG WITH ADHESIVE TAPE (WITH THE BOTTOM OF THE TRAY FACING DOWNWARDS). PLACE A PIECE OF PEARL COTTON ON TOP OF IT; (AS SHOWN IN FIGURE 3)
 5. THE CARDBOARD BOX IS SEALED WITH A "WORKER" AND A LABEL IS ATTACHED AT THE LABEL STICKING POINT; (AS SHOWN IN FIGURE 4)

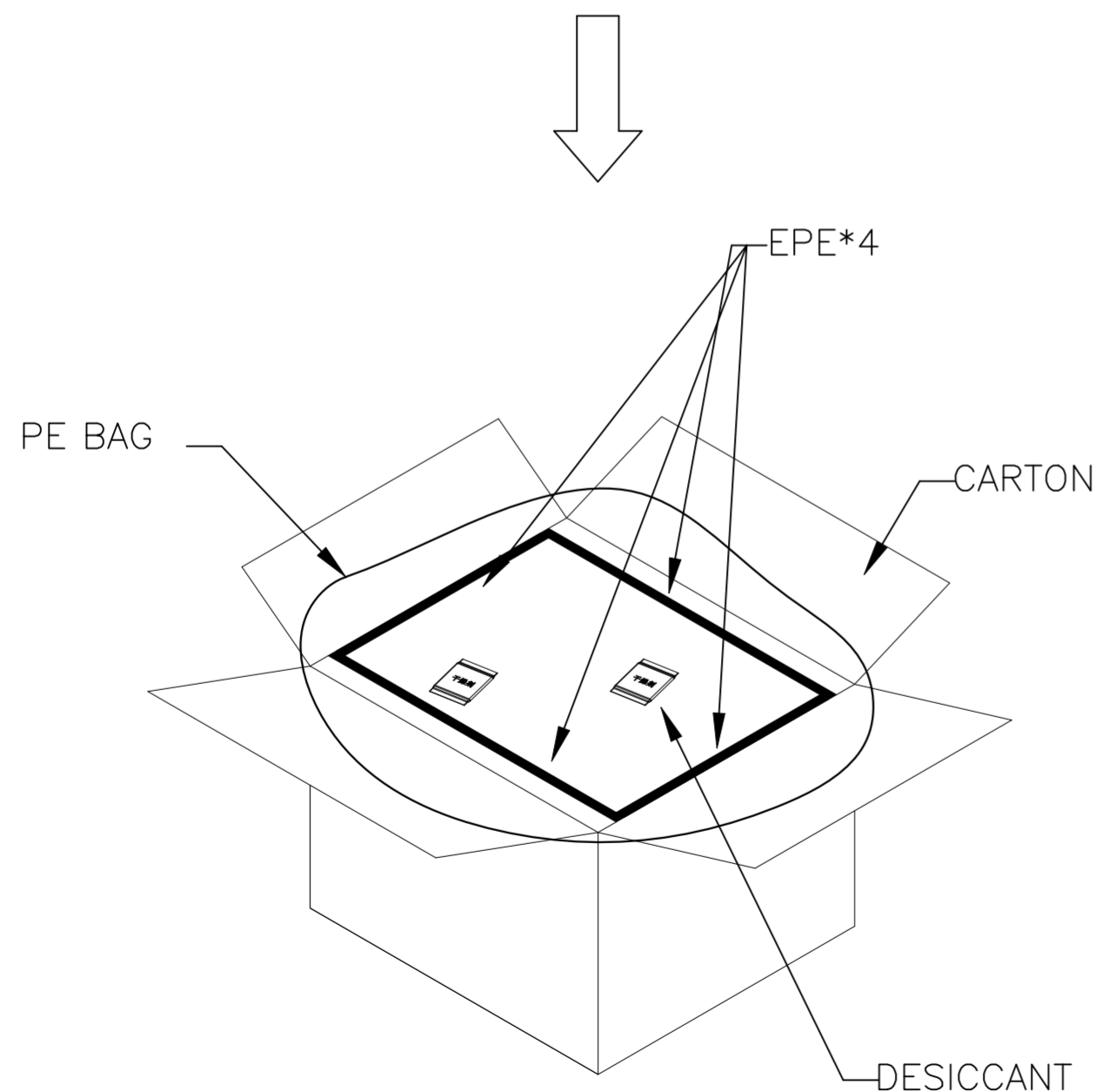

FIGURE 3

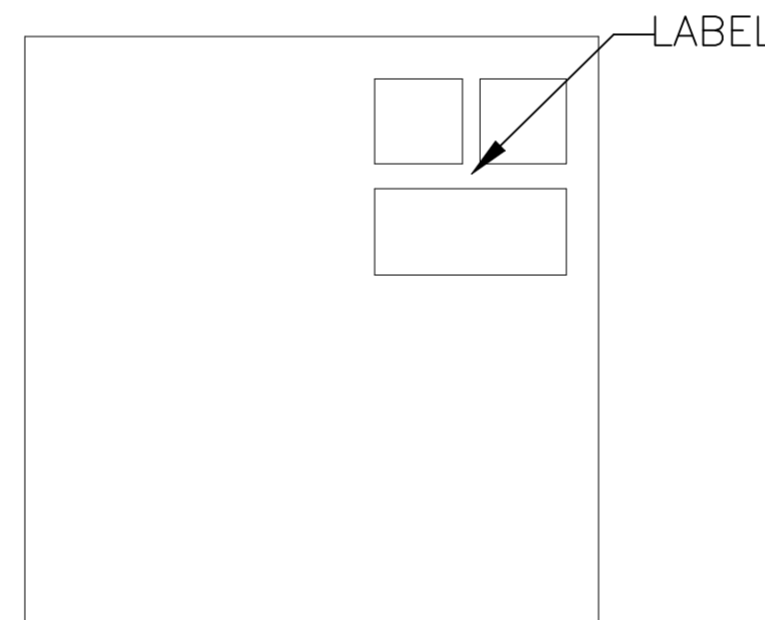

FIGURE 4

TRAY	250*230*9.5
Pcs/TRAY	30
Tray/CARTON	20
Pcs/CARTON	600
CARTON SIZE	300*280*220

220	25G	2499526-5
PIN No	SPEC	PART No

THIS DRAWING IS A CONTROLLED DOCUMENT.		DWN MANOJ K 13DEC2024	TE Connectivity	
DIMENSIONS: mm		CHK GOWTHAM CHITTY 13DEC2024		
TOLERANCES UNLESS OTHERWISE SPECIFIED:		APVD JAGRUTI MOHANTY 13DEC2024	NAME -	
0 PLC ± 0.50		PRODUCT SPEC	-	
1 PLC ± 0.20		108-161908	0.5 BTB Plug H4.45	
2 PLC ± 0.10		APPLICATION SPEC	-	
3 PLC ± 0.05		114-161404	SIZE	CAGE CODE
4 PLC ± 0.05		1	A2	00779
ANGLES ± 3'		WEIGHT	DRAWING NO	
MATERIAL SEE NOTE		CUSTOMER DRAWING	G-2499526	
FINISH SEE NOTE		SCALE	RESTRICTED TO	
		1:1	-	
		SHEET	REV	
		6 OF 10	A	

2499526

REVISIONS					
P	LTR	DESCRIPTION	DATE	DWN	APVD
-	-	SEE SHEET 1	-	-	-

1. 20 SPACES ARE RESERVED AT THE BEGINNING OF THE PACKAGING, AND THE CARRIER TAPE AND SELF-ADHESIVE FILM ARE CUT FLAT WITH THE CARRIER TAPE AND TAPED TOGETHER ADHERE TIGHTLY TO THE AXIS OF THE REEL, ALIGN THE PRODUCT DIRECTION, AND PLACE THEM IN SEQUENCE, AS SHOWN IN FIGURE 1

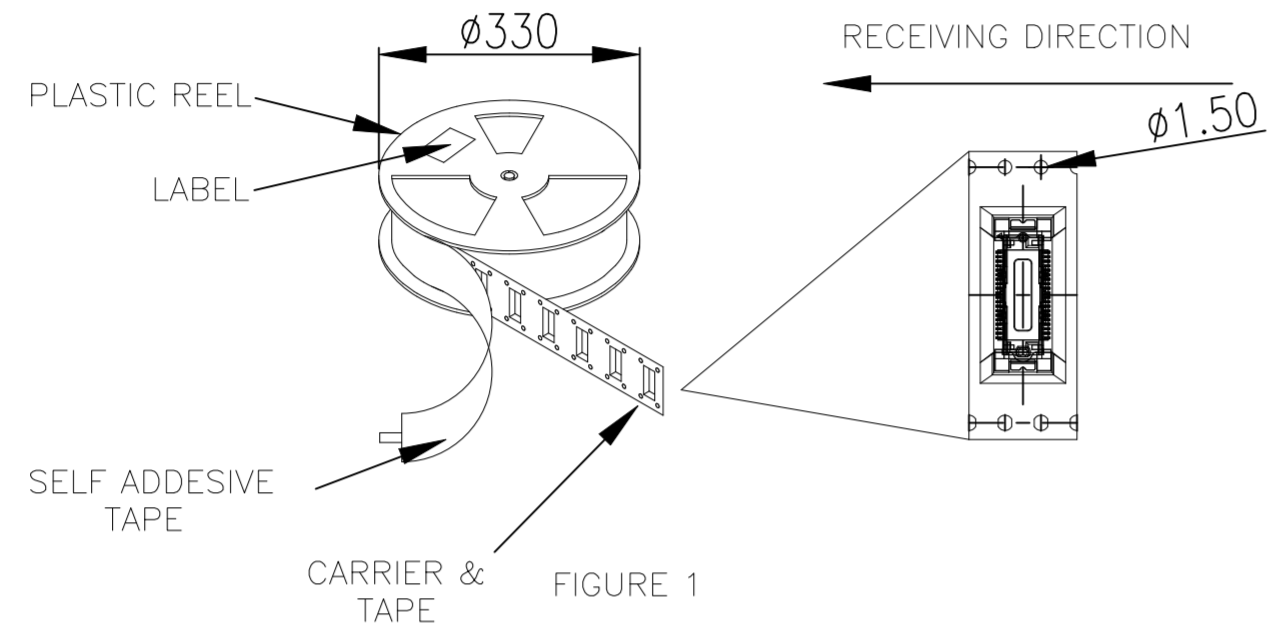

4.0 STICK THE LABEL ON THE TOP SIDE OF THE CARDBOARD BOX. IF THE CUSTOMER HAS SPECIAL REQUIREMENTS, FOLLOW THEM.

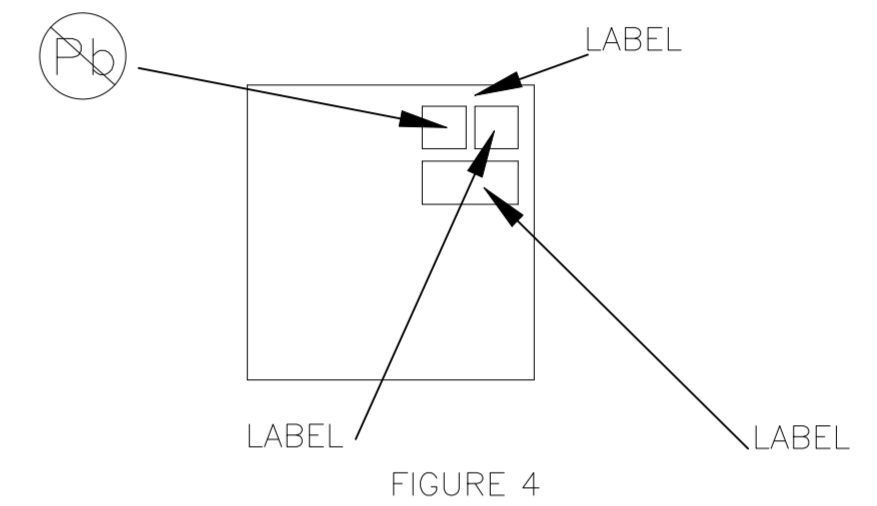

2. 20 SPACES SHOULD BE RESERVED FOR THE FINAL CARRIER TAPE OF THE PACKAGING, AND THE LAST END SHOULD BE A SELF-ADHESIVE FILM AND CARRIER TAPE CUT IT FLAT AND FIX IT WITH ADHESIVE TAPE. THE EDGE OF THE REEL ALSO NEEDS TO BE FIXED WITH ADHESIVE TAPE. STICK IT ON THE REEL PRODUCT PACKAGING LABEL (ATTACHED TO ONE SIDE OF THE SMALL HOLE ON THE REEL), INDICATING THE PART NUMBER, QUANTITY, AND MANUFACTURING DATE, AS SHOWN IN FIGURE 2 (IF THE CUSTOMER HAS SPECIAL REQUIREMENTS, FOLLOW THE CUSTOMER'S REQUIREMENTS).

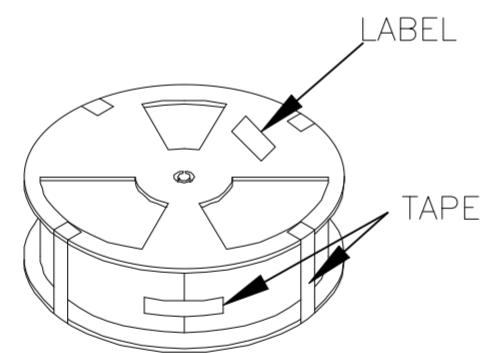

FIGURE 2

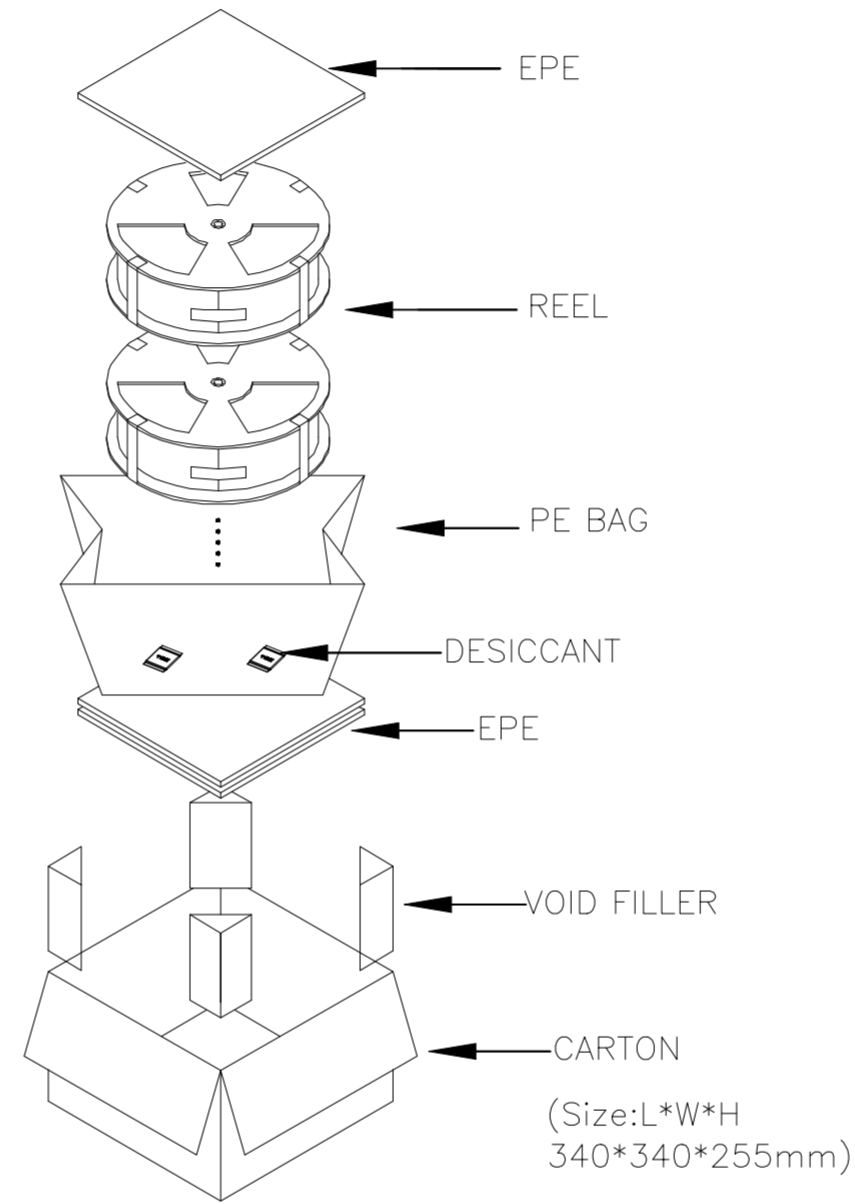
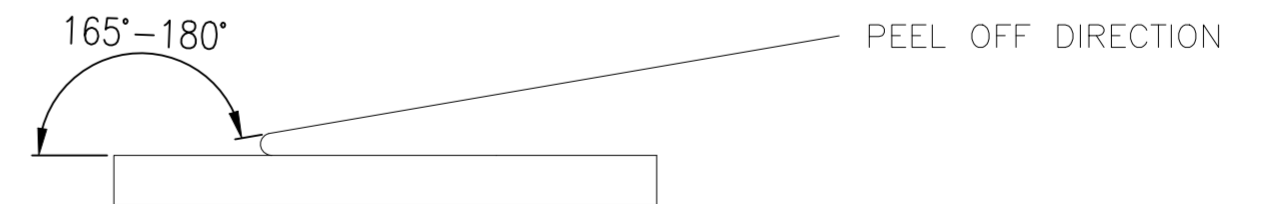

FIGURE 3

5.0 THE REQUIREMENT FOR UPPER TAPE PEELING FORCE IS:
 CARRIER TAPE WIDTH $\leq 56\text{MM}$:10-130GF
 CARRIER TAPE WIDTH $\geq 72\text{MM}$:10-150GF



3
 a). PACKAGING AS SHOWN IN THE DIAGRAM: THE REEL IS PACKED IN A WATERPROOF BAG, WITH 2PCS DESICCANT PLACED ON TOP AND BOTTOM, AND PADDING PLACED ON TOP AND BOTTOM 1PCS PEARL COTTON. THE TAPE SHALL NOT BE BROKEN, AND THE REEL THAT IS NOT FULLY ROLLED SHALL BE PACKED INTO ZERO BOXES AND SEALED WITH THE TAPE.
 b). PLEASE REFER TO THE NEXT PAGE FOR THE QUANTITY OF PACKAGING IN ONE ROLL.
 c). PLEASE REFER TO THE NEXT PAGE FOR THE QUANTITY OF PACKAGING IN ONE CARDBOARD BOX.

THIS DRAWING IS A CONTROLLED DOCUMENT.		DWN MANOJ K 13DEC2024	TE Connectivity	
DIMENSIONS: mm		CHK GOWTHAM CHITTY 13DEC2024		
TOLERANCES UNLESS OTHERWISE SPECIFIED:		APVD JAGRUTI MOHANTY 13DEC2024	NAME -	
0 PLC ± 0.50		PRODUCT SPEC 108-161908	0.5 BTB Plug H4.45	
1 PLC ± 0.20		APPLICATION SPEC 114-161404	SIZE A2	CAGE CODE 00779
2 PLC ± 0.10		MATERIAL SEE NOTE	DRAWING NO C-2499526	RESTRICTED TO -
3 PLC ± 0.05		FINISH SEE NOTE	WEIGHT 1	SCALE 1:1
4 PLC \pm			CUSTOMER DRAWING	SHEET 7 OF 10
ANGLES $\pm 3'$				REV A

REVISIONS				
P	LTR	DESCRIPTION	DATE	APVD
-	-	SEE SHEET 1	-	-

NOTES:

1. THERE ARE EMPTY BOXES THAT MUST BE FILLED WITH CUSHIONING MATERIALS.
2. PACKAGING MATERIALS CAN BE FOUND ON THIS PAGE.
3. WATERPROOF BAGS NEED TO BE TAPED TIGHTLY AND SEALED.
4. FILL THE OUTER BOX WITH FINISHED PRODUCTS. MAXIMUM NUMBER OF STACKED BOXES: 5 BOXES.

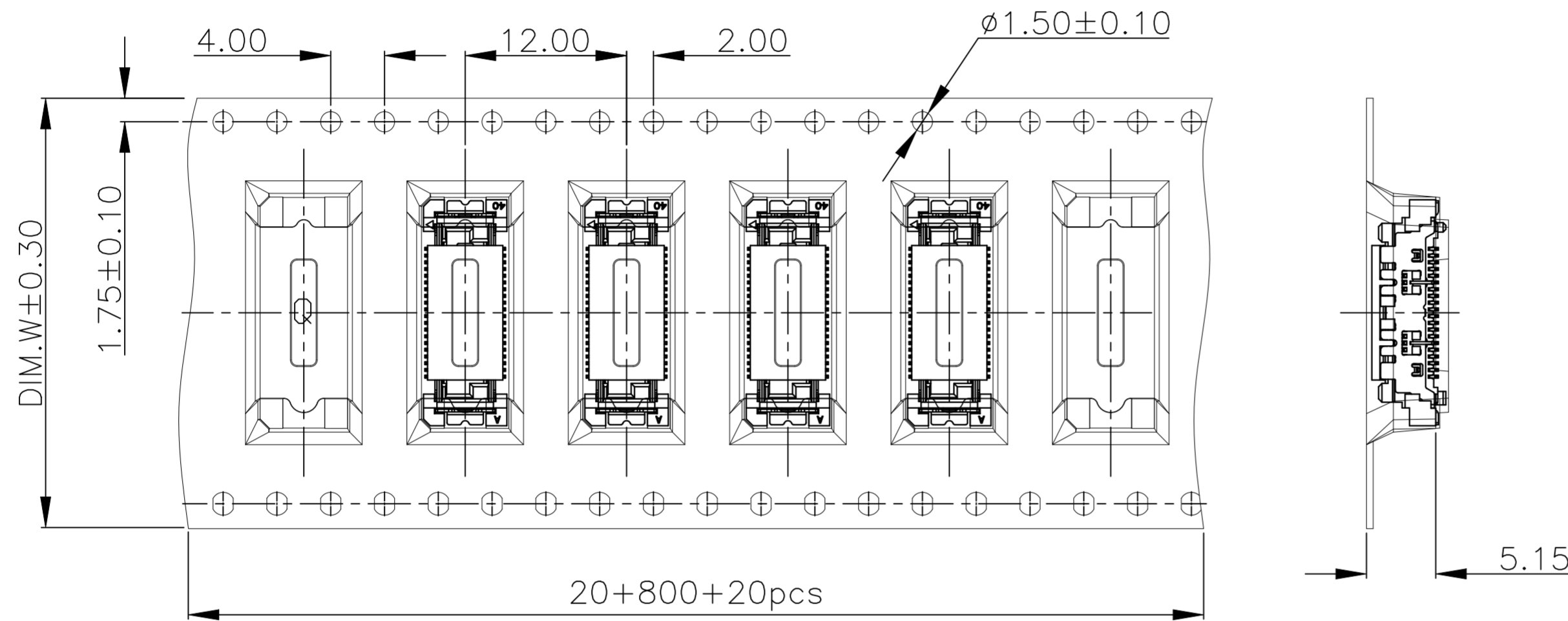

ITEM	Q'TY
CARTON	1 Pcs
PE BAG	1 Pcs
EPE	2 Pcs
DESICCANT	2 Pcs
CARRIER & TAPE	X/R(See table)
PLASTIC REEL	X/R(See table)
SELF ADDESIVE TAPE	A/R
VOID FILLER	4 Pcs

2499526

PIN NO	PRODUCT PN	PACKING CAPACITY			
		DIM.W	Pcs/REEL	REELS/CARTON	Pcs/CARTON
160	2499526-4	72mm	800	3R	2400
120	2499526-3	56mm	800	4R	3200
80	2499526-2	44mm	800	5R	4000
40	2499526-1	32mm	800	6R	4800

THIS DRAWING IS A CONTROLLED DOCUMENT.

DWN MANOJ K 13DEC2024	TE Connectivity NAME 0.5 BTB Plug H4.45 SIZE CAGE CODE DRAWING NO RESTRICTED TO A2 00779 C-2499526 SCALE SHEET REV 1:1 8 of 10 A
CHK GOWTHAM CHITTY 13DEC2024	
APVD JAGRUTI MOHANTY 13DEC2024	
PRODUCT SPEC 108-161908	
APPLICATION SPEC 114-161404	WEIGHT 1
MATERIAL SEE NOTE	FINISH SEE NOTE
CUSTOMER DRAWING	

REVISIONS					
P	LTR	DESCRIPTION	DATE	DWN	APVD
-	-	SEE SHEET 1	-	-	-

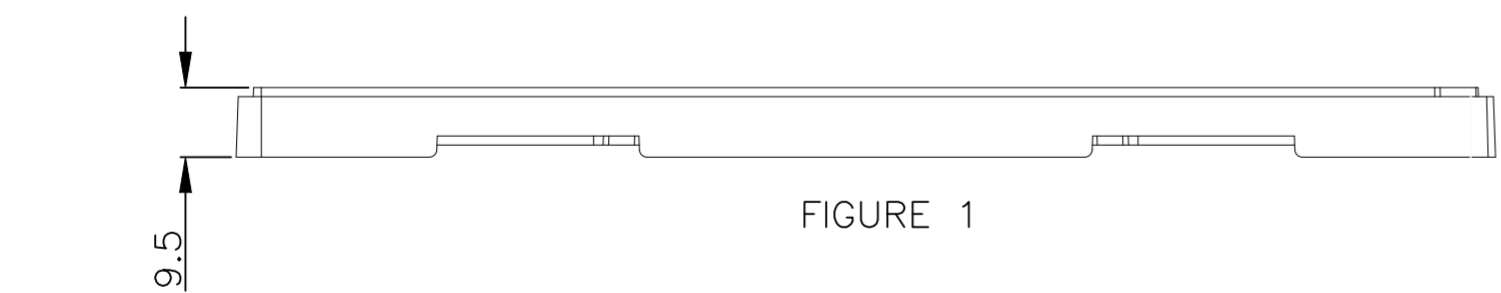
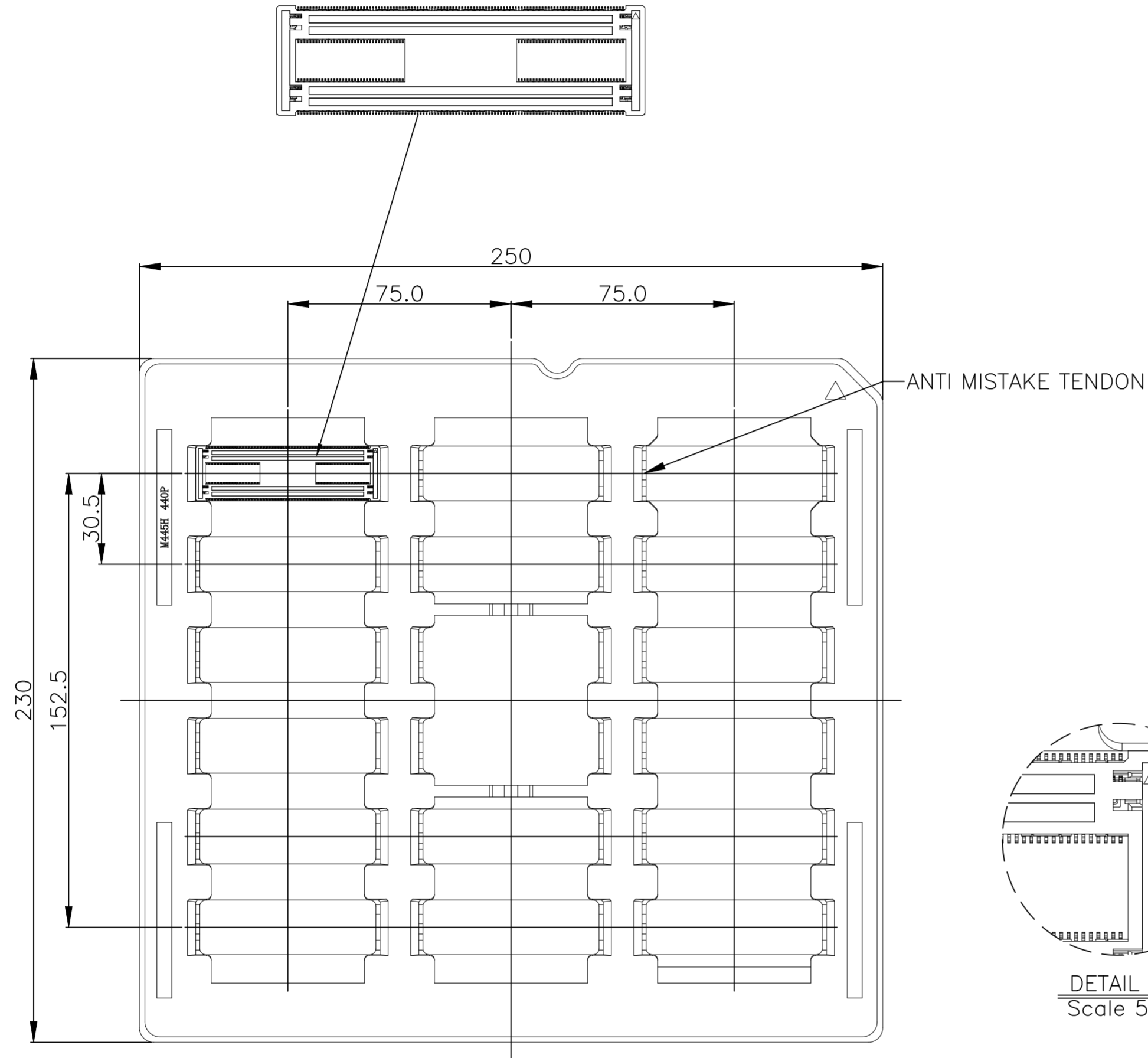
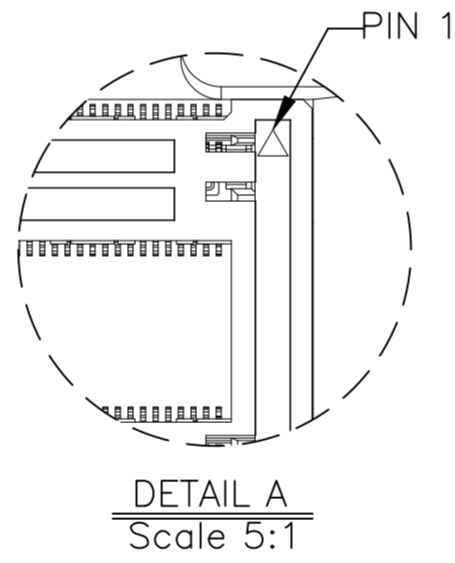

FIGURE 1



DETAIL A
Scale 5:1

NOTES:

- CORRECTLY PLACED, THE TRIANGLE SYMBOL OF THE TRAY DISK IS PLACED IN THE UPPER LEFT CORNER: THE TRIANGLE SYMBOL ON THE PRODUCT IS PIN 1, WHICH CORRESPONDS TO THE TRIANGLE IN THE UPPER LEFT CORNER OF THE TRAY DISK IN THE SAME DIRECTION, AND THE ANTI MISOPERATION PORT IS IN THE SAME DIRECTION AS THE TRAY ANTI MISOPERATION PORT.
- THE ENTIRE TRAY IS FILLED WITH PRODUCTS, AND THE TRAY IS STACKED IN THE SAME DIRECTION. 20 TRAYS OF PRODUCTS PLUS 1 EMPTY TRAY FORM 1 BUNDLE, WITH LABELS ATTACHED TO THE EMPTY TRAYS. PE TAPE IS USED TO CROSS WRAP AT LEAST 2 TURNS (WIDTH 60MM) AS SHOWN IN FIGURE 2

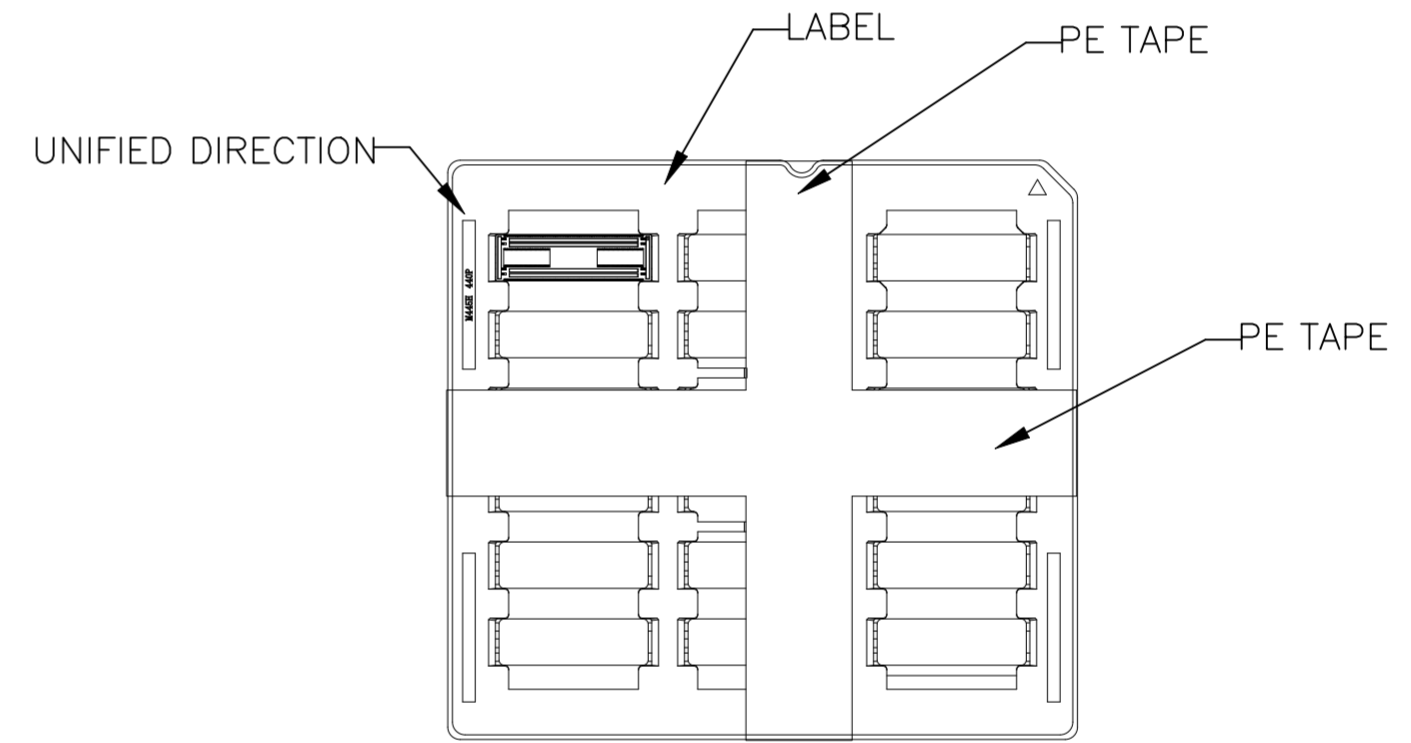

FIGURE 2

FOR PART:2499526-6

THIS DRAWING IS A CONTROLLED DOCUMENT.		DWN MANOJ K 13DEC2024	TE Connectivity													
		CHK GOWTHAM CHITTY 13DEC2024														
		APVD JAGRUTI MOHANTY 13DEC2024	NAME													
		PRODUCT SPEC 108-161908	-													
		APPLICATION SPEC 114-161404	0.5 BTB Plug H4.45													
DIMENSIONS: mm		TOLERANCES UNLESS OTHERWISE SPECIFIED:	SIZE A2	CAGE CODE 00779												
<table border="0"> <tr><td>0 PLC</td><td>± 0.50</td></tr> <tr><td>1 PLC</td><td>± 0.20</td></tr> <tr><td>2 PLC</td><td>± 0.10</td></tr> <tr><td>3 PLC</td><td>± 0.05</td></tr> <tr><td>4 PLC</td><td>± 0.05</td></tr> <tr><td>ANGLES</td><td>± 3'</td></tr> </table>		0 PLC	± 0.50	1 PLC	± 0.20	2 PLC	± 0.10	3 PLC	± 0.05	4 PLC	± 0.05	ANGLES	± 3'	WEIGHT 1	DRAWING NO C-2499526	RESTRICTED TO -
0 PLC	± 0.50															
1 PLC	± 0.20															
2 PLC	± 0.10															
3 PLC	± 0.05															
4 PLC	± 0.05															
ANGLES	± 3'															
MATERIAL SEE NOTE		FINISH SEE NOTE	CUSTOMER DRAWING													
		SCALE 1:1	SHEET 9 OF 10	REV A												

REVISIONS				
P	LTR	DESCRIPTION	DATE	APVD
-	-	SEE SHEET 1	-	-

NOTES:

1. WATERPROOF BAGS NEED TO BE TAPED TIGHTLY AND SEALED. IF THERE ARE ANY UNFILLED BOXES, THEY MUST BE FILLED WITH CUSHIONING MATERIALS
2. FILL THE OUTER BOX WITH FINISHED PRODUCTS, MAXIMUM NUMBER OF STACKED BOXES: 5 BOXES.
3. WRAP THE WHOLE BUNDLE OF PRODUCTS FIRMLY WITH PE FILM.
4. PLACE ONE PEARL AT THE BOTTOM OF THE BOX, AND ONE PEARL COTTON ON EACH SIDE OF THE INNER BOX.
WRAP THE PRODUCT IN THE THIRD STEP AND PUT IT IN A PE BAG, THEN PLACE A DESICCANT INSIDE. PUT IT INTO A CARDBOARD BOX AND SEAL THE PE BAG WITH ADHESIVE TAPE (WITH THE BOTTOM OF THE TRAY FACING DOWNWARDS). PLACE A PIECE OF PEARL COTTON ON TOP OF IT; (AS SHOWN IN FIGURE 3)
5. THE CARDBOARD BOX IS SEALED WITH A "WORKER" AND A LABEL IS ATTACHED AT THE LABEL STICKING POINT; (AS SHOWN IN FIGURE 4)

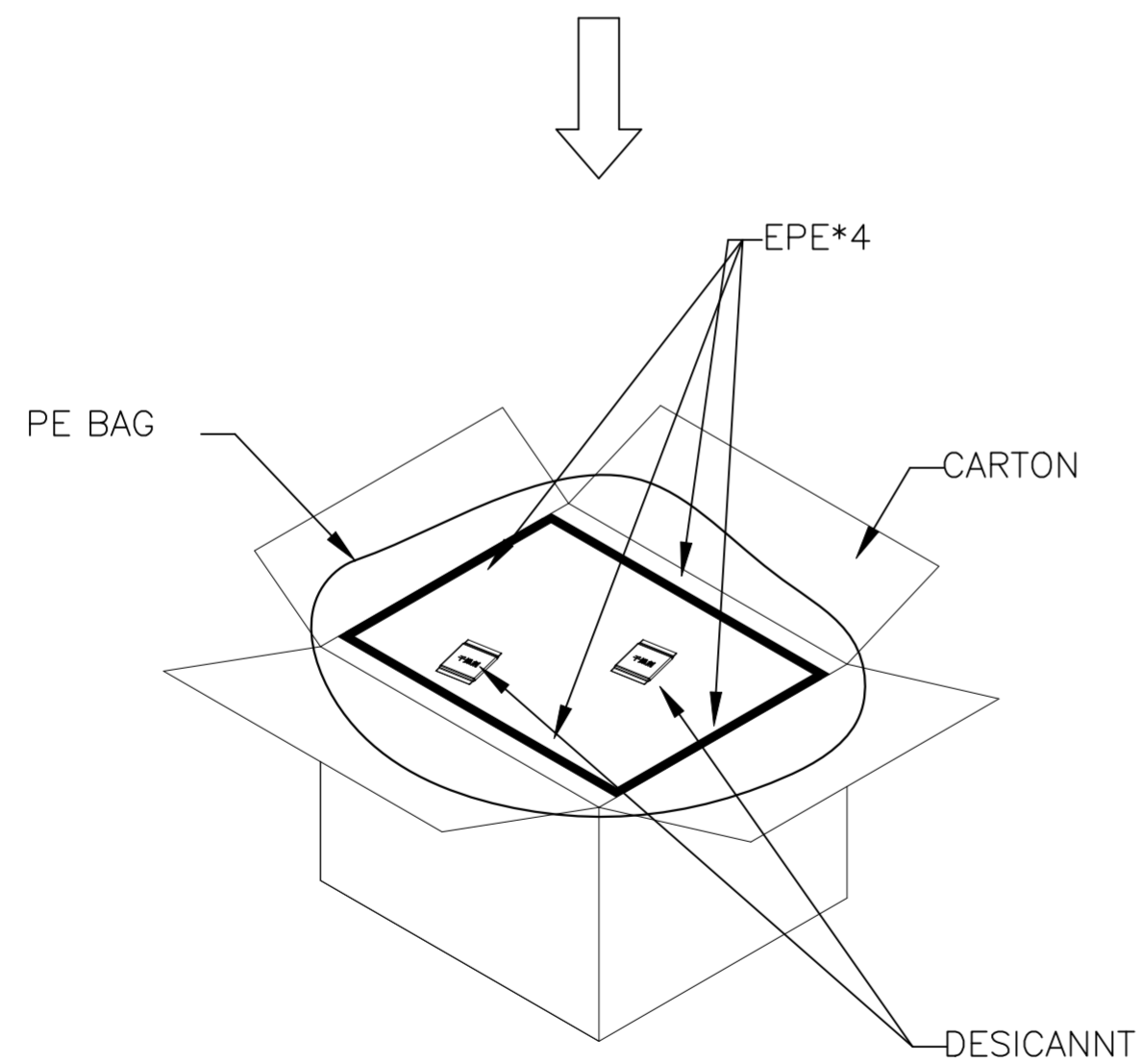
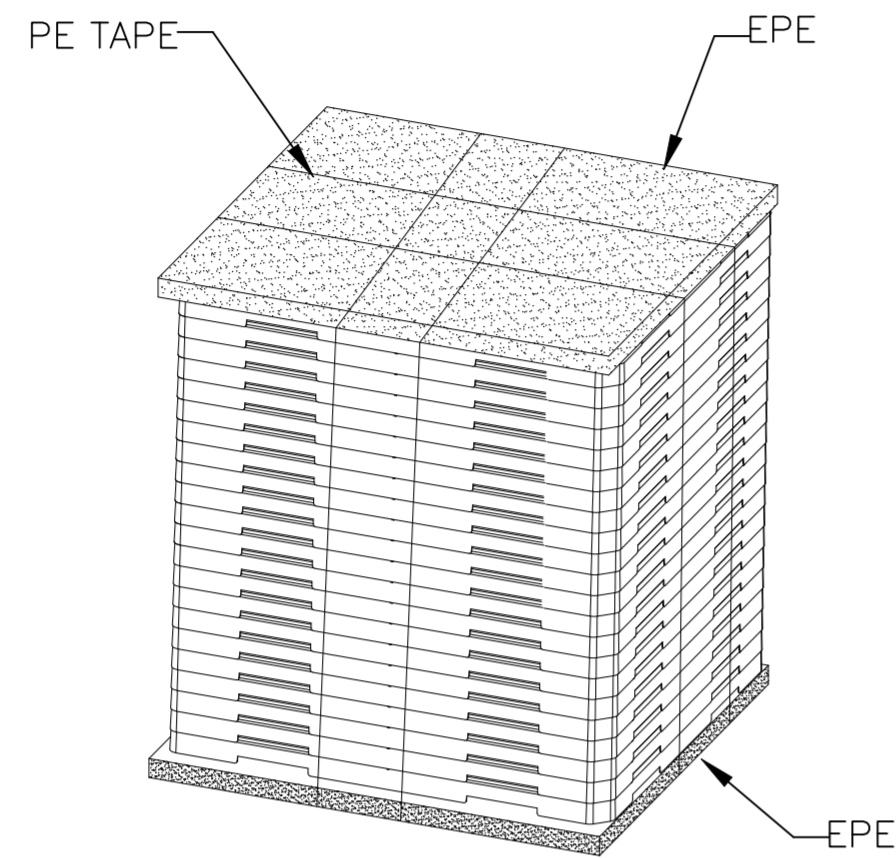

FIGURE 3

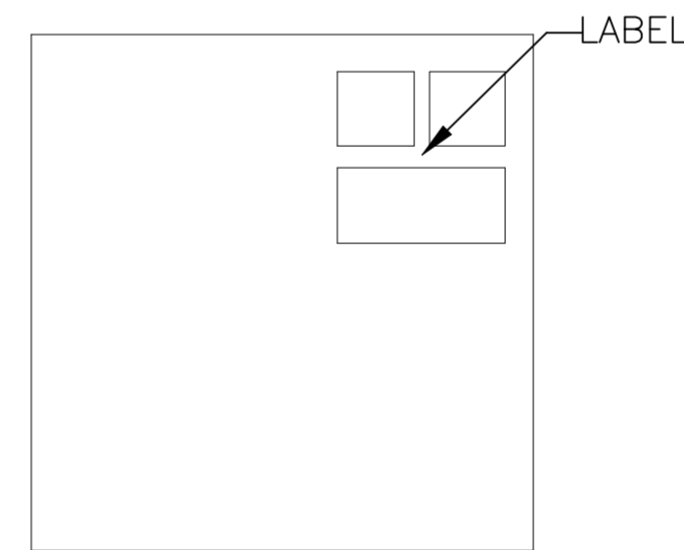

FIGURE 4

25G	2499526-6	TRAY	250*230*9.5
		Pcs/TRAY	18
		Tray/CARTON	20
		Pcs/CARTON	360
SPEC	PART NO	CARTON SIZE	300*280*220

THIS DRAWING IS A CONTROLLED DOCUMENT.		DWN	MANOJ K	13DEC2024	 TE Connectivity			
DIMENSIONS:		CHK	GOWTHAM CHITTY	13DEC2024				
TOLERANCES UNLESS OTHERWISE SPECIFIED:		APVD	JAGRUTI MOHANTY	13DEC2024				
mm		NAME						
0 PLC ± 0.50 1 PLC ± 0.20 2 PLC ± 0.10 3 PLC ± 0.05 4 PLC ± ± 3°		PRODUCT SPEC			0.5 BTB Plug H4.45			
		APPLICATION SPEC						
MATERIAL		WEIGHT			SIZE	CAGE CODE	DRAWING NO	RESTRICTED TO
SEE NOTE		1			A2	00779	2499526	-
		CUSTOMER DRAWING			SCALE	1:1	SHEET	10 OF 10
							REV	A