

THIS DRAWING IS UNPUBLISHED. RELEASED FOR PUBLICATION - , -
 © COPYRIGHT - By - ALL RIGHTS RESERVED.

| LOC | DIST | REVISIONS | | | |
|-----|------|-------------|---------------------------|---------|--------|
| P | LTR | DESCRIPTION | DATE | DWN | APVD |
| G | 14 | F1 | REVISED PER ECO-11-004820 | 11MAR11 | RK HMR |

| | | |
|--------------------------------|--------------------------------|--------------------------------|
| AMP WIRE RANGE | Listed | LR7189 Certified |
| 22-16 AWG SOLID OR STRANDED | 22-16 AWG SOLID OR STRANDED | 22-16 AWG SOLID OR STRANDED |

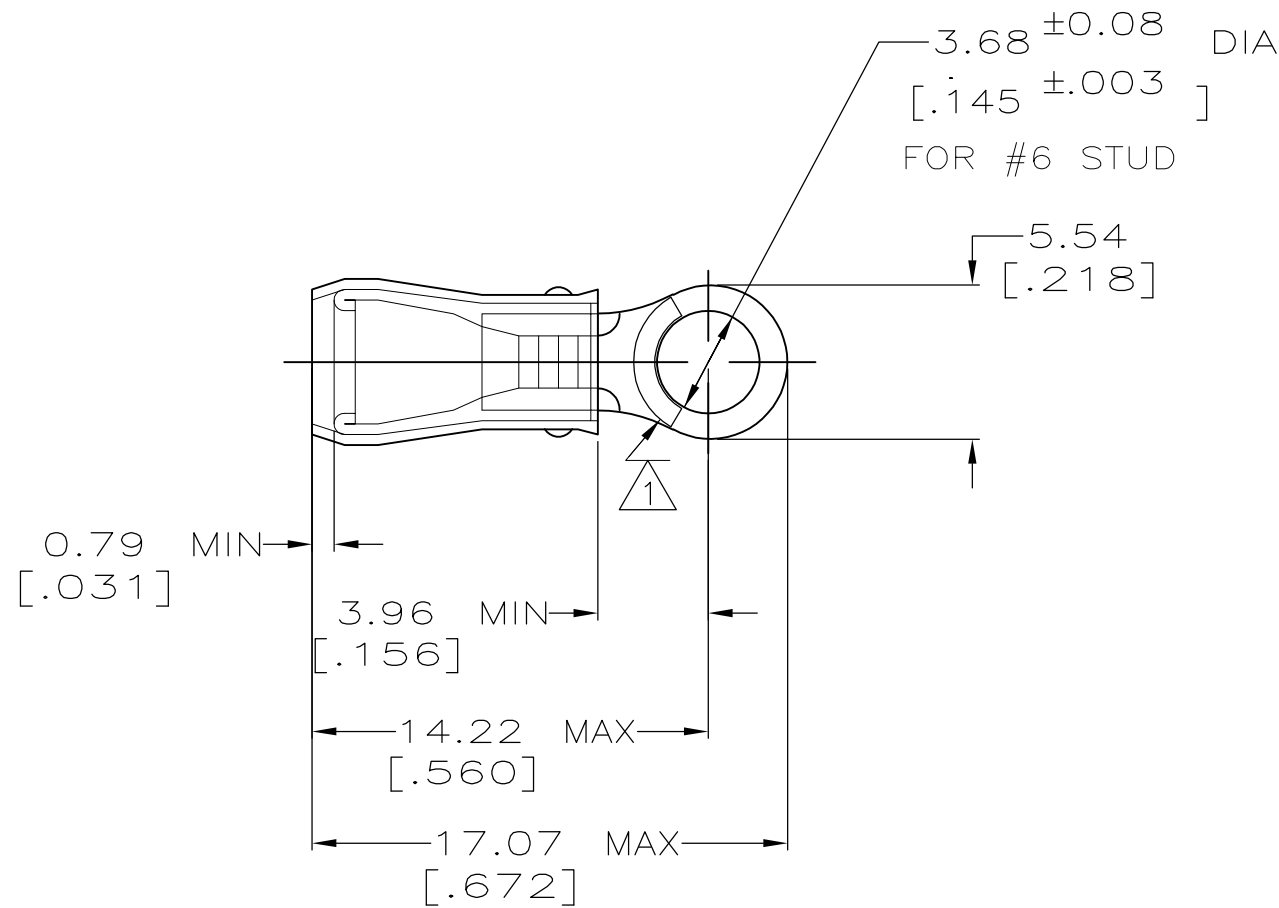

- 1 STAMP AMP 22-18* APPROX AS SHOWN
22-16 TERMINALS ARE STAMPED 22-18 IN
ACCORDANCE WITH MILITARY SPEC MIL-T-7928
COMMERCIAL WIRE RANGE IS 22-16
- 2 WIRE INSULATION DIA: .105 - .140
- 3 TONGUE MATERIAL THK: 0.79 ±0.05 [.031 ±0.002]

| MILITARY P/N AND CLASS | QUANTITY | PACKAGE TYPE | PART NO |
|-----------------------------|----------|-----------------|-----------|
| - | 100 | LOOSE PIECE BOX | 8-36150-1 |
| MS 25036-101 CLASS 2 | 5000 | ON TAPE, REEL | 2-36150-1 |
| MS 25036-101 CLASS 1 & 2 | - | LOOSE PIECE | 36150 |

| | | |
|---|--|--|
| AMP INCORPORATED CUSTOMER SERVICE SYSTEMS | | MAX RECOMMENDED OPERATING TEMPERATURE: 105° C MAX |
| FOR ADDITIONAL PRODUCT INFORMATION OR COPIES OF DRAWINGS AND TECHNICAL DOCUMENTS | PRODUCT INFORMATION CENTER 1-800-522-6752 | VOLTAGE RATING: 300 V MAX |
| FOR APPLICATION TOOLING INFORMATION | TOOLING ASSISTANCE CENTER 1-800-722-1111 | WIRE CROSS SECTIONAL AREA RANGE: 0.26-1.65mm ² [509-3,260] CIR MILS SOLID OR STRANDED |
| FOR ORDER ENTRY | 1-800-526-5142 | THIS DRAWING IS A CONTROLLED DOCUMENT FOR AMP INCORPORATED. IT IS SUBJECT TO CHANGE AND THE CONTROLLING ENGINEERING ORGANIZATION SHOULD BE CONTACTED FOR THE LATEST REVISION. |

| | | | | |
|--|--|-----------------------------------|--|-----------------------|
| THIS DRAWING IS A CONTROLLED DOCUMENT. | | DWN DK SCHRUM 02/11/93 | TE Connectivity | |
| DIMENSIONS: mm [INCHES] | | CHK RE HERSEY 4/28/93 | NAME TERMINAL, RING TONGUE, PIDG TM | |
| TOLERANCES UNLESS OTHERWISE SPECIFIED: 0 PLC ± - 1 PLC ± - 2 PLC ± 0.20 [.008] 3 PLC ± - 4 PLC ± - ANGLES ± - | | APVD ML ELLIS 4/28/93 | WIRE SIZE, 22-16 AWG | |
| MATERIAL COPPER ASTM B-152 SLEEVE RED NYLON | | PRODUCT SPEC UL 486A | SIZE A3 | RESTRICTED TO - |
| FINISH TIN PLATE PER MIL-T-10727 | | APPLICATION SPEC NOT AVAILABLE | CAGE CODE 00779 | DRAWING NO C-36150 |
| CUSTOMER DRAWING | | | SCALE 4:1 | SHEET 1 OF 1 |
| | | | REV F1 | |