

THIS DRAWING IS UNPUBLISHED. RELEASED FOR PUBLICATION  
 © COPYRIGHT - By - ALL RIGHTS RESERVED.

LOC	DIST	REVISIONS			
P	LTR	DESCRIPTION	DATE	DWN	APVD
G	14	D2	REVISED PER ECO-11-013258	28JUN11	HMR DR

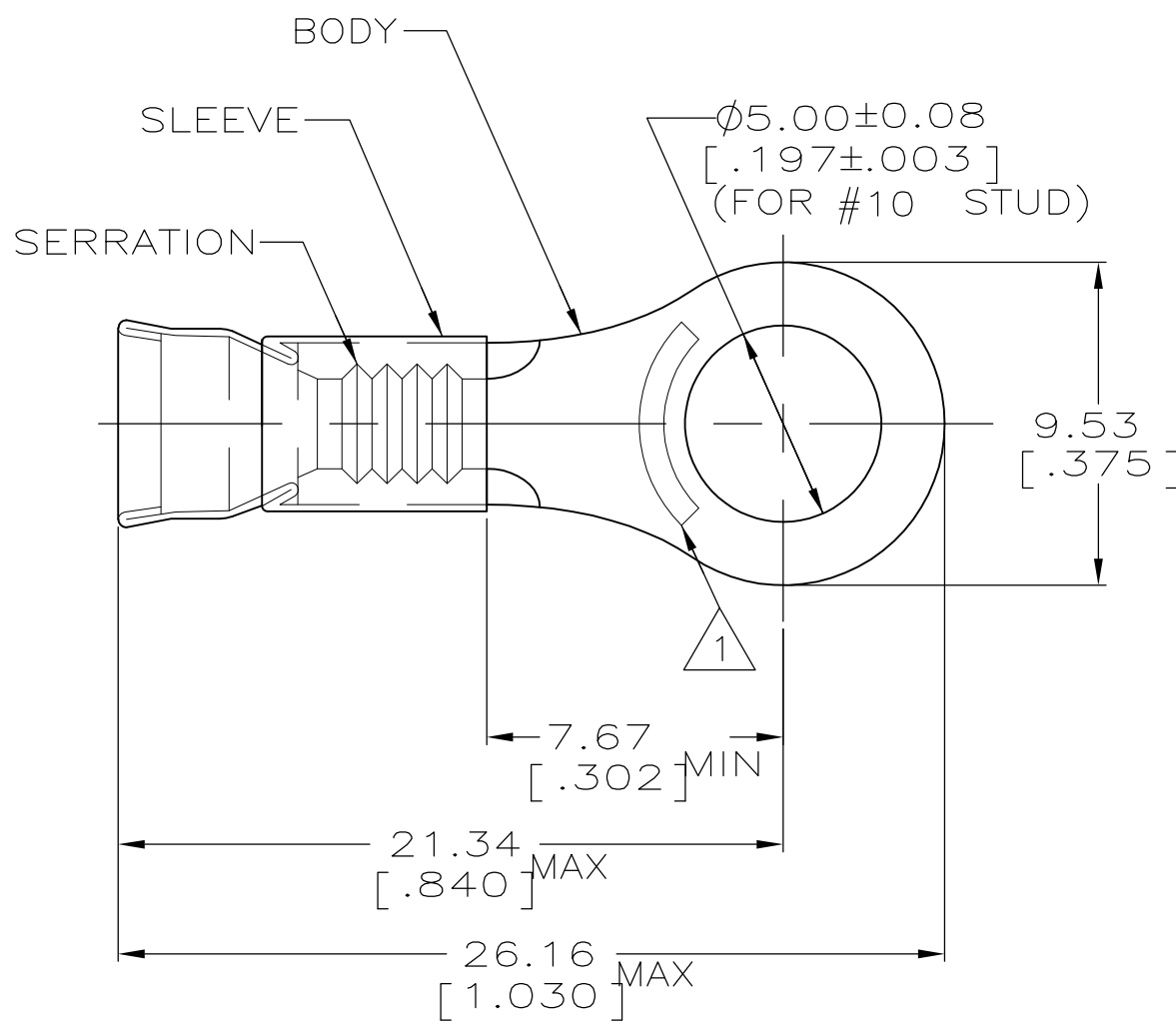

- 1 STAMP AMP 12-10\* APPROX AS SHOWN
- 2 WIRE INSUL DIA, 3.81-6.35 [.150-.250]
- 3 TONGUE MATL THK, 0.99±0.05 [.039±.002]

500	LOOSE PIECE	325154
QTY	PACKAGE TYPE	PART NO

**AMP INCORPORATED  
 CUSTOMER SERVICE SYSTEM**

FOR ADDITIONAL PRODUCT INFORMATION OR COPIES OF DRAWINGS AND TECHNICAL DOCUMENTS  
 PRODUCT INFORMATION CENTER  
 1-800-522-6752

FOR APPLICATION TOOLING INFORMATION  
 TOOLING ASSISTANCE CENTER  
 1-800-722-1111

FOR ORDER ENTRY  
 1-800-526-5142

MAX RECOMMENDED OPERATING TEMPERATURE:  
 343° C [650° F]

VOLTAGE RATING:  
 -

CIRCULAR MIL AREA:  
 2.62mm<sup>2</sup>-6.64mm<sup>2</sup> [5180-13100]

STRANDED WIRE

THIS DRAWING IS A CONTROLLED DOCUMENT.

DIMENSIONS: mm

TOLERANCES UNLESS OTHERWISE SPECIFIED:

0 PLC	± -
1 PLC	± -
2 PLC	± 0.20 [.008]
3 PLC	± -
4 PLC	± -
ANGLES	± -

MATERIAL  
 BODY: CU PER ASTM B152  
 SLEEVE: NI SIL PER ASTM B122

FINISH  
 BODY, NP, QQ-N-290

DWN L OLMEDA 10OCT94  
 CHK M ELLIS 10OCT94  
 APVD S BORTNER 10OCT94

PRODUCT SPEC  
 -

APPLICATION SPEC  
 -

WEIGHT  
 -

CUSTOMER DRAWING

**STE** TE Connectivity

NAME  
 TERMINAL, RING TONGUE,  
 STRATOTHERM™,  
 DIAMOND GRIP™ WIRE SIZE, 12-10 AWG

SIZE	CAGE CODE	DRAWING NO	RESTRICTED TO
A3	00779	C-325154	-

SCALE 4:1 SHEET 1 OF 1 REV D2