



Emergency-Stop Relay

Basic Unit

According to EN 60204 - 1 and EN 954 - 1
Feedback Circuit for Monitoring External Contactors
Single or Dual Channel E-Stop Possible
Rated Voltage in the E-Stop Control Circuit: 24 V DC

SNO 1005	EN 60204-1	For Stop Category	0
	EN 954-1	Safety Category	4

SNO 1005

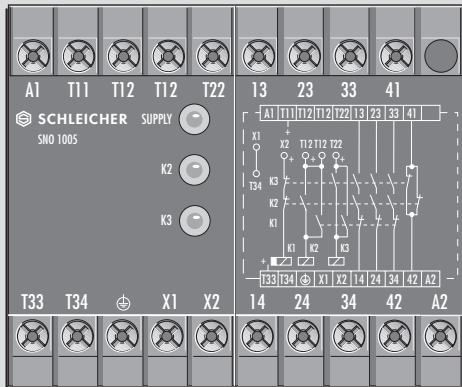

For Example

- ▶ Protection of persons and machines
- ▶ Monitoring of sliding safety screens
- ▶ Protective measures on industrial robots
- ▶ In conjunction with programmable logic control

Function

After the supply voltage is applied to terminals A1/A2, and if the E-stop switch is not activated, the relay K1 is energized by the RESET switch. The contacts of relay K1 trigger the relays K2 and K3. The latter become self-locking through their own contacts. At the same time, the relay contacts of K2 and K3 de-energize relay K1. After a drop-out time delay t_{R1} this relay goes over into its off-position. After this switch-on phase, the three enabling current paths, which are intended for the output, are activated (terminals connection for: enabling current paths = 13/14, 23/24, 33/34 control contact = 41/42). It can be used, e.g., for indicator purposes. Three LEDs provide a display, and these LEDs are associated with the safety channels and the power supply. If the E-Stop switch is activated, the current leads for the K2 and K3 relays are interrupted. The enabling current paths 13/14, 23/24 and 33/34 at the output are opened and the NC 41/42 is closed. The shunt T34/X1 is used as a support point to simplify the wiring.

Function Diagram

FD 0108 W3

SNO 1005

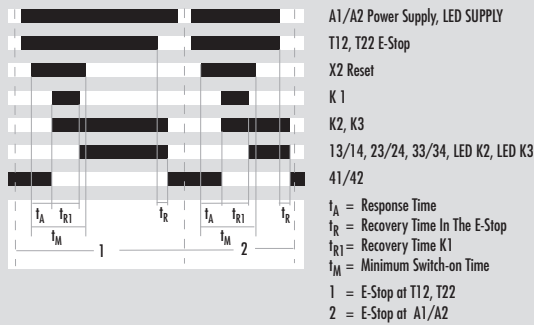

Notes

- ▶ The emergency-stop control circuit can be monitored for a ground fault through the PE device connection for AC devices.
- ▶ The PE connection is omitted for DC devices.
- ▶ To multiply the enabling current paths, expansion units, or external contactive elements with positively driven contacts must be used.

Connection Diagram

KS 0316/3

SNO 1005

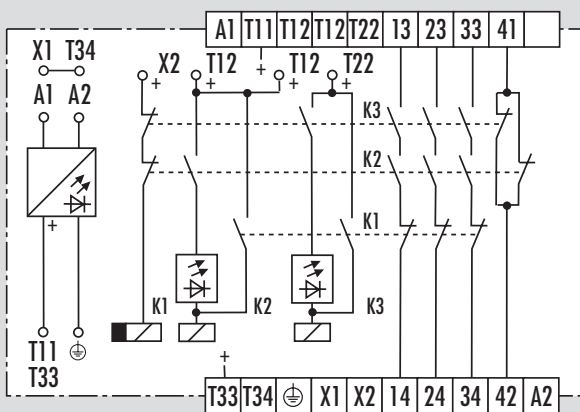

Dimension Diagram

for DIN-Rail acc. to EN 50022

S 4-6

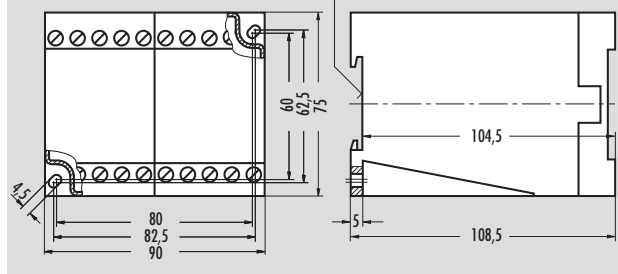

Approvals



Order Example

SNO 1005 230 V AC
 Type Rated Voltage



Application Example

A 1010

Dual Channel E-Stop Circuit

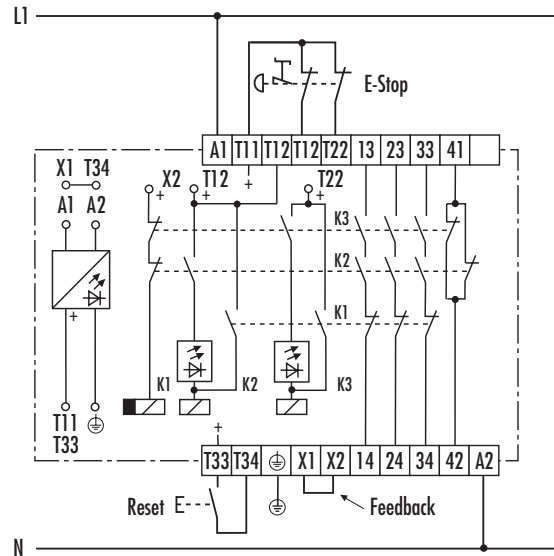

The dual channel E-Stop circuit switches off even if one of the two contacts of the E-Stop button does not open. If a fault occurs (e.g. the E-Stop contact connected to T22 does not open), the safety circuit is activated by the second (redundant) contact T12. The enabling current paths 13/14, 23/24 and 33/34 open, the auxiliary contact 41/42 closes. The remaining opened contact of K3 in the current path of K1 prevents the restart through the RESET switch. The feedback circuit X1/X2 is used to multiply the enabling current paths through external contactors.

Application Example

A 1080

Dual Channel Sliding Safety Gate Monitoring

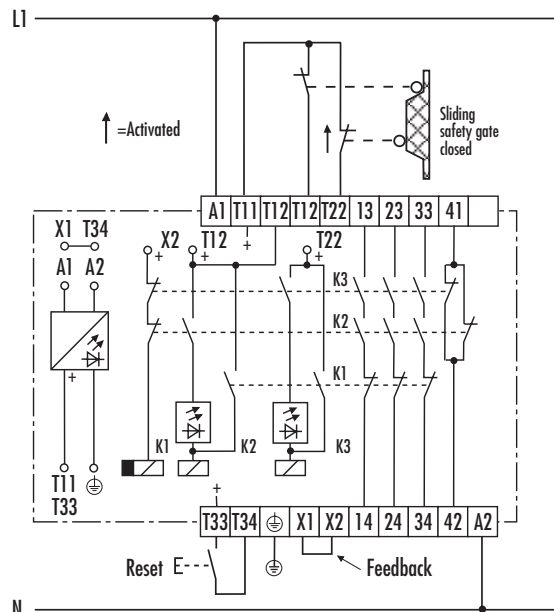

The position of the safety sliding gate is monitored through channel 1 (T12) and channel 2 (T22). The SNO 1005 is activated through the RESET switch. If the sliding safety gate opens, the E-Stop Safety Relay returns to its off-position and the enabling current paths 13/14, 23/24, 33/34 open, the auxiliary contact 41/42 closes. If the safety gate is closed again the E-Stop Safety Relay can be activated again through the RESET switch.

Application Example

A 1009

Dual Channel E-Stop Circuit

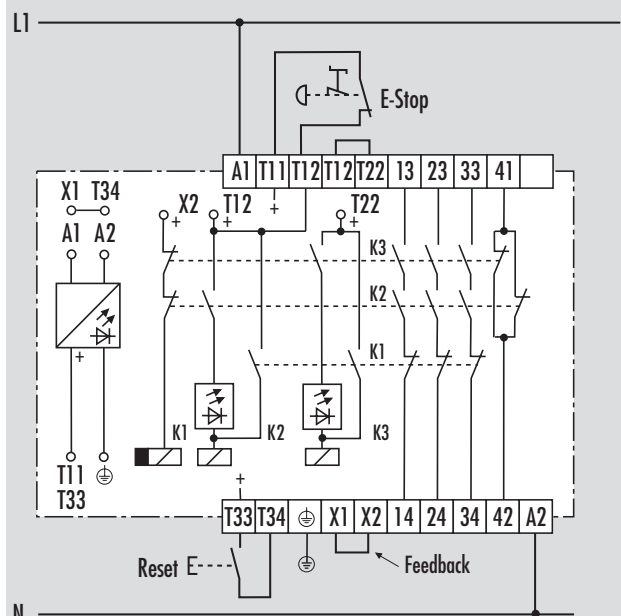

The single channel fulfills the requirements of EN 60204-1. However, the circuit of the E-Stop is not redundant. Ground faults in the circuit for the E-Stop contact are detected.

Application Example

A 1011

External Contact Wiring Expansion

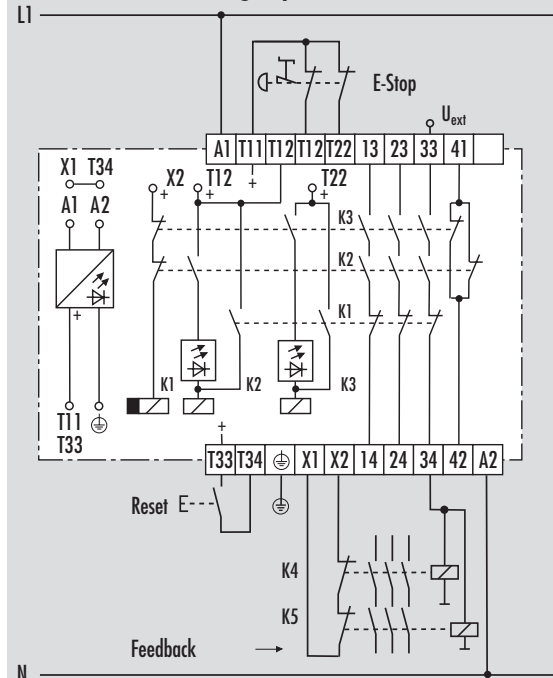

If the number of enabled current paths is not sufficient, two external contactors can be used for expansion. The contactors must have positively driven contacts. They are driven through one of the enabling current paths (33/34) of the SNO 1005. The function of the external contactors is monitored by their own NC contacts function connected in series with the feedback (terminals X1, X2).



TECHNICAL DATA

FUNCTION According to EN 60204-1
Function Display
Function Diagram

POWER SUPPLY DATA

Rated Voltage U_N	V AC
Rated Voltage U_N	V DC
Rated Consumption at 50 Hz and U_N (AC)	VA
Rated Consumption at 50 Hz and U_N (AC)	W
Rated Consumption at U_N (DC)	W
Residual Ripple	V _{ss}
Rated Frequency	Hz
Operating Voltage Range	

CONTROL CIRCUIT only for supplying the control inputs
Control output T11/T33 with respect to PE/A2 (AC-/DC-Unit):
Line Resistance (Control Inputs) Ω
Rated Output Voltage V DC
No-Load Voltage (AC- Unit) V DC
Rated Current mA
Rated Short-Circuit Current $I_{K \text{ max.}}$ mA
Fuse

Response Time (PTC)	s
Recovery Time (PTC)	s

Control Inputs T12, T22, X2	
Rated Current Input K1	mA
Rated Current Per Input K2, K3	mA
Response Time t_A K1, K2, K3	ms
Release Time t_{R1} Start-up Cycle K1	ms
Release Time t_r for the E-Stop K2, K3	ms
Minimum Switch-ON Time t_M for K1	ms

OUTPUT CIRCUIT

Contact Equipment	
Contact Type	
Contact Material	
Switching Voltage U_n	V AC/DC
Maximum Rated Current I_n per Contact	A
Maximum Total Current for all Contacts	A
Application Category According to EN 60947-5-1:1991	
Short-Circuit Protection, Max. Fuse Element Class gG	A
Permissible Switching Frequency	Switching Cycle/h
Mechanical Lifetime	Switching Cycles

GENERAL DATA

Creepage and Clearance Distances Between Circuits According to DIN VDE 0110-1:04.97: Rated Withstand Voltage	kV
Over-Voltage Category	
Contamination Level	
Design Voltage	V AC
Test Voltage U_{eff} 50 Hz acc. to DIN VDE 0110-1, Table A.1	kV
Protection Class Housing/Terminals acc. to DIN VDE 0470 Sec. 1:11.92	
Radiated Noise	
Noise Immunity	

Ambient Temperature, Working Range	°C
Dimension Diagram	
Connection Diagram	
Weight	kg
Approvals	

GENERAL TECHNICAL SPECIFICATIONS

SNO 1005

Emergency - Stop Relay
3 LED's green
FD 0108 W3

	24	115	120	230
24				
	4,2	4,2	4,2	4,2
	4,0	4,0	4,0	4,0
2,4				
2,4				
50 to 60				
0,8 to 1,1 x U_N				

≤ 70
24
≤ 40
80
3000
AC: Short-Circuit Proof Transformer
DC: PTC-Resistance
3
2

100
40
25
70
5
60

3 N.O. Safety Contact
1 N.C. Control Contact
Forced Contact
Ag-Alloy; Gold-Plated
230/230
6
18
AC-15: U_e 230 V AC, I_e 4 A
DC-13: U_e 24 V DC, I_e 6 A
6
3600
10 x 10 ⁶

4
III
3 Outside, 2 Inside
300
2,21
IP 40/IP 20
EN 50081-1:03.93, -2:03.94
EN 50082-2:1995

- 25 to + 55
S 4-6
KS 0316/3
0,6 (AC-Unit), 0,5 (DC-Unit)
BG, CSA, SAG, UL

Page i.11