

- $V_{DS}$  240 V
- $I_D$  0.25 A
- $R_{DS(on)}$  8  $\Omega$
- $V_{GS(th)}$  0.6 ... 1.2 V
- N channel
- Enhancement mode
- Logic level

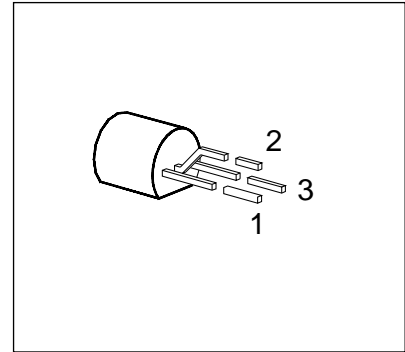
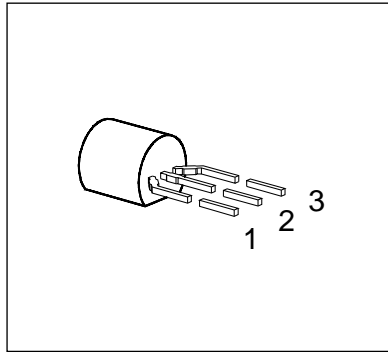

Type	Ordering Code	Tape and Reel Information	Pin Configuration			Marking	Package
			1	2	3		
BSS 88	Q62702-S454	bulk	G	D	S	BSS 88 marked SS88	TO-92
BSS 88	Q62702-S287	E6288: 1500 pcs/reel; 2 reels/carton; gate first					
BSS 88	Q62702-S303	E6296: 1500 pcs/reel; 2 reels/carton; source first					
BSS 88	Q62702-S576	E6325: 2000 pcs/carton; Ammopack					

### Maximum Ratings

Parameter	Symbol	Values	Unit
Drain-source voltage	$V_{DS}$	240	V
Drain-gate voltage, $R_{GS} = 20 \text{ k}\Omega$	$V_{DGR}$	240	
Gate-source voltage	$V_{GS}$	$\pm 14$	
Gate-source peak voltage, aperiodic	$V_{gs}$	$\pm 20$	
Continuous drain current, $T_A = 25 \text{ }^\circ\text{C}$	$I_D$	0.25	A
Pulsed drain current, $T_A = 25 \text{ }^\circ\text{C}$	$I_{D \text{ puls}}$	1.0	
Max. power dissipation, $T_A = 25 \text{ }^\circ\text{C}$	$P_{tot}$	1.0	W
Operating and storage temperature range	$T_j, T_{stg}$	- 55 ... + 150	$^\circ\text{C}$
Thermal resistance, chip-ambient (without heat sink)	$R_{thJA}$	$\leq 125$	K/W
DIN humidity category, DIN 40 040	-	E	-
IEC climatic category, DIN IEC 68-1	-	55/150/56	

**Electrical Characteristics**

at  $T_j = 25\text{ °C}$ , unless otherwise specified.

Parameter	Symbol	Values			Unit
		min.	typ.	max.	

**Static Characteristics**

Drain-source breakdown voltage $V_{GS} = 0, I_D = 0.25\text{ mA}$	$V_{(BR)DSS}$	240	–	–	V
Gate threshold voltage $V_{GS} = V_{DS}, I_D = 1\text{ mA}$	$V_{GS(th)}$	0.6	0.8	1.2	
Zero gate voltage drain current $V_{DS} = 240\text{ V}, V_{GS} = 0$ $T_j = 25\text{ °C}$ $T_j = 125\text{ °C}$	$I_{DSS}$	–	0.1	1.0	$\mu\text{A}$
$V_{DS} = 100\text{ V}, V_{GS} = 0$ $T_j = 25\text{ °C}$		–	–	100	
Gate-source leakage current $V_{GS} = 20\text{ V}, V_{DS} = 0$	$I_{GSS}$	–	10	100	nA
Drain-source on-resistance $V_{GS} = 4.5\text{ V}, I_D = 0.25\text{ A}$ $V_{GS} = 1.8\text{ V}, I_D = 14\text{ mA}$	$R_{DS(on)}$	–	4.0 6	8 15	$\Omega$

**Dynamic Characteristics**

Forward transconductance $V_{DS} \geq 2 \times I_D \times R_{DS(on)max}, I_D = 0.25\text{ A}$	$g_{fs}$	0.14	0.32	–	S
Input capacitance $V_{GS} = 0, V_{DS} = 25\text{ V}, f = 1\text{ MHz}$	$C_{iss}$	–	100	135	$\mu\text{F}$
Output capacitance $V_{GS} = 0, V_{DS} = 25\text{ V}, f = 1\text{ MHz}$	$C_{oss}$	–	15	25	
Reverse transfer capacitance $V_{GS} = 0, V_{DS} = 25\text{ V}, f = 1\text{ MHz}$	$C_{rss}$	–	8	12	
Turn-on time $t_{on}$ , ( $t_{on} = t_{d(on)} + t_r$ ) $V_{DD} = 30\text{ V}, V_{GS} = 10\text{ V}, R_{GS} = 50\text{ }\Omega, I_D = 0.28\text{ A}$	$t_{d(on)}$	–	5	8	ns
	$t_r$	–	10	15	
Turn-off time $t_{off}$ , ( $t_{off} = t_{d(off)} + t_f$ ) $V_{DD} = 30\text{ V}, V_{GS} = 10\text{ V}, R_{GS} = 50\text{ }\Omega, I_D = 0.28\text{ A}$	$t_{d(off)}$	–	40	55	
	$t_f$	–	30	40	

## Electrical Characteristics (cont'd)

at  $T_j = 25\text{ °C}$ , unless otherwise specified.

Parameter	Symbol	Values			Unit
		min.	typ.	max.	
Continuous reverse drain current $T_A = 25\text{ °C}$	$I_S$	–	–	0.25	A
Pulsed reverse drain current $T_A = 25\text{ °C}$	$I_{SM}$	–	–	1.0	A
Diode forward on-voltage $I_F = 0.5\text{ A}, V_{GS} = 0$	$V_{SD}$	–	0.85	1.3	V

## Reverse Diode

## Package Outline

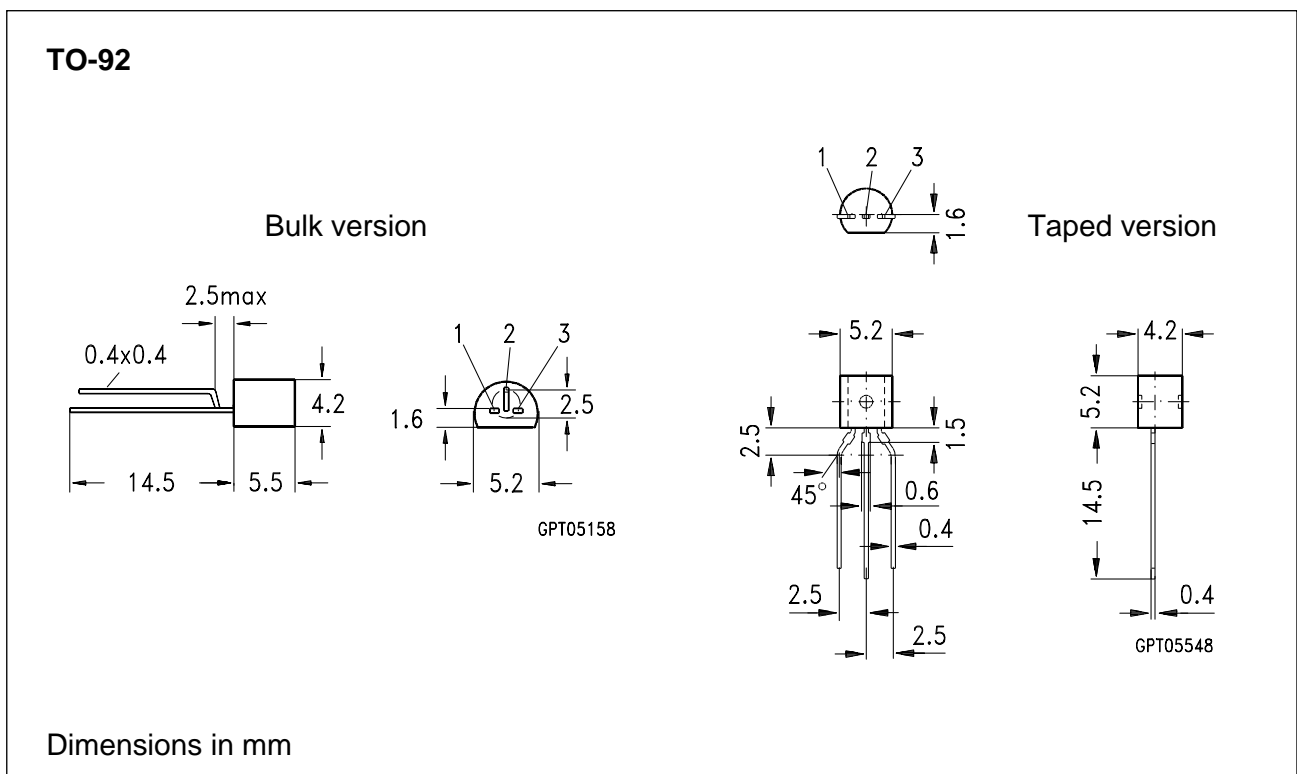

**Characteristics**

at  $T_j = 25^\circ\text{C}$ , unless otherwise specified.

**Total power dissipation  $P_{\text{tot}} = f(T_A)$**

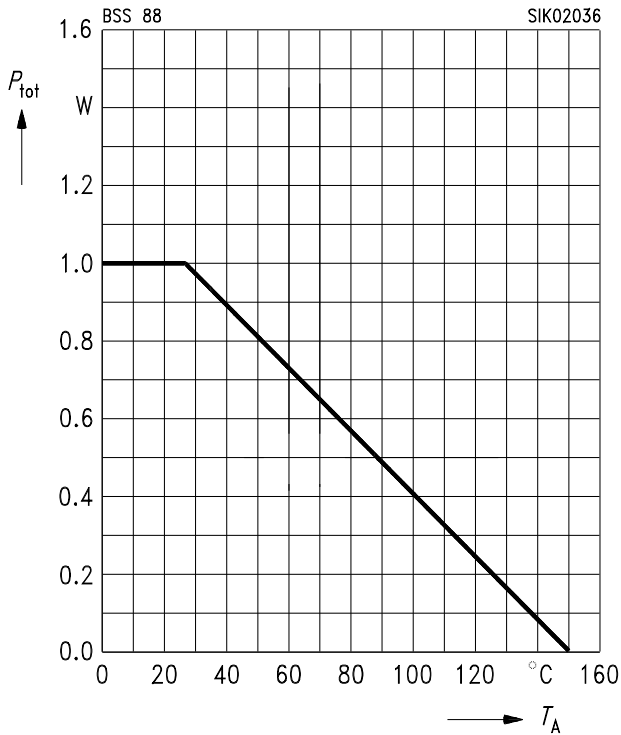

**Safe operating area  $I_D = f(V_{\text{DS}})$**

parameter:  $D = 0.01, T_C = 25^\circ\text{C}$

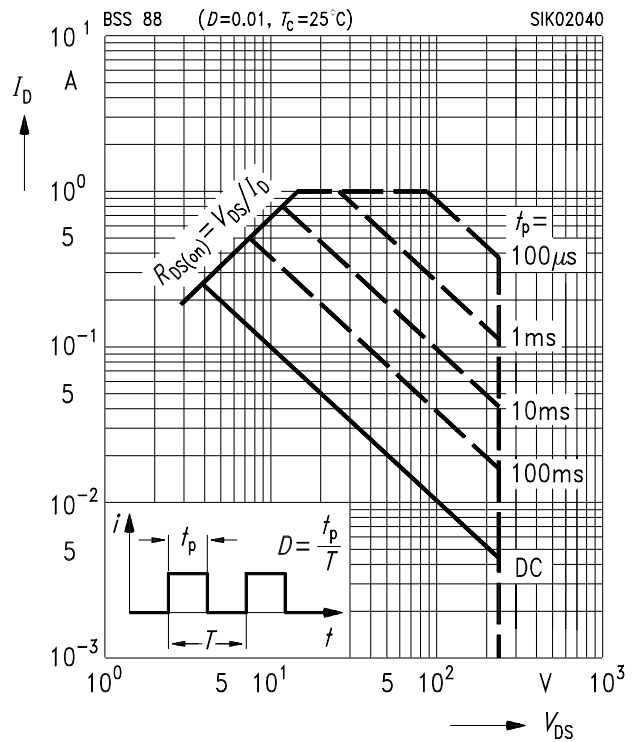

**Typ. output characteristics  $I_D = f(V_{\text{DS}})$**

parameter:  $t_p = 80 \mu\text{s}$

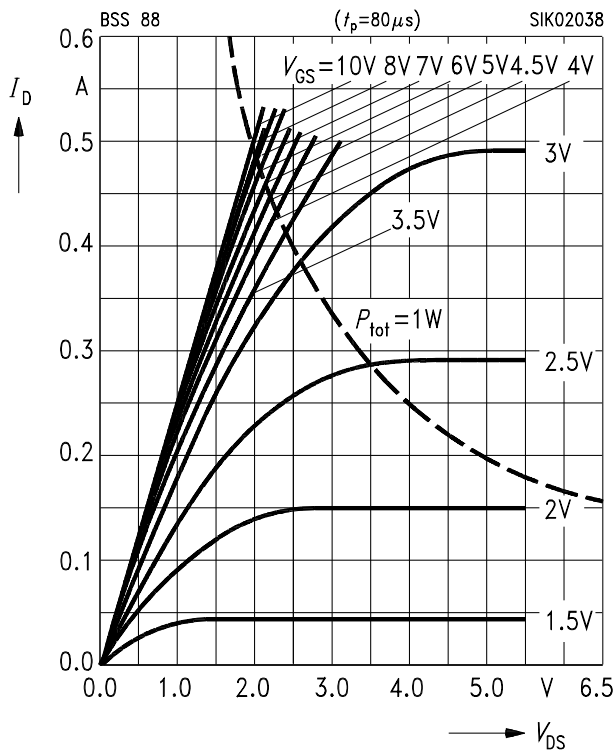

**Typ. drain-source on-resistance**

$R_{\text{DS(on)}} = f(I_D)$

parameter:  $V_{\text{GS}}$

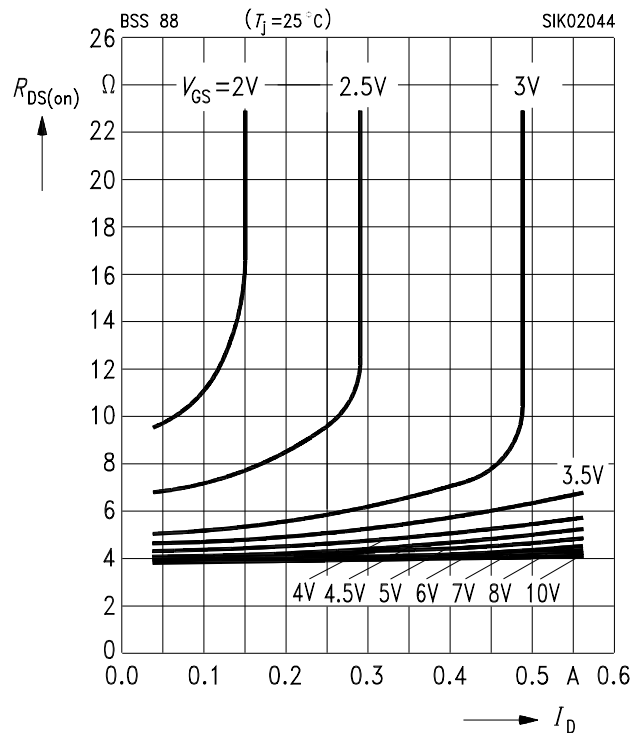

**Typ. transfer characteristics**  $I_D = f(V_{GS})$

parameter:  $t_p = 80 \mu s$ ,  $V_{DS} \geq 2 \times I_D \times R_{DS(on)max.}$

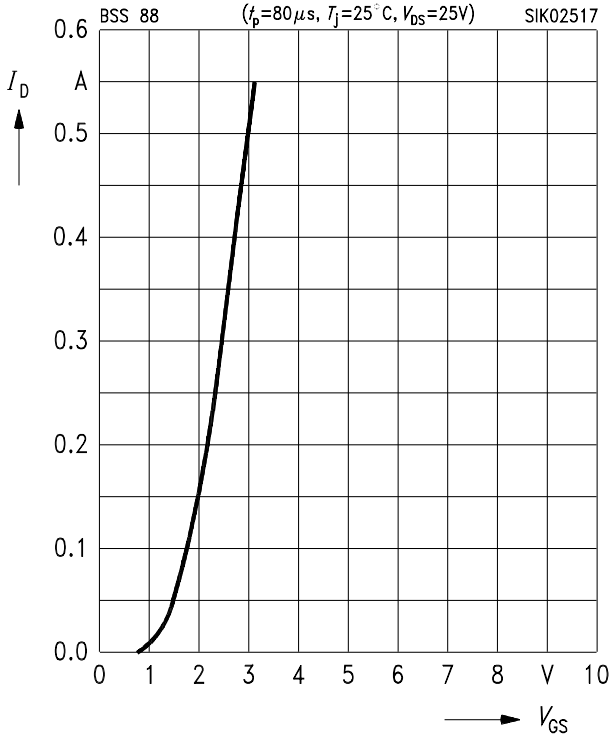

**Typ. forward transconductance**  $g_{fs} = f(I_D)$

parameter:  $V_{DS} \geq 2 \times I_D \times R_{DS(on)max.}$ ,  $t_p = 80 \mu s$

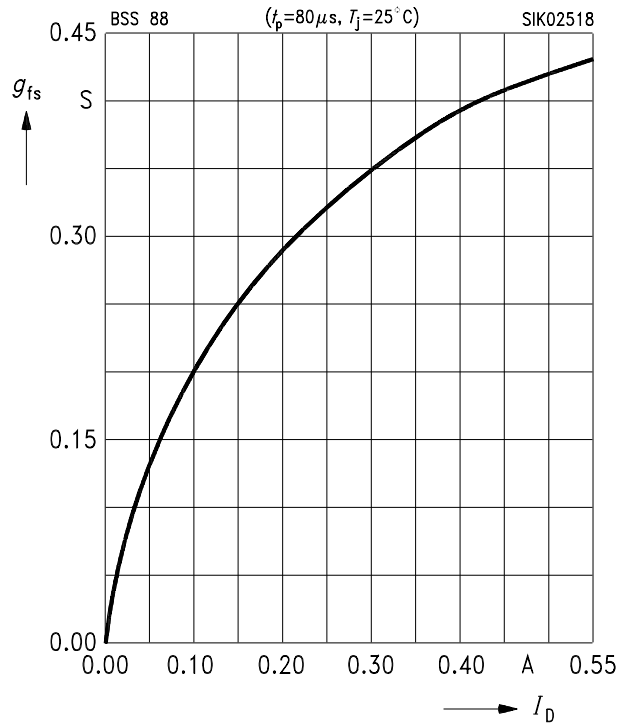

**Drain-source on-resistance**

$R_{DS(on)} = f(T_j)$

parameter:  $I_D = 0.25 A$ ,  $V_{GS} = 4.5 V$ , (spread)

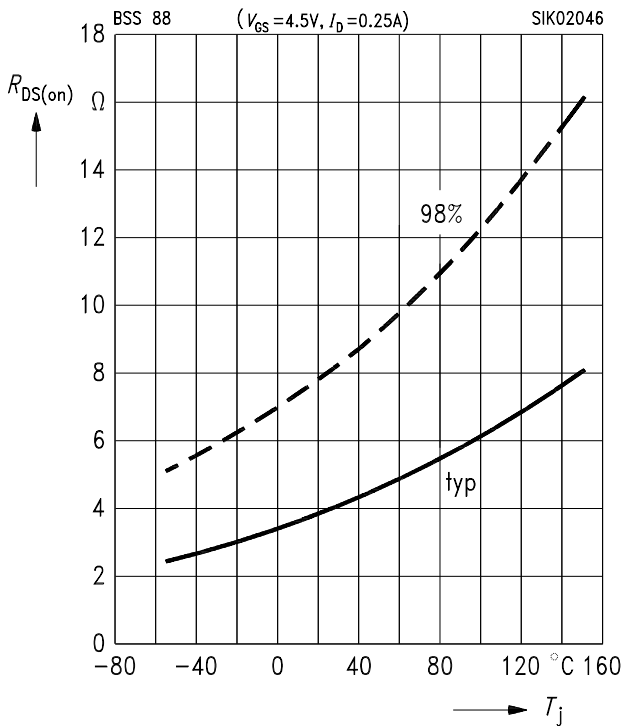

**Typ. capacitances**  $C = f(V_{DS})$

parameter:  $V_{GS} = 0$ ,  $f = 1 MHz$

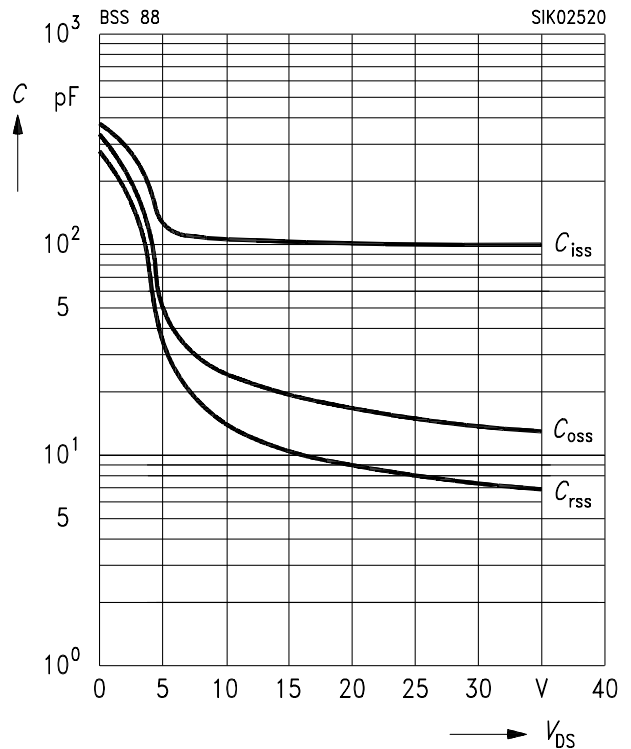

**Gate threshold voltage**  $V_{GS(th)} = f(T_j)$   
 parameter:  $V_{DS} = V_{GS}$ ,  $I_D = 1 \text{ mA}$ , (spread)

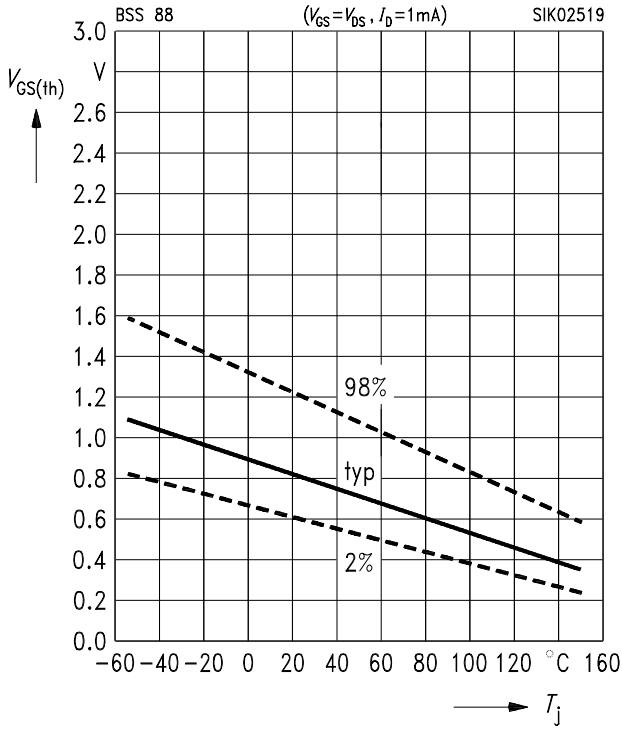

**Forward characteristics of reverse diode**  
 $I_F = f(V_{SD})$   
 parameter:  $t_p = 80 \mu\text{s}$ ,  $T_j$ , (spread)

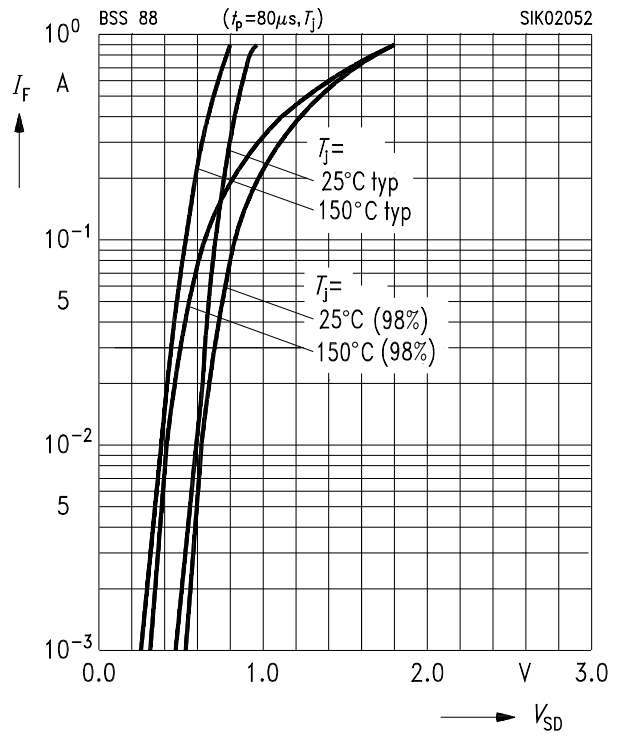

**Drain current**  $I_D = f(T_A)$   
 parameter:  $V_{GS} \geq 5 \text{ V}$

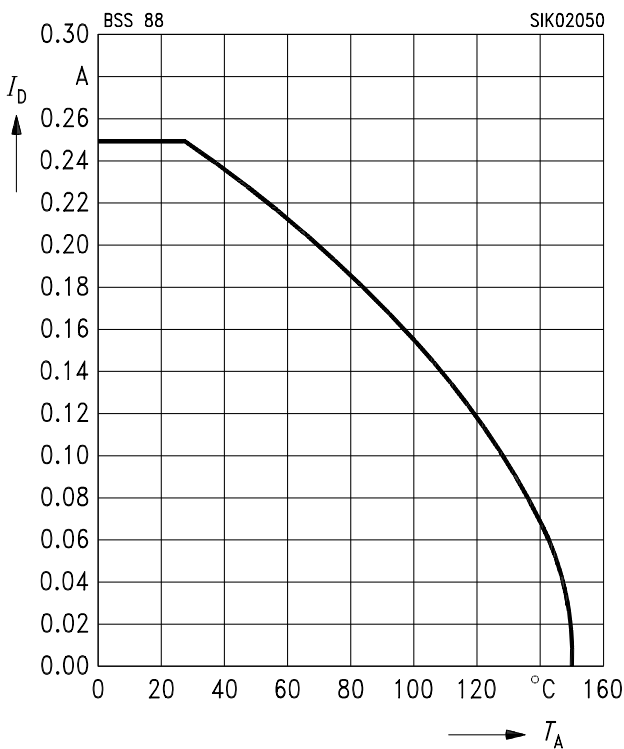

**Drain-source breakdown voltage**  
 $V_{(BR)DSS} = b \times V_{(BR)DSS}(25^\circ\text{C})$

