



Beam Break Kit Datasheet

Beam Break Kit

The Beam Break Kit by Global Laser contains the transmitting and receiving components required to build a laser beam break system. A beam break system is a technology that senses motion by detecting objects passing through a beam of light. To complete the system all you need to do is supply a DC voltage to each component and align the transmitted beam with the receiver optic.

The transmitter is a laser diode module that emits a visible red beam at a choice of output powers enabling you to meet laser safety requirements. It integrates a specially designed drive circuit that automatically modulates the beam at a particular frequency on power up.

The receiver is a laser detection module that synchronises with the accompanying transmitter. It achieves this by only detecting the modulated frequency of the transmitted beam. As a result, it rejects ambient light in addition to light from most other sources.

An LED indicator located on the rear of the receiver illuminates when the beam is detected and the resulting electrical output, viewed via a connection lead, is around 0VDC (TTL logic LOW). If the beam is blocked, the receiver outputs around 5VDC (TTL logic HIGH). This output can be monitored with a test instrument (e.g. oscilloscope), or used to trigger an alarm or switch.

Beam break systems can be used for “event monitoring” to detect intruders or approaching vehicles. They can also be used for counting projectiles or objects passing through the beam (e.g. on a production line/conveyor belt).



Specifications

Transmitter			
Mechanical Information			
Mass (grams)	20		
Dimensions (mm)	15 x 49.5		
Housing	Anodised Aluminium		
External Thread	M12 x 1 pitch		
Connector Type	Flying Leads		
Lead Length (mm)	240 (Other lead lengths available on request)		
Isolated Body	Yes		
Optical Information			
Peak Output Power (mW)	0.36 ± 5%	0.9 ± 5%	4.75 ± 5%
Wavelength (nm)	655 *		658 **
Laser Class	1	2	3R
Bore Sighting (mrad)	≤10 ***		
Adjustable Focus	Yes		
Environmental Information			
Operating Case Temperature (°C)	-10 to +45		
Storage Temperature (°C)	-40 to +85		
Operating Humidity (%RH)	90 (non condensing)		
Electrical Specifications			
Input Voltage (Vdc) (Red Lead - Pin 1)	5 ±5%		
Input Voltage (Vdc) (Black Lead - Pin 2)	0		
Operating Current Drive Circuit (mA)	4 (Typical)		
Operating Current (mA)	10	19	
Reverse Polarity Protection	Yes		
NOTES * Varies between 650-660nm with input voltage ** Varies between 658-666nm with input voltage *** @ factory set focus All specifications are typical @ 25°C			

Specifications

Receiver	
Mechanical Information	
Mass (grams)	50
Dimensions (mm)	15 x 51
Housing	Anodised Aluminium
External Thread	M12 x 1 pitch
Connector Type	4-pin JST
Lead Type	Flying Leads
Lead Length (mm)	500 (Other lead lengths available on request)
Isolated Body	Yes
Optical Information	
Operating Wavelength Range (nm)	400 - 1100
Wavelength of Peak Sensitivity (nm)	900
Minimum Incident Pulse Power (μ W)	40 *
Acceptance angle ($^{\circ}$)	160
Detection range (m)	30 **
Environmental Information	
Operating Case Temperature ($^{\circ}$ C)	-10 to +45
Storage Temperature ($^{\circ}$ C)	-10 to +85
Electrical Specifications	
Input Voltage (Vdc) (Red Lead - Pin 1)	5 \pm 5%
Input Voltage (Vdc) (Black Lead - Pin 2)	0
System Response Time (ms)	3
Minimum Operating Current (mA)	6 ***
Maximum Operating Current (mA)	23 ****
Reverse Polarity Protection	Yes
TTL Logic Output (Blue Lead)	Logic low = 0 V = beam detected
	Logic high = 5 V = No beam detected
NOTES * (λ ~900nm) ** Detects a 0.36mW (Class 1) beam from 30m away. This measurement was limited due to the size of our warehouse, and we expect the actual range to far exceed 30m *** Minimum current occurs when no beam detected. Input voltage 5.00Vdc **** Maximum current occurs when beam detected. Input voltage 5.00Vdc	

Pin Configuration

The receiver achieves immunity to ambient light by exclusively detecting light of a pre-set modulation frequency. A white LED indicator illuminates when the receiver captures a signal of the correct modulation frequency, and pin 4 of the receiver outputs a TTL logic low signal (≈ 0 V). Otherwise, pin 4 of the receiver outputs a TTL logic high signal (≈ 5 V).

The receiver is fitted with a connector and 4 flying leads, configured as follows:

Detector Pin	Lead	Connection
1	Red	+5V Supply
2	Black	0
3	Yellow	None (leave floating)
4	Blue	TTL Signal Out

The transmitter is fitted with a connector and 2 flying leads, configured as follows:

Laser Pin	Lead	Connection
1	Red	+5V Supply
2	Black	0

Relative Sensitivity

The graph below shows the sensitivity of the receiver as a function of wavelength. The Beam Break Kit is supplied with a 655/658nm (typ) laser transmitter as standard. If you require increased sensitivity, we can change your laser to infrared.

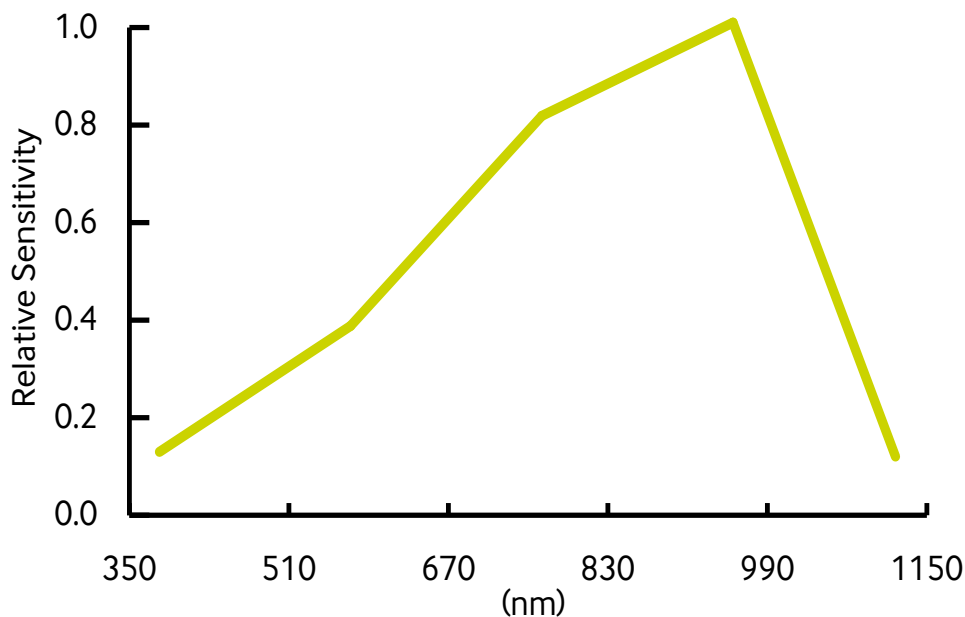

Mounting Options

The M12 x 1 threaded body of both the transmitter and receiver provides a stable and convenient mounting method which enables effective heatsinking to maximise the operating life. The metal body should be in good thermal contact with the mount, which should not be allowed to exceed the maximum case temperature. Global Laser provides the following mounting accessories:

Heavy Duty Mounting Clamp

The Heavy Duty Clamp has horizontal and vertical angular adjustment that allows you to aim the laser or detector in the required direction. The robust aluminium construction conducts heat and prevents movement due to shock and vibration. The base of the clamp has a series of threaded holes that allow it to be securely fastened to a machine or workbench.



Heavy Duty Mounting Clamp
Global Laser Part Number - 1240-17-000
RS Part Number - TBC

Swivel Mounting Clamp

The swivel clamp provides 180° tilt movement and $\pm 45^\circ$ swivel. Its base has a series of holes that allow the swivel clamp to be fixed directly onto a machine or workbench.



Swivel Mounting Clamp
Global Laser Part Number - 1200-00-000
RS Part Number - RS213-3641

Laser Safety

Our lasers are compliant to IEC 60825-1:2014 standards. The lasers fall within one of the following classifications depending on power and wavelength. Examples of the labels are shown below.

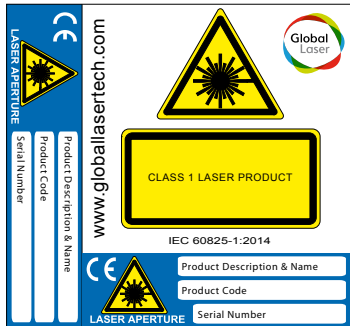

Class 1 Label

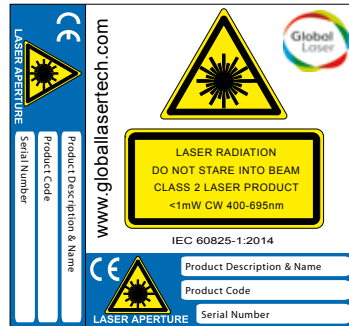

Class 2 Label

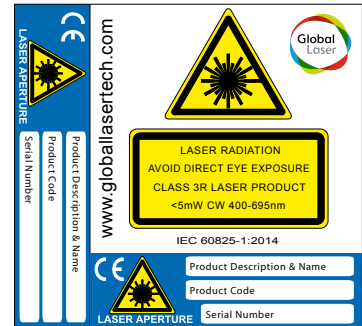

Class 3R Label

Quality & Warranty

The Beam Break Kit is supplied with a 12 month parts and labour warranty. Our manufacturing operations are certified to ISO9001:2015.

Mechanical Dimensions

Varilite Laser

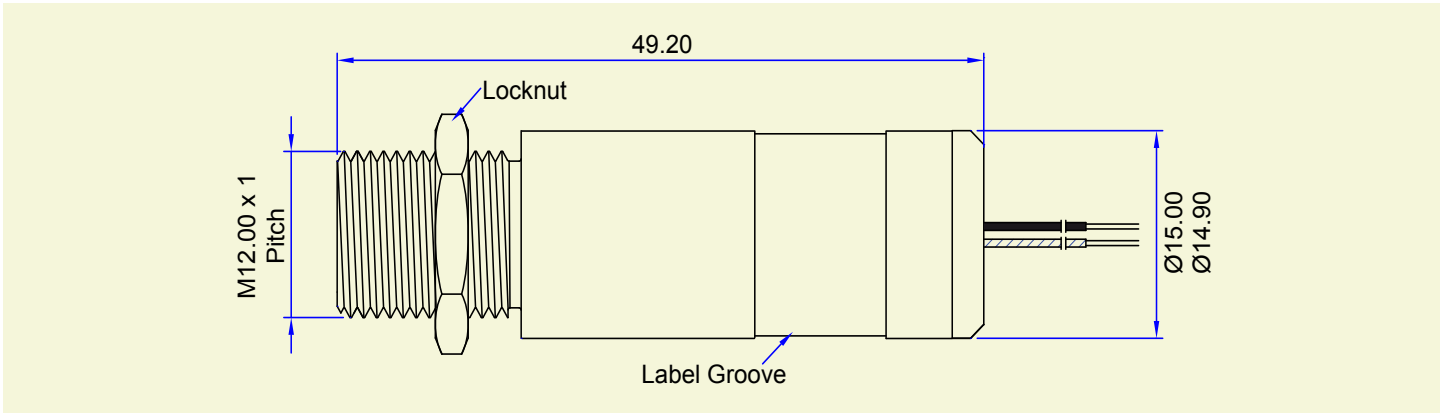

Synchronous Detector

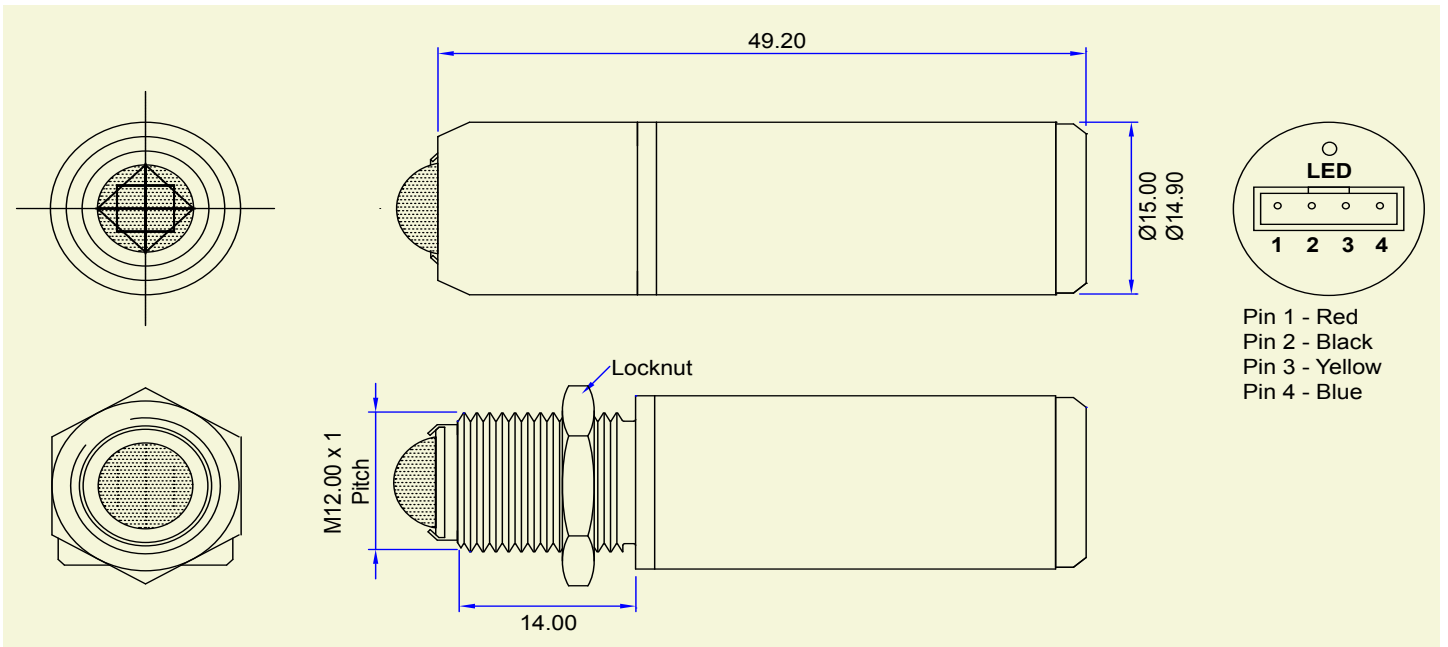

Drawings not to scale

Please note: Global Laser reserve the right to change descriptions and specifications without notice.

