

REV.	LTR	ECN/DESCRIPTION	DATE
1.0		NEW TYPE	2015/3/30

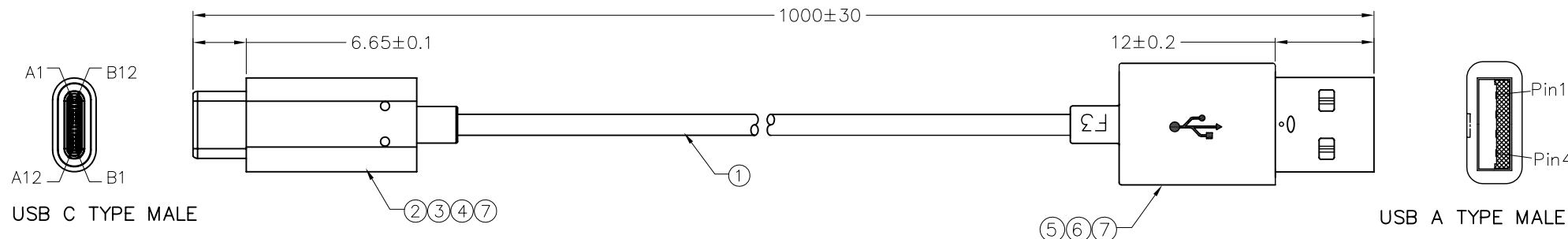

PIN ASSIGNMENT:

	USB C TYPE		USB A TYPE MALE	
GND	A1,B1,A12,B12	—————	4	Black (Ground)
VBUS	A4,B4,A9,B9	—————	1	Red (VBUS)
CC	A5	————— Rp		
Dp1	A6	—————	3	Green (USB D+)
Dn1	A7	—————	2	White (USB D-)
BRAID	SHELL	—————	SHELL	BRAID

NOTE

1. OPEN/SHORT/INTERMITTENCE 100% TEST.
2. HI-POT:100V AC/0.1SEC.
3. INSULATION RESISTANCE:300V DC/0.1SEC, 5MΩ MIN.
4. Pin A5 (CC) of the USB Type-C plug be connected to VBUS through a resistor Rp .
Rd=10KΩ±5% .
5. CONDUCTIVE RESISTANCE:3Ω MAX.
6. RoHS COMPLIANT.

⑦	外模	70P PVC BLACK	A/R	KG
⑥	內模	LDPE	A/R	KG
⑤	CONN.2	USB 2.0 A/M 短体一體式 焊線 黑膠 端子鍍金15U"	1	SET
④	馬口鐵	USB C TYPE PLUG 馬口鐵下殼.	1	SET
③	馬口鐵	USB C TYPE PLUG馬口鐵上殼.	1	SET
②	CONN. 1	USB C TYPE PLUG 端子鍍金30U',黑色膠芯.	1	SET
①	CABLE	UL2725 28AWG*1P+24AWG*2C+AB BLACK PVC OD=3.5±0.2MM	A/R	M
NO.	NAME	MATERIAL DESCRIPTION	O'TY	UNIT



CUSTOMER DRAWING		GENERAL TOLERANCES UNLESS SPECIFIED		APPROVED BY:	TITLE: USB C TYPE PLUG to USB 2.0 AM
SIZE	UNITS	X±0.50	X*±5.0°	CHECKED BY:	
A4	MM[INCH]	.XX±0.35	.X*±3.0°		
SCALE	REV.	.XX±0.25	.XX*±2.5°	DESIGN BY:	RS P/N
NONE	1.0	.XXX±0.15	.XXX*±2.0°		3008950499
				SHEET	1/1

