



Instruction Manual

RS-606584/ 606593/ 606594/ 606595/

606596/ 606597/ 606598

Digital Force Gauge



Please read this manual before using the instrument



Digital Force Gauge/English

Contents

1.Introduction.....	4
2.Product List.....	6
3.Name of each part	7
4.Accessories	11
5.Installation.....	11
5-1-1. Installation accessories	11
5-1-2. Test bed installation.....	12
5-1-3. Power supply recharging	12
6.Basic operation of force measurement.....	12
6-1.Introduction to standard status buttons	13
6-1-1.Peak mode	13
6-1-2.Tracking mode.....	13
6-1-3.Power on /off.....	13
6-1-4.Reset zero	13
6-1-5.Peak mode	13
6-1-6.Unit conversion	13
6-1-7.Precautions in measurement.....	14
6-2.Function setting status (SET) key introduction	14
6-2-1.Setup key details.....	15
6-3.Storage and analysis data status button introduction.....	17
6-3-1.Details of each setting key	18
6-4.Delete storage unit data	21
6-5. Gravity acceleration adjustment	21
6-6.Metrological correction	21
6-7.Restore factory settings	22
7. USB output (FK Series).....	22
7-1-1. Operating environment.....	22
7-1-2 Product connection.....	22



Digital Force Gauge/English

7-2 Software installation	22
7-3. Output connector	22
7-4. RS232C.....	23
7-5. Analog output	24
7-6. Data output	24
7-7. Other inputs and outputs.....	24
8. Repair and calibration.....	25
8-1. guarantee.....	25
9. Specifications.....	26
10. The experimental station.....	27
11. Optional accessories.....	27
12. Optional products.....	27
13. FK series electronic system software.....	28
14. Size.....	28



Digital Force Gauge/English

1.Introduction

Thank you for using FK series digital force gauge. This product series is small, light, ergonomic design. With anti-skid rubber handle and solid metal shell structure, the sensor can withstand 120% overload, and has a variety of functions to measure different tension and pressure of the force measuring instrument. The product is extremely reliable.

FK series digital force gauge is the latest new digital force gauge. FK series digital force gauge is divided into two types: internal sensor and external sensor. There are 12 models from 5N to 3000n for FK internal sensor, 100N to 3T for DS2 external sensor, and 10 models in total.

FK series digital force gauge is suitable for large load measurement. Compared with the previous models, its function and performance have been greatly improved, providing fast services for different measurements. The instrument has real-time tracking test and two peak modes to choose from. The measurement units are KGF (GF), LBF, (k) n to choose from. The LCD screen can flip to display the measurement data and units. The super memory storage function can store 999 test values, automatic shutdown time setting, battery capacity display, measurement correction, high precision and high resolution, Four test modes and three display modes are available for selection, comparative statistics function and data output function. Test data can be input into computer through data line for various analysis.

In order to get the most benefit from this instrument, please read the operation manual carefully before use. If there is any problem with the product, please put forward to your dealer or contact the Sales Department of our factory as soon as possible.



Caution

 To bend or twist Incorrect direction Overload

- Please keep in mind that the instrument will be damaged no matter whether the power supply is off or on and the force used will exceed the load capacity;
- If the force used exceeds 110% of the full range, the warning LED will flash. In this case, please stop the force immediately;
- Please use the force in the direction of the measuring shaft of the instrument. If the bending or twisting force is applied, the sensor will be damaged.

Precautions for use

This instrument is only used for measurement.

- Read the manual carefully before using this product. Use in accordance with the instructions.
- Avoid misuse or rough treatment.
- Do not disassemble or damage the product.

Digital Force Gauge/English

Storage precautions

- Please avoid oil, dust, and high temperature and keep it in a cool place.
- After use, please keep it in the attached instrument box to avoid the measurement shaft being subjected to or vibrated.
- If you want to remove dust from the instrument, do not use organic solutions, such as thinners.
- It also consumes very little current when the power is turned off. If it is not used for a long time, please charge it before use.

Precautions for accuracy assurance

- Although it is based on the operating frequency or force range, the measurement accuracy will gradually decrease. Therefore, we suggest to calibrate the instrument regularly.
- The standard temperature range is 0 °C to 40 °C. For more accurate measurement, please use the instrument within the specified temperature range.

Safety precautions

- wear eye and body protective clothing at all times as debris may pop out during damage, test points, or another test.
- if you want to connect this instrument to the laboratory or other places, please read this operation manual carefully before operation

2.Product List

FK series including FK series have USB output function. Standard type FK has a measurement range of low value 5N to 3000n. The DS2 has a measuring range of 100N to 30000N. There is no sensor inside the split digital force gauge, but an external sensor is used.

Instrument type		Maximum load value	Score value	Sensor structure
Standard type	FK-5N	500g (5N)	0.0001kgf (0.001N)	Built-in type
	FK-10N	1Kgf (10N)	0.001kgf (0.01N)	
	FK-20N	2Kgf (20N)	0.001kgf (0.01N)	
	FK-50N	5Kgf (50N)	0.001kgf (0.01N)	
	FK-100N	10Kgf (100N)	0.001kgf (0.01N)	
	FK-200N	20Kgf (200N)	0.01kgf (0.1N)	
	FK-500N	50Kgf (500N)	0.01kgf (0.1N)	
	FK-1000N	100Kgf (1000N)	0.1kgf (1N)	
	FK-2000N	200Kgf (2000N)	0.1kgf (1N)	
	FK-3000N	300Kgf (3000N)	0.1kgf (1N)	
Split type	DS2-100N-XD	10Kgf (100N)	0.001kgf (0.01N)	
	DS2-200N-XD	20Kgf (200N)	0.01kgf (0.1N)	
	DS2-500N-XD	50Kgf (500N)	0.01kgf (0.1N)	
	DS2-1000N-XD	100Kgf (1000N)	0.1kgf (1N)	
	DS2-2000N-XD	200Kgf (2000N)	0.1kgf (1N)	
	DS2-3000N-XD	300Kgf (3000N)	0.1kgf (1N)	
	DS2-5000N-XD	500Kgf (5000N)	0.1kgf (1N)	
	DS2-10KN-XD	1000kgf (10KN)	0.1kgf (1N)	
	DS2-20KN-XD	2000kgf (20KN)	0.1kgf (1N)	
	DS2-30KN-XD	3000kgf (30KN)	0.1kgf (1N)	
	DS2-50KN-XD	5000kgf (50KN)	0.1kgf (1N)	

- ◆ The resolution varies with the scale.
- ◆ No attachments are included in the DS2 split type or higher. There are no measurement axes in these modes.

3.Name of each part

FK series general switch and display diagram

Digital Force Gauge/English



Function

ON/OFF	Switching Mode Power Supply
ZERO	Clear display value
PEAK	Peak mode and trace mode
SET	Under the standard use mode, it is the unit conversion key. Long press for 6 seconds to set the maximum value, minimum value and alarm value
RS232	By connecting to a variety of optional power supplies, data can be transmitted to a computer, or measurement results can be recorded to a data processor or a record book.
	The storage capacity of the battery is three bars at full capacity. If the battery is insufficient, it will flash. Please charge in time. The battery needs

	to be turned on and off before charging
-NG +NG	OK -NG means that the alarm will be given if the value is lower than the minimum value (generally set as 0), OK means the normal test state, and +NG means the alarm will be given if the value is higher than the maximum value
Overload LED	If the maximum force measurement value exceeds 110% of F.S., the red light will flash.
USB interface	Plug in the USB disk and copy the stored data

Display part introduction

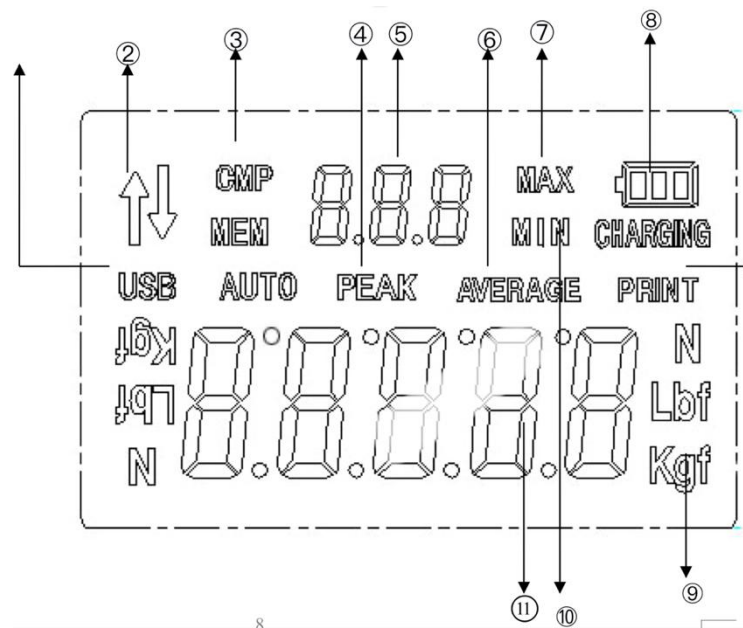

① USB access flag bit, when USB is displayed, it indicates that there is a USB access.

② Push pull (thrust) mark, indicating pull force (display symbol is positive) and thrust (display symbol is negative).

③ CMP alarm comparison value flag, which is displayed when the alarm value is set.

④ Peak peak state, indicating that the peak state is entered, and the auto peak state is displayed at the same time.

⑤ In the sub display area, the measured damping coefficient is displayed in the normal mode (standard mode), the number of stores is displayed in the data storage mode, and the corresponding function indication such as set is displayed in the setting mode.

⑥ Average value display, when displayed, the value displayed in the main display area is the average value.

⑦ Max max value: when in the storage and analysis data mode, Max is displayed. At this time, the main display area displays the maximum value of the measured data.

Digital Force Gauge/English

When in the setting mode, Max is displayed, and the upper limit comparison value is set.

⑧ The battery capacity detection display is divided into three grids, respectively representing high, medium and low power. When the power is low, the outer frame flashes. When there is an external power supply, the charging display.

⑨ Unit display area, displaying the current unit.

⑩ Min minimum value: when in the storage and analysis data mode, min is displayed. At this time, the main display area displays the minimum value of the measured data; when in the setting mode, min is displayed, and the lower limit comparison value is set.

⑪ The main display area is a 5-bit display area, which displays the measured value.

Independent sensor mode DS2

DS2 has no sensor in the host, but it can connect an external sensor and use it.





- The display device needs to be adjusted according to the sensor, so the device can not connect two or more sensors.
- Please connect the accessory connection of the sensor.
- The connector must be connected from the right direction, please do not insert it with force.

4.Accessories

The following accessories are included in each series. Please keep it in the instrument box.

FK/ DS2

- ◆ Operation manual
- ◆ Check the warranty card and certificate
- ◆ AC charger
- ◆ Instrument box
- ◆ CD (test software)
- ◆ Connecting cable (RS-232C / option USB)



Test the first 5

5.Installation

5-1-1. Installation accessories

Fix the test head accessories on the test shaft. When it is necessary to install the accessories in a certain direction, use an attached nut to fix the accessories.

Digital Force Gauge/English



- Force from the wrong direction or use tools to install accessories will cause damage to sensor parts. For safety reasons, please install accessories when checking the display.
- The weight of accessories is applied to the sensor with equal force. We should push the weight of accessories or the weight of clamps under 10% of the instrument capacity.

5-1-2. Test bed installation

This instrument can be connected to the test bench. In this case, please use M4 screw with four holes to connect the instrument from the side.



- When installing FK series, please select suitable M4 × 6 screws, and the depth of access shall not exceed 6mm.
- When installing DS2 series, please make sure to use appropriate accessories.

5-1-3. Power supply recharging

When the internal lithium battery is low, the warning sign "" will flash. Shut down in about 1 minute. At this time, the external power supply shall be applied for charging, and the battery shall be fully charged within 8 hours of charging (the default is 4 hours of charging). Do not use an AC adapter that is not attached to the instrument.

(plug in the adapter and the instrument to start the machine automatically before charging, and then shut down the machine for charging. After the machine is shut down, the charging mark will appear on the screen.)



- The battery charging / discharging life is about 500 times. When the battery is about to run out, the "" will flash shortly after the battery is recharged. In this case, the battery must be replaced. The battery cannot be replaced by the customer. Improper operation may easily cause damage to the instrument.

6. Basic operation of force measurement

A brief description; the force acting on the axis direction of the measurement axis. The measurement is carried out in peak mode or tracking mode. In order to operate conveniently in different use states, the measuring instrument can be divided into three use states: standard state (common state), function setting state, storage and analysis data state.

- Standard state: in normal state, under this state, it has the most commonly used functions. The four keys are respectively, "on / off" key is the power on / off key, "peak" switch in tracking mode and peak mode, "zero" reset key, "send" key is the unit conversion key.

- Function setting state: when entering this state, alarm value setting, upper and lower limit comparison value setting, automatic shutdown time setting for unmanned operation, peak time setting for automatic clearing, measurement sampling frequency setting, and on / off setting for key sound can be performed.
- Storage and analysis data status: enter this status, you can store the current peak value, view the stored peak data, view the minimum, maximum and average value of the stored peak data, and set whether to print out the data.

6-1.Introduction to standard status buttons

6-1-1.Peak mode

Brief description: record the peak value of all test times (the stored value is the peak value). This is useful to provide the maximum instantaneous value reading in fracture test, impact test and other tests.

6-1-2.Tracking mode

Brief description: track process test values. This is useful to provide changes in force readings when using the software.

6-1-3.Power on /off



Press the  key to switch the power on and off.

6-1-4.Reset zero

Clear the indicated value and return to zero. In the standard state, press the  key to clear the indicated value and return to zero.

※During the test, reset the zero value before applying the force and starting the measurement.

6-1-5.Peak mode

Used to measure the maximum value. When the  key is pressed, the "peak" flag will be displayed on the screen, and the status is peak mode. If the "peak" flag does not appear, it indicates that the force value applied to the measuring axis is tracking mode. In the standard state, whenever the  key is pressed, it will switch between "PEAK" and "AUTO PEAK" and "trace" (without "peak") mode in turn.

6-1-6.Unit conversion

In the standard state, when you press the  key, the units will be switched in turn. The switching order is: Kgf(gf)->Lbf->N.

Digital Force Gauge/English

6-1-7.Precautions in measurement



- If the force exceeds 110% of the full range, the overload warning LED will flash. In this case, stop applying the force immediately. Please check for any abnormal conditions before using again. No matter whether the power supply is on or off, the application of overload force will lead to inaccurate measurement or damage to the sensor.
- If the force is applied in the wrong direction of the measuring shaft of the instrument, even within the allowable range of force, it will cause damage.
- Please don't use accessories by mistake. If the force is applied to the end of the hook, the hook will deform or break, which is very dangerous.
- Always wear eye protection when there is damage or a test where debris may fly out.

6-2.Function setting status (SET) key introduction

To enter the function setting state in the standard state, just press and hold the



key for 3 seconds. When the overload LED is on, release it, and enter the function setting state.



- When entering the function setting status in the standard status, the unit displayed in the function setting status is the unit before entering the function setting status. After entering the function setting status, the unit conversion is not available, so adjust the appropriate unit before entering.
- Peak conversion is not available. When entering the function setting state, the "PEAK" key becomes the "add" key.
- Clear is not available. When entering the function setting state, the "Zero" key becomes the minus one key.

Press the  key to set them respectively:



- ① Alarm comparison value setting
- ② Lower limit comparison value setting
- ③ Upper limit comparison value setting
- ③ Time setting of unmanned automatic switch on (P.OF)
- ④ Peak automatic peak clearing time setting (R.PE)
- ⑤ Damping mode setting (sampling rate setting) → {"000" "001" "002" "003"}
- ⑥ Button sound mode: on / off of sound, on means on sound, off means off sound, press peak or zero to select on / off

Cycle from ① to ⑥ above, only press the long key  for 3 seconds to exit but exit the function setting state.



- Note: for all keys, the time cannot be too long, more than seven seconds, which may lead to lifting.

- If the key is too short, the corresponding prompt will not appear in the sub display area after entering the function.

- If the measurement system is in a dead state, press key  or key  for 10 seconds to exit the dead state. (or contact customer service, note the number, open the four screws on the back cover of the instrument, unplug the battery plug inside for a few seconds, plug it back in the original direction, the direction can't be changed, just start the machine).

6-2-1.Setup key details











◆ Press key  for 3 seconds to enter the function setting state (set), and the screen will first display as shown in Figure 1. This is the alarm comparison value setting interface. As long as you press  to add,  to subtract, and do not set the alarm comparison value, press  to enter the next settings, and the alarm comparison value will be saved.





figure1

◆ Press the  key for the second time to enter the lower limit comparison value setting, "CMP" disappears, "Min" appears. As long as you press the  key for the addition and  key for the subtraction, without setting the lower limit comparison value, press the  key to enter the next setting, and the lower limit comparison value will be saved. (the general lower limit is 0, not recommended)

◆ Press the  key for the third time to enter the upper limit comparison value setting, "Min" disappears, "Max" appears. As long as you press the  key for addition and  key for subtraction, without setting the upper limit comparison

Digital Force Gauge/English

value, press the  key to enter the next setting, and the upper limit comparison value will be saved.

◆ Press key  for the fourth time to enter the power off setting of unmanned operation automatic machine, and "Max" disappears. The screen displays as shown in Figure 2.



as long as you press key  for addition and key  for subtraction, without setting the operation start-up time, press key  to enter the next setting and save the no operation start-up time setting (default is 10 seconds).



Figure 2









◆ Press key  for the fifth time to enter peak peak automatic clearing time setting (repeat peak). The screen display is as shown in Figure 3. As long as you press key  for addition and key  for subtraction, without peak automatic clearing time setting, press key  to enter the next setting and save the peak automatic clearing time setting (default is 3 seconds).







Figure 3

◆ Press the key  for the sixth time to enter the damping mode setting, but the sampling rate setting (sample). The screen display is as shown in Figure 4. As long as you press the key  for the addition and the key  for the subtraction, without damping mode setting, press the key  to enter the next setting, and the damping mode setting will be saved (the default is 000 mode). Among them, the conversion is from 000-001-002-003, 000 mode = 1000 sampling rate / s, 001 mode = 250 sampling rate / s, 002 mode = 63 sampling rate / s, 003 mode = 50 sampling rate / s.

Use the 000 mode for impact testing or for quick strength testing.



figure 4

◆ Press key  for the seventh time to enter the key sound mode. The main display area displays "SOUND". When the key sound is turned on or off, ON means the sound is turned on, OFF means the sound is turned off. Press  or  for on / off selection. After the seventh time, it will automatically return to the first time and set the alarm value until the  key is pressed for 3 seconds. When the OVERLOAD LED is on, release it to exit the function setting state.

6-3.Storage and analysis data status button introduction

To enter the storage and analysis data status in the standard state, just press and hold the a key for 3 seconds continuously, and when the OVERLOAD LED is on, release it to enter the storage and analysis data status. This state is suitable for data storage, data analysis and data printout. You can enter this state when you need these functions. This state is the same as the standard state, but the unit and peak value, automatic peak value or tracking mode shall be adjusted before entering, and cannot be adjusted after entering.



- In the standard state, when entering the state of data storage and analysis, the unit for storing and analyzing data status display is the unit before entering storage and analyzing data state, and the unit after entering is not available, so enter the unit before entering.
- The peak conversion is not available, and enters the storage and analysis data status. The "peak" key becomes the function switch key of storage and analysis data status.

Press the  key to sequence the functions as follows:

- ① The peak data can be stored up to 999.
- ② Query the data stored in the storage unit (RAM).
- ③ Find the minimum value in the stored data.
- ③ Find the maximum value in the stored data.
- ④ Calculate the average value in the stored data.
- ⑤ To select whether to print out, press "ZERO" key to switch OFF/ ON.

Digital Force Gauge/English

Cycle from ① to ⑤ above, only long press a key for 3 seconds to exit but exit the function setting state.

6-3-1.Details of each setting key

◆ Press key  for 3 seconds to enter the storage and analysis data status, and the screen will first display as shown in figure-5, which is the storage data interface. The "MEM" on the screen represents memory, and the sub display area displays the current number of stored data, which is 001 in the figure (there is no data in the unit). The main display area displays the measured value, which is currently 0.000Kgf。 To enter the data storage, measure a peak value. To store the value in the ram of the storage

unit, press , and the value will be stored in the storage unit. Add 1 to the value of the sub display area (the number of storage plus 1, if it starts from 001, it will be 002 after the test is stored, and so on), and clear the line. Of course, the measured value can be stored or not stored in the unit. When it is not stored in the storage unit, just press the

 key to clear the data, the current measured value will be abandoned, not stored, the test will return to zero, and the value of the sub display area will not change (the number of storage will not increase). The above tracking mode and "peak" mode are

applicable. To exit from the storage state, just press the  key once to exit from the storage state. At this time, "MEM" flashes to enter the numerical query state.

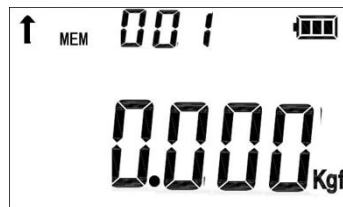









Figure 5



- Note that during measurement, the direction of the first value you store (push or pull) is the direction of the data accessed later. When the measured data is not the same as the direction of the first storage, the value will not be stored, so as to prevent the value not in the same direction from being stored. When you want to change the storage

direction, under the function of data storage, long press the  key for 3 seconds, and then release the OVERLOAD light to delete all the data of the storage unit. During the deletion process, it takes some time (the screen is only frozen for a while). After deletion, the data can be stored, and the first storage direction is used as the standard for storage.

● Before entering the storage and analysis data state, if it is "AUTO PEAK" When peak mode is entered, the stored data will automatically store the value. For each measured value, as long as the peak clearing time is one to three seconds (the default value is 3 seconds), the value will be cleared and stored in the storage unit at the same time. It can also be accessed manually. The method and tracking mode are the same as peak mode. Press  to access and  to give up.

◆ Press the  key for the second time, and enter to view the stored value. At this time, "MEM" flashes. At this time, just press the  key to look forward, and press the  key to look backward. Press the  key to enter the next function to find the minimum value of the stored value.





◆ Press key  for the third time to enter the minimum value of the stored value, and the screen display is as shown in Figure 6. As shown in the figure, "Min" appears on the screen and "MEM" disappears. The sub display area is the number of stored data, and the main display area is the minimum value. Press  to view the unit conversion.



Figure 6

◆ Press key  for the fourth time to enter the maximum value of the stored value, and the screen display is as shown in Figure 7. As shown in the figure, "Max" appears on the screen and "Min" disappears. The sub display area is the number of stored data, and the main display area is the maximum value. Press  to view the unit conversion.

Digital Force Gauge/English



Figure 7

◆ Press key a for the fifth time to enter the average value of the stored value, and the screen display is as shown in Figure 8. As shown in the figure, "AVERAGE" appears on the screen and "MAX" disappears. The sub display area is the number of stored data, and the main display area is the average value. Press B to view the unit conversion.



Figure 8



◆ Press key  for the sixth time to enter whether to turn on the print output and send a data function. The screen display is as shown in Figure 9. As shown in the figure, "PRINT" will appear on the screen and "AVERAGE" will disappear. The secondary display area is "ON" and the main display area is print. Press  key to switch OFF/ ON, ON means on, OFF means off, default is off.





Figure 9







- If you want to exit the storage and analysis data status, no matter what function, just press  key for 3 seconds, and release it when the overload light is on, you can exit.

6-4.Delete storage unit data





In the standard state, long press the  key for 3 seconds, and release when the overload light is on, then all data of the storage unit can be deleted. Or when storing data, long press  key for 3 seconds, and release when overload light is on, then all data of storage unit can be deleted. Do this before storing and analyzing data status. (it will take a little time, please wait)

6-5. Gravity acceleration adjustment

In order to use it in different areas with more accurate accuracy, it can be adjusted according to the acceleration of gravity in this area. This adjustment will affect the measured data. In the shutdown state, press and hold the  key, press the  key at the same time to start the machine, press and hold for about 1 second at the same time, release after the OVERLOAD light is on, and then enter the gravity acceleration adjustment mode. At this time, press the  key to increase 1, and press the  key to decrease 1. After adjustment, press  to save. It will automatically turn on after saving. Factory default is 9.800N。

※This adjustment directly affects the measured value.



6-6.Metrological correction

When the measurement department needs to calibrate the instrument, it can press key  while holding key  for a long time, press key  for 1 second, release when overload light is on, display "full", hang the relative weight of the full range (preferably 110% of the weight of the full range). When there is a weight hanging on, OVERLOAD light will flash, press key  after stabilization, automatically shut down, finish the calibration, and store the calibration data in the instrument Inside. If the correction value is wrong, please return to the factory setting state.

※This correction directly affects the measured value, do not use this function casually.

Digital Force Gauge/English

6-7.Restore factory settings

In the shutdown state, press the  key and then press the  key. When the OVERLOAD light is on, release it. Then the instrument will enter the startup state and return to the factory setting state.

7. USB output (FK Series)

The product can be connected to the personal computer by using the accessory USB cable, install the corresponding USB driver, and install the test software, so that the data can be transferred and managed.

7-1-1. Operating environment

pattern	PC / AT, DOS / V, compatibility mode (CPU 233MHz and above)
Operating system	Microsoft Windows 98SE/2000/ME/XP
port	USB1.1,USB2.0
Memory	64MB RAM and above
Hard disk	400MB

7-1-2 Product connection

Connect the USB port of the push pull meter to the USB port of the personal computer by using the accessory USB cable. After turning on the computer, turn on the power button of the digital force gauge. Next up is the installer.

7-2 Software installation

The test software is in the CD-ROM program of this product (optional). Please contact us for more information. Please watch the software video for installation test.

① Make sure you have a CD-ROM drive installed on your PC. When there is an optical drive, plug in, open, click and run the software.

② When the USB link is used for conversion, the corresponding USB driver needs to be installed.

7-3.Output connector

Digital Force Gauge/English

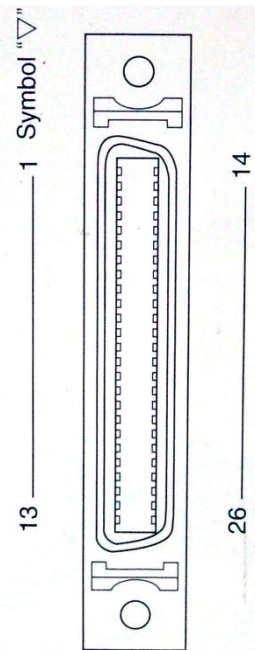

Communication interface pin number	Number name	description
1	TXD	RS232C signal
2	RXD	
3	GND	
4	AOUT	Analog output
5	AGND	
6	NC	Pin is empty
7	TXD2	Send signal 2
8	NC	Pin is empty
9		
10		
11		
12		
13		
14		
15		
16		
17		
18		
19		
20	GND	Electrical grounding
21	+NG	
22	OK	
23	-NG	
24	OVL	
25	COM	
26	COM	

7-4.RS232C

The test software can be installed on personal computer through RS232C optional data line. Data transmission, various settings, can be connected successfully. If it is a USB port, please select com2.

Communication

Port:

Baudrate:

Data out: Specifications

Digital Force Gauge/English

Data bits	8 bits
Transmission rate	2400sps
Stop bit	1 bit
Odd even number	Null

7-5. Analog output

According to the force applied to the measuring axis of the instrument, when the instrument is on, the output analog voltage is about $\pm 2V$ when the maximum value is applied. The CB-104 can be connected with the analog instrument through analog selection, for example / recorder, which can record the transmission value. If the displayed value is ignored, the output of the analog meter indicates the force on the sensor. Therefore, although the display is reset to zero, the output of the analog meter may not be 0V.

7-6. Data output

Connect cb-304 with PC and printer to output data.

7-7. Other inputs and outputs

The output of overload alarm and comparison data is independent of any mode.

All overload alarms and comparison data discrimination signals are open collector outputs.

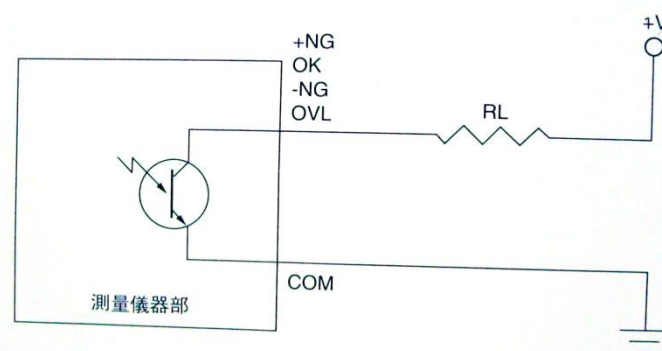

When the measured force exceeds the comparison value, the light source outputs a signal to control the on-off of the 5V relay, so as to realize functions such as motor stop and automatic control; it can also use this signal to realize other control functions, such as inputting the signal into PLC to realize automation. The signal output mode can also be customized, such as output signal within the test force range of a certain section.



- Please keep the original pole voltage lower than DC15V / and 10mA current. If there is no forced connection, it will cause failure.
- OVL: This is an overload signal. Overload signal will be output when using about 110% or above rated capacity.
- + NG, OK, -NG, will sense and compare the data identification result and output.

8. Repair and calibration

Our products are of high precision, so in the process of use, if there is any measurement not on time, it may be caused by incorrect calibration, so when the measuring range is found to be incorrect, you can choose to calibrate or restore the factory settings. Maintain accuracy and reliability of measurement experiments. If there is any problem with the product, we suggest that you ask the local dealer or our company about the situation. If there is any problem with the instrument, please return it to our factory for maintenance, but please make sure the situation of your use and what causes the damage so that we can repair it. When there is a problem with the product, please don't open it by yourself, otherwise we will charge the full amount of maintenance fee. Normally we only charge for mailing.

8-1. guarantee

We guarantee that, within 1 year from the date of delivery, under normal use and reasonable maintenance, the products have no defects in workmanship and raw materials. During the warranty period, we can choose to repair or replace the defective products. Please contact our after-sales customer service to return the defective products together with the prepaid freight to us. (in addition) this warranty does not include externally exposed parts or consumable parts (analogy battery). Neither the seller nor the manufacturer shall be liable for any problem or damage caused by:

- ◆ The warranty card is missing.
- ◆ Neglect or misuse.
- ◆ The problem or damage caused by no measures taken for the foreseeable danger.
- ◆ For use other than measurement.
- ◆ There is no usage specified in the manual.
- ◆ Defects in necessary parts.
- ◆ Remove or damage the product.
- ◆ Replace or use parts other than those specified by the manufacturer.
- ◆ Use a charging adapter that is not included with the instrument
- ◆ Problems caused by the use of other measuring instruments and problems caused by measurement.

Digital Force Gauge/English

9.Specifications

MODE	FK	DS2	
capacity	Product test 6 list		
accuracy	+ 0.5% Full scale + / - 1 bit (number)		
Measuring device	KGF (GF) / LBF / N can be selected		
display	5-digit LCD - device - mode - overload LED LCD - comparison LED LCD (reversible)		
Sampling speed	1000 times / second		
Show updates	10 times <, > 15 times		
Overload capacity	120% of full range (LCD, LED flash and buzzer sound)		
A / D converter	16 bit signal		
microprocessor	8-bit high performance microprocessor		
Endurance time	All charges can be used continuously for about 6 hours, no more than 8 hours		
Charging time	Within 8 hours		
Service temperature	0~50°C		
Humidity range	20% - 80% RH relative humidity		
Power Supply	Internal nimi rechargeable battery, AC adapter		
Output	USB	RS232C	Analog output
	Analog (- 2 to + 2V)		
	Compare signal (- ng, OK, + ng), open collector Max 30V 10mA		
	Over negative alarm output (OVL), open collector Max 30V 10mA		
Peak hold	Pressure or tension		
Comparison function	Settable high and low setpoints with code		
Storage function	999 measurements		
Display flip	Measurements and units of measurement		
Alarm function	Overload and +NG (switch selectable)		
Other functions	Auto clear (1-60 seconds setting)		
	Damped sample frequency mode (4 horizontal settings)		
	Button sound can be turned on or off		
Automatic power off function	1 minute - 60 minutes optional		
External connection switch	Display hold, clear, and peak / trace selection		
Metrological calibration	Self calibration to suit environmental changes		
Acceleration of gravity	Gravity acceleration can be adjusted		
size	length 220.5×width 78 ×height 32.3mm		
weight	About 520g		

※ The instrument can adapt to three kinds of power adapters (110V, 120V, 220V). Please use the original adapter.

10. The experimental station

In order to stabilize the measurement experiment, we recommend using the instrument together with the test bench.

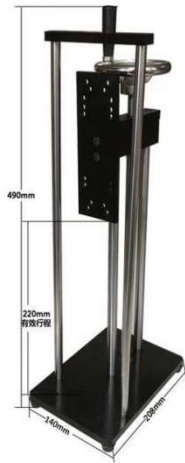

11. Optional accessories

There are various kinds of jigs that can be selected to suit different shapes of samples.



12. Optional products

Software / printer / mini recorder (USB, RS3232)

Z series can connect to PC or printer

13. FK / DS2 series electronic system software

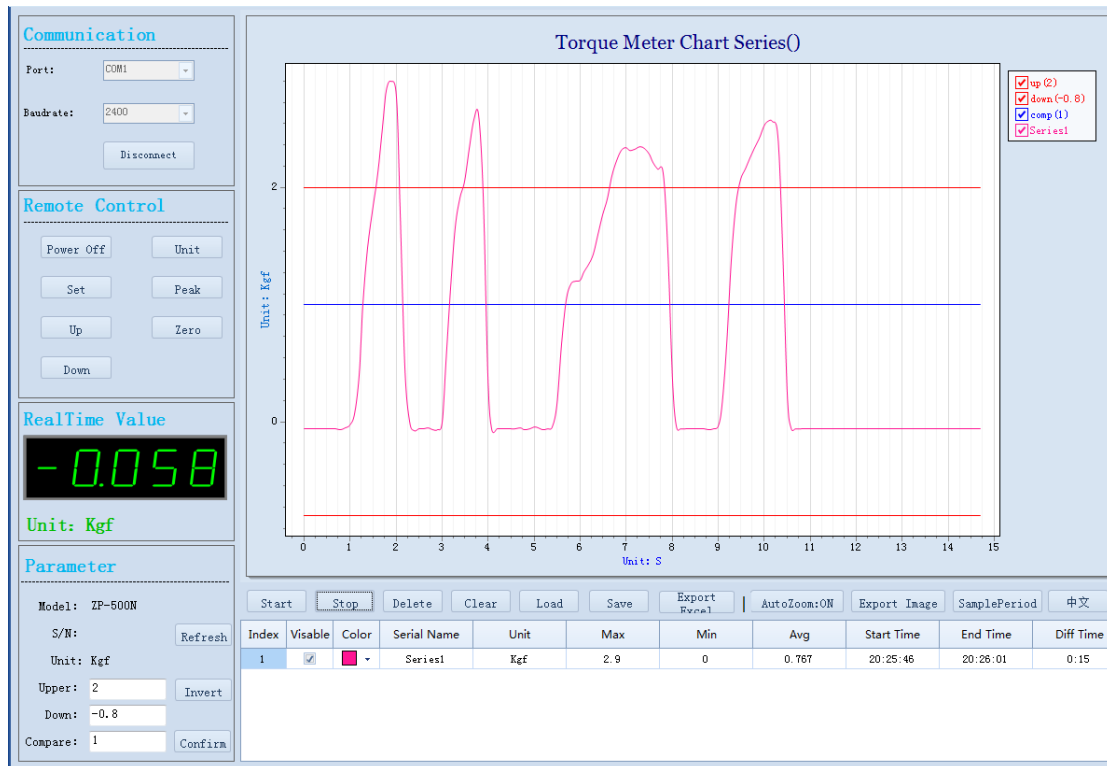

14. Size

FK / DS2 series

※Instrument fixing hole M4 × 16mm (length cannot exceed 16mm, too long will cause damage to the inner motherboard)

Fixed position size 100 × 40mm

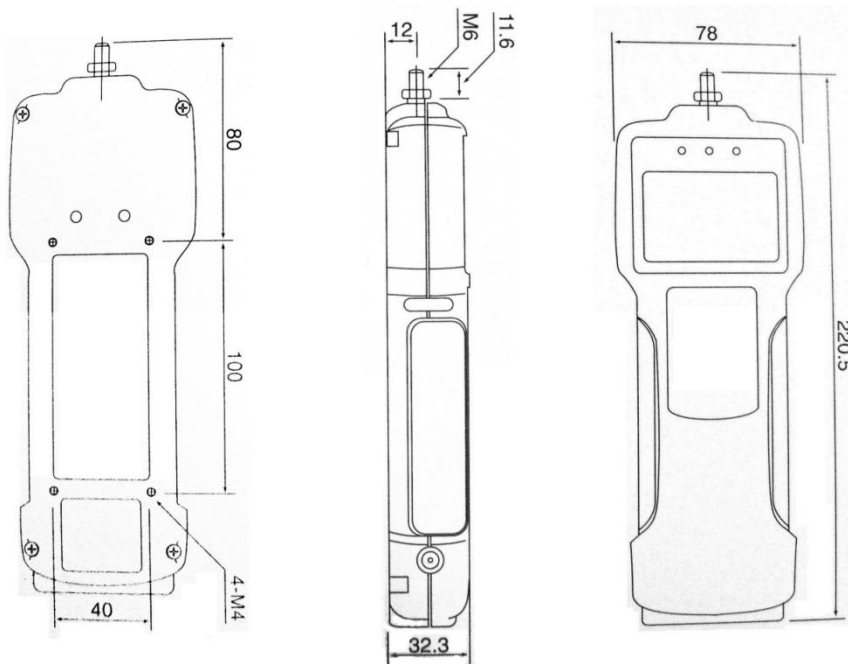



Digital Force Gauge/English

Europe

RS Group plc.

PO Box 99, Corby,
Northants.

NN17 9RS

United Kingdom

www.rs-online.com

South America

RS Group Ltda.

Av. Pdte. Eduardo Frei M. 6001-71
Centro Empresas El Cortijo

Conchali, Santiago, Chile

www.rs-online.com

Africa

RS Group

Vorna Valley, 1686

20 Indianapolis Street,
Kyalami Business Park,

Kyalami, Midrand

South Africa

www.rs-online.com

Middle East

RS Group.

Showroom 4 –

Sheikh Majid Building,

Sheikh Zayed Road,

PO Box 5253 UAE

www.rs-online.com

Australia.

RS Components Pty Ltd

356, 25 Pavesi St, Smithfield.

NSW. 2164 Australia

www.rs-online.com

China

RS Components Ltd.

Unit 501, Building C,

The New Bund World Trade

Center Phase II,

Shanghai, China

www.rs-online.com