

För icke direkt toleranssatta mått gäller toleransklass
General tolerances if not otherwise stated

NOM DIM MM		TOL CLASS		
From	To	A	B	C
(1)	6	±0.05	±0.1	±0.2
(6)	30	±0.1	±0.2	±0.5
(30)	100	±0.15	±0.3	±0.8
(100)	300	±0.2	±0.5	±1.2
(300)	1000	±0.3	±0.8	±2

Hål / Holes H13

Skarpa kanter brutna där ej annat anges.
No sharp edges unless otherwise specified.

Övriga generella toleranser enligt ritning 4100-4644.
Additional general tolerances in accordance with drawing 4100-4644.

MÄRKT ENLIGT RITNING 4101-0261 A
MARKED IN ACCORDANCE WITH DRAWING 4101-0261 A

Rev	Change order	Change: A = Added W = Was D = Deleted	Date	Sign
2	1014994000	4101-0262 ÄNDRAD/CHANGED	021017	SE
3	1016252000	4101-0261A ÄNDRAD/CHANGED	030508	SE

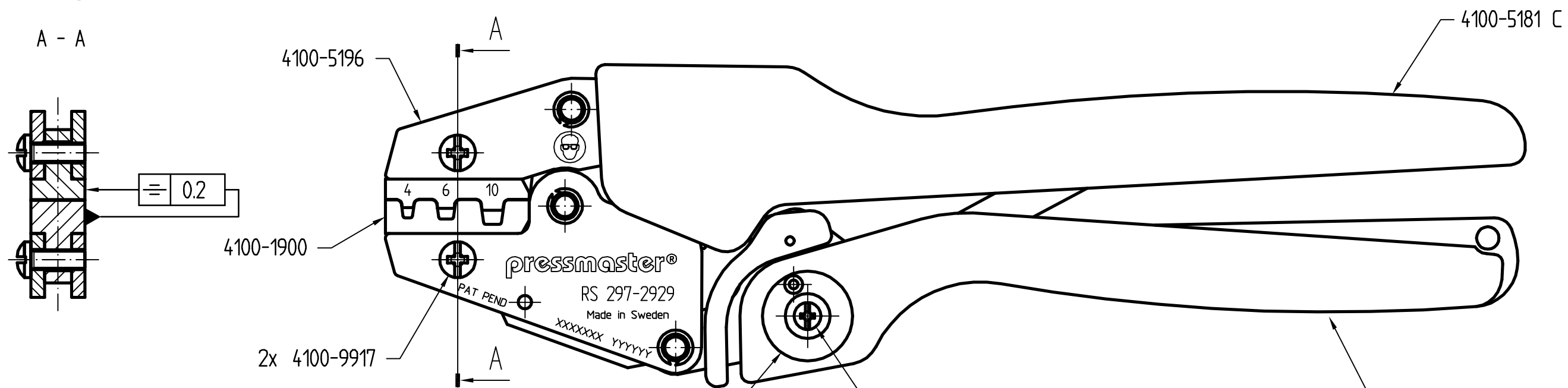
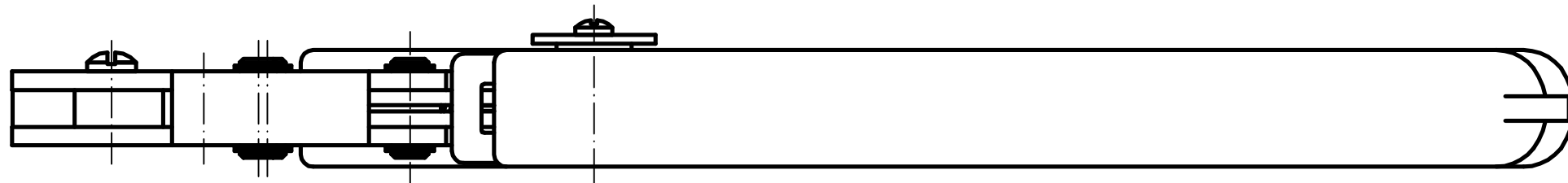

4101-0262
4100-5200
4100-4787

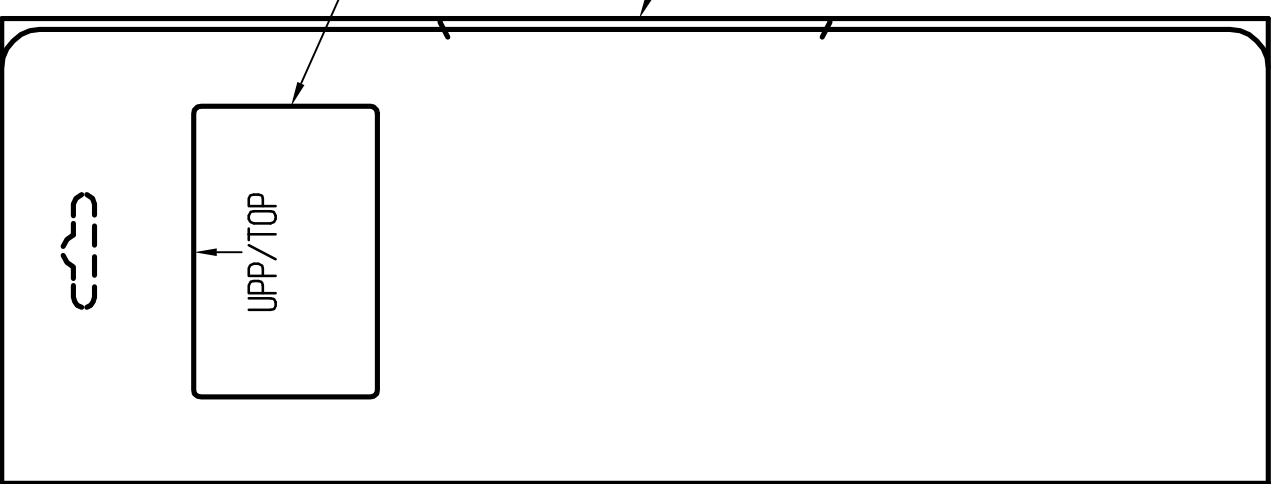

FÖRSPÄNNING / PRELOAD: 120 ± 30 N
Tolkmått / Gauge dimensions (mm)

URTAG NEST	Gåtolk GO	Stopptolk NO GO
4	Ø2.25	Ø2.45
6	Ø2.30	Ø2.50
10	Ø3.10	Ø3.30

Denna ritning är Pressmaster AB:s egendom. Skyddad av gällande lag.
This drawing is the property of Pressmaster AB. Protected in accordance with prevailing law.

Material		Behandling/Treatment			Status PreLutc.	
Konstr./Design MN	Ritad/Drawn LJ	Datum/Date 980416	Skala/Scale 1:1	Kontr./Checked	Godk./Approved	Anne/Blank
pressmaster®				Beräkning/Denomination Krimptång 297-2929 CRIMPING TOOL		Vikt/Weight, gram Art grp 012
ISO 9001 REG NR FM13687				Ritn nr/Drawing no 43002429		REV 003