

543910 DGSL-4-10-PA Mini slide - Series: All

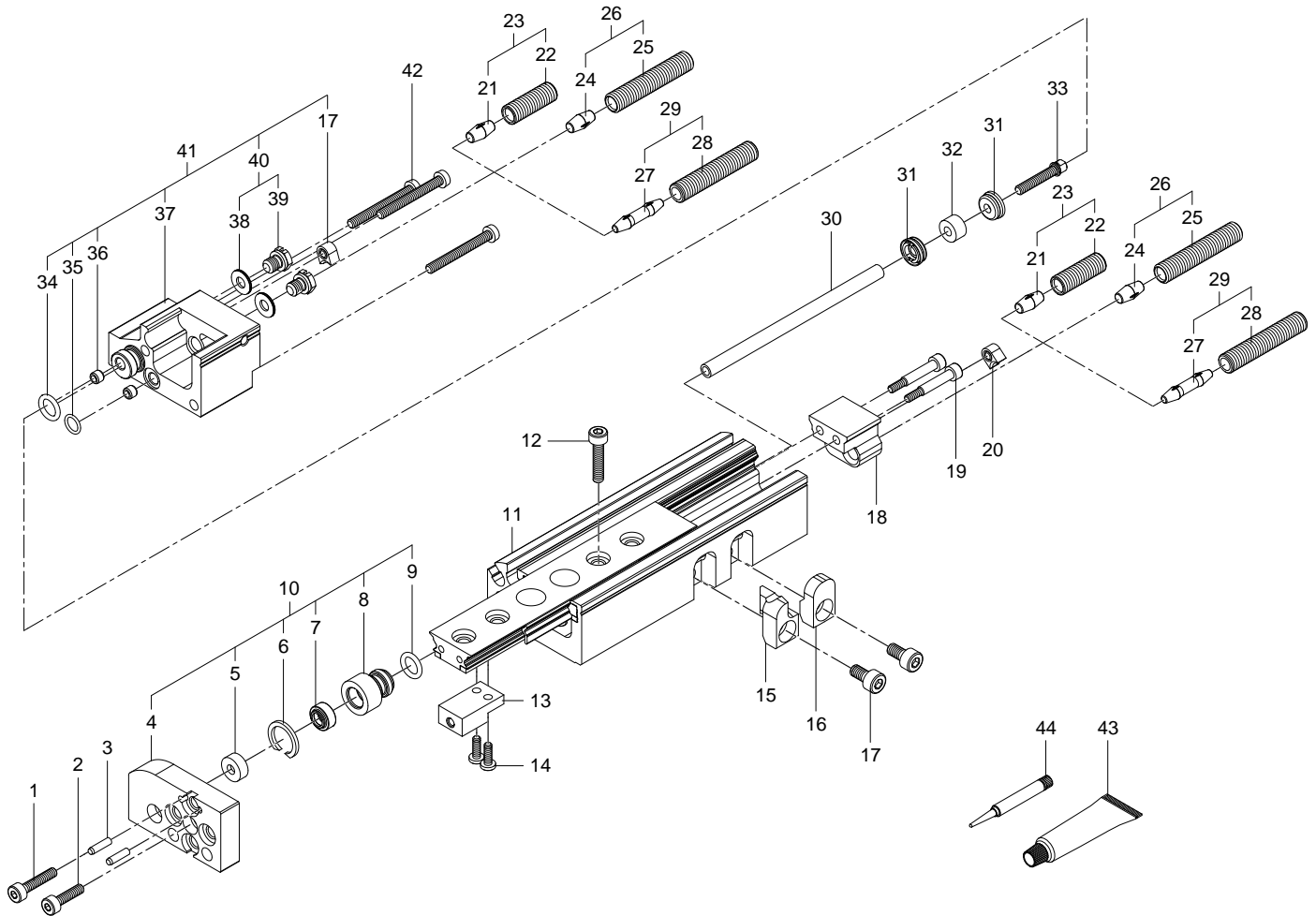

543910 DGSL-4-10-PA Mini slide - Series: All

Pos.	Part no.	Type	Note	Qty.	Unit
A	713743	DGSL-4-...- Set of wearing parts	Spare parts: 6, 7, 9, 12, 21, 24, 27, 31, 33, 34, 35, 38, 43, 44	1	PC
1	352345	ISO 4762-M2X10-12.9 Socket head screw	Tightening torque 0.37 Nm / 0.3 lbf ft Use locking compound. See position 44	1	PC
2	352344	ISO 4762-M2X8-12.9 Socket head screw	Tightening torque 0.37 Nm / 0.3 lbf ft	1	PC
3	328644	DIN 6325-1,5M6X6 Cylindrical pin		2	PC
4		DGSL-4 Yoke plate	Not available separately, see position 10 Glue with Loctite 401, adhesion surface area must free of oil and grease Warning! Disassembly requires recalibration.	1	PC
5		DGSL-4 Centring sleeve	Not available separately, see position 10 Glue with Loctite 401, adhesion surface area must free of oil and grease Warning! Disassembly requires recalibration.	1	PC
6		SB-8 Circlip	Not available separately, see position 10+999	1	PC
7		WIFC1-3X5,6X2,8-TPE-U Wiper seal	Not available separately, see position 10+999 Grease using during assembly. See position 43	1	PC
8		DGSL-4 Bearing cap	Not available separately, see position 10 Grease using during assembly. See position 43	1	PC
9		B-4X1-N-NBR75 O-ring ISO3601	Not available separately, see position 10+999 Grease using during assembly. See position 43	1	PC
10	8196910	DGSL-4 Set of components		1	PC
11		DGSL-4-10 Guide module	Not available	1	PC
12	207726	ISO 4762-M3X20-8.8 Socket head screw		1	PC
13	1248530	DGSL-4 Intermediate piece		1	PC
14	645503	M1,6X5 Screw	Tightening torque 0.17 Nm / 0.1 lbf ft Use locking compound. See position 44	2	PC
15	686782	DGSL-4 Stop		1	PC
16	686798	DGSL-4 Covering		1	PC
17		ISO 4762-M2,5X5-A2-70 Socket head screw	Not available Tightening torque 0.76 Nm / 0.6 lbf ft	1	PC
18	684369	DGSL-4 Moment compensator		1	PC
19	711552	DGSL-4 Shaft screw	Tightening torque 0.17 Nm / 0.1 lbf ft Use locking compound. See position 44	2	PC
20	699251	DGSL-4 Clamping component	Use locking compound. See position 44	2	PC
21	371073	2,6X3,7 Buffer element		1	PC
22		DYEF-S-M4-Y1 adjustment sleeve	Not available separately, see position 23	1	PC
23	1152500	DYEF-S-M4-Y1 Shock absorber	shock absorber -E	2	PC
24	371073	2,6X3,7 Buffer element		1	PC
25		DGSL-4-P adjustment sleeve	Not available separately, see position 26	1	PC

Pos.	Part no.	Type	Note	Qty.	Unit
26	1179810	DYEF-M4-Y1 Shock absorber	shock absorber -P	2	PC
27	683971	DGSL-4-PFJ Buffer		1	PC
28		DGSL-4-P1 adjustment sleeve	Not available separately, see position 29	1	PC
29	548370	DYEF-M4-Y1F Shock absorber		2	PC
30	711421	IRI-03-S0034.5-B Piston rod	Glue with Loctite 401, adhesion surface area must free of oil and grease Warning! Disassembly requires recalibration.	1	PC
31		DSA- 6-A Piston	Not available separately, see position A Grease using during assembly. See position 43	2	PC
32	367750	5X2,1X2,98 Ring magnet		1	PC
33	368654	M2X11 Shaft screw	Tightening torque 0.13 Nm / 0.1 lbf ft Use locking compound. See position 44	1	PC
34		B-4X1-N-NBR75 O-ring ISO3601	Not available separately, see position A Grease using during assembly. See position 43	1	PC
35		3,3X0,6-S-NBR75 O-ring	Not available separately, see position A Grease using during assembly. See position 43	1	PC
36		DGSL-4 Flow control plate	Not available separately, see position 41	2	PC
37		DGSL-4 Connection cap	Not available separately, see position 41	1	PC
38		OK-M3 Sealing ring	Not available separately, see position A	2	PC
39		B-M3-S9 Plug screw	Not available separately, see position 40 Tightening torque 0.5 Nm / 0.4 lbf ft	1	PC
40	712004	B-M3-S9-OK Blanking plug		2	PC
41	714227	DGSL- 4-...-ET Connection cover module		1	PC
42	734478	F-M2X18-A2-70 Raised head screw	Tightening torque 0.17 Nm / 0.1 lbf ft Use locking compound. See position 44	3	PC
43	684474	LUB-KC1 SILIKONFREI 20ML Lubricating grease		1	PC
44	8181256	CYBERBOND TM44 TB1ML Adhesive bonding agent		1	PC