



Brand of NTN Group

Technical data

UCP215

Bearing units



Grey cast housing, radial insert ball bearing with socket set screws, seal with slinger

KIT CONTENT

UC215G2, P215

VISUAL (S)

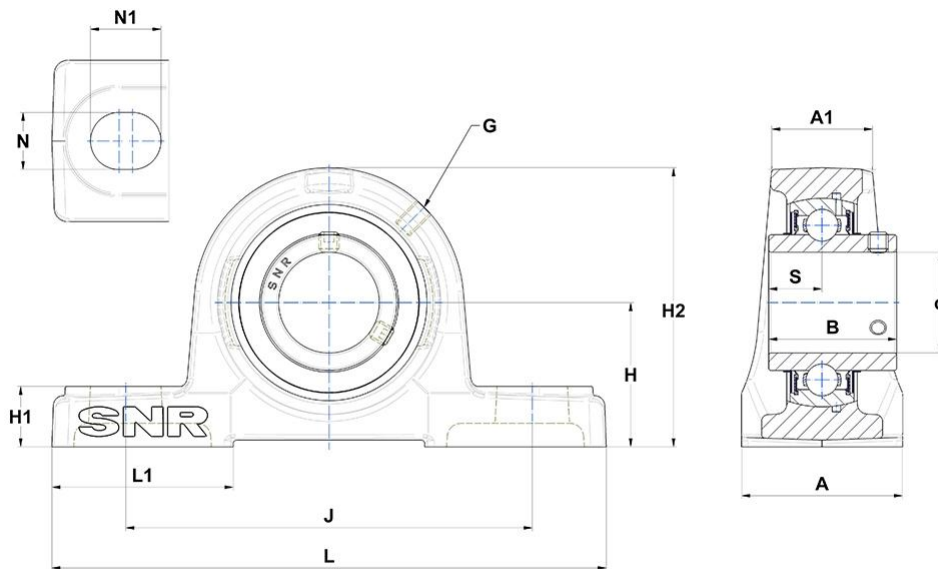

PRODUCT DEFINITION

Brand	SNR
A - Housing width	74 mm
A1 - Housing top width	48 mm
B - Width of Inner Ring	77,8 mm
d - Shaft diameter	75 mm
G - Grease fitting	M10x1



NTN Europe

1 rue des Usines · BP 2017 · 74010 Annecy Cedex · France · Tel. +33 (0)4 50 65 30 00
S.A. au capital de 322 639 919 € · RCS ANNECY B 325 821 072 · Id. Fiscale : FR 48 325 821 072
SIRET 325 821 072 00015 · Code APE 2815 Z · Code NACE 28.15

PRODUCT DEFINITION

H - Distance mounting base to centerline spheric. seating diam.	82,6 mm
H1 - Housing foot height	28 mm
H2 - Housing height	163 mm
J - Mounting holes distance	217 mm
L - Housing length	275 mm
L1 - Housing foot length	85 mm
N - Mounting hole dimension	25 mm
N1 - Mounting hole length	31 mm
S - Distance front side/bearing centre	33,3 mm

PRODUCT PERFORMANCE

C - Dynamic load rating	66000000 mN
C0 - Static load rating	49500000 mN
Operating temperature min.	253,15 °K
Operating temperature max.	373,15 °K

OTHER FEATURES

Mass	7,31 kg
Recommended tightening torque for set screw	33 N-m

