

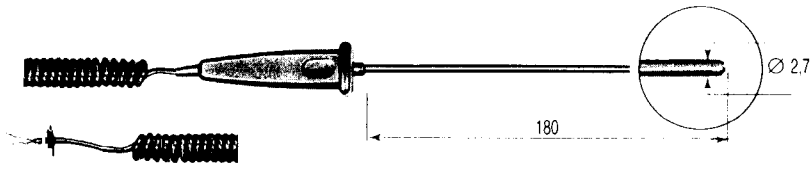









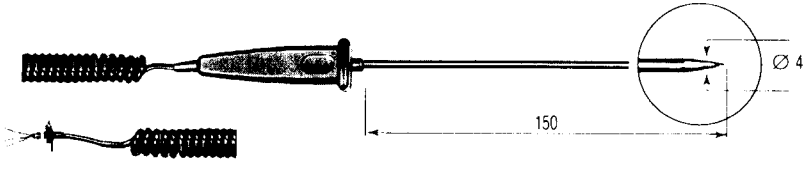
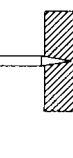

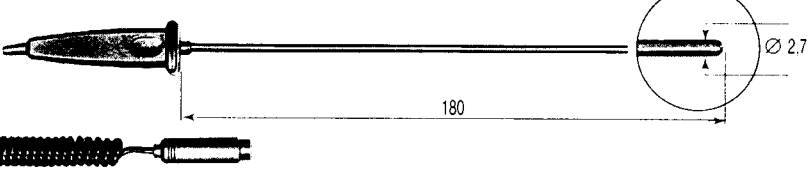
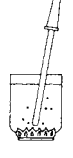

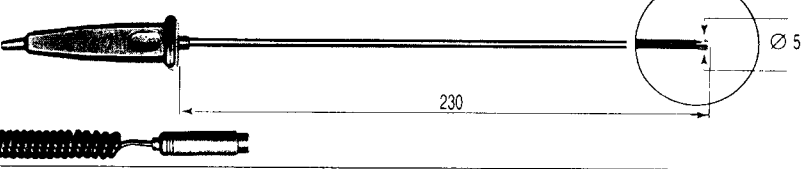
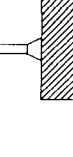

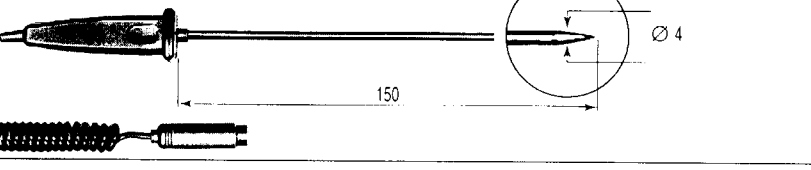

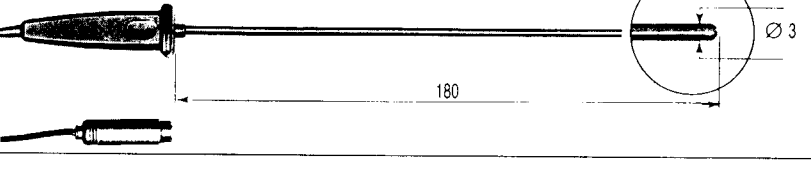

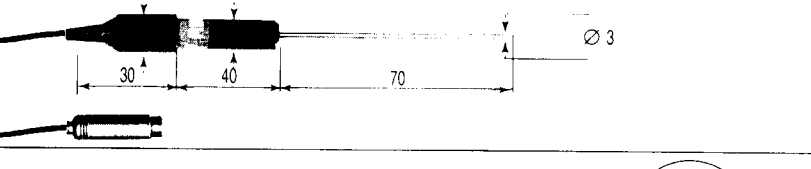
SONDE SENSORE Pt 100 - Pt 100 SENSOR PROBES - SONDES CAPTEUR Pt 100 - FÜLER MIT Pt 100 SENSOR - SONDAS Pt 100

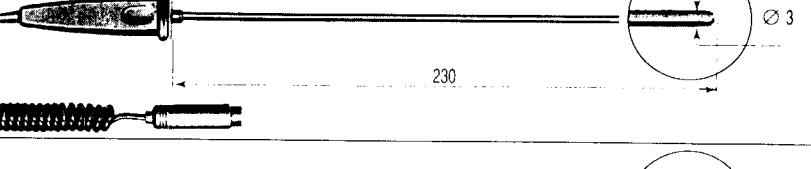
COD.	°C max.	τ <sup>**</sup> sec.	DIMENSIONI	DIMENSIONS	DIMENSIONS	ABMESSUNGEN	DIMENSIONES	IMPIEGO USE UTILISATION GEBRAUCH EMPLOO	
S 8601P	-50 +200	3.5"							
S 8601PP	-50 +200	5"							
STS3	-50 +200	3.5"							
STS3/C	-50 +200	5"							
STS3/P	-50 +200	5"							
STS4	-50 +200	3"							
STS871	-50 +200	3"							
STS5	-60 +400	3"							
STS5/500	-60 +400	10"							
STS5/1000	-60 +400	10"							

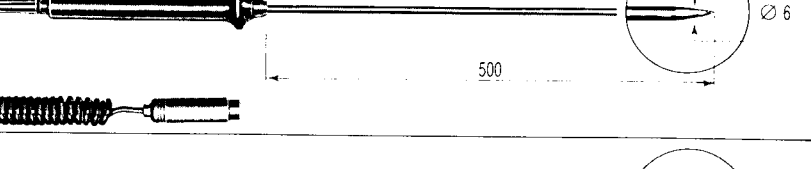
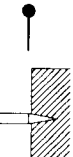

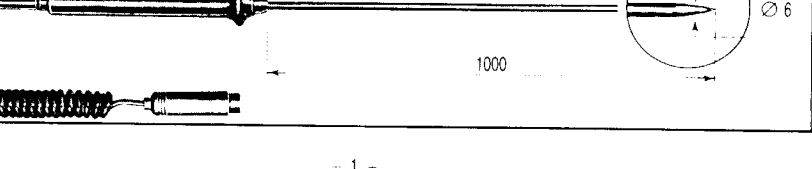
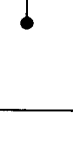







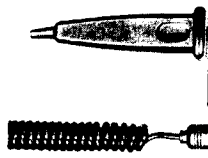
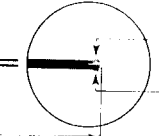
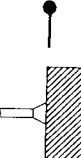



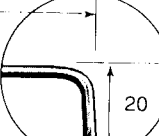



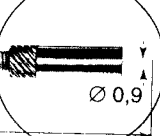



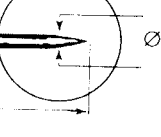



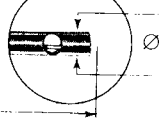



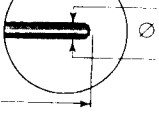



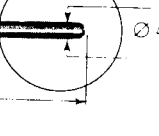

HD 8601P

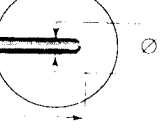
HD 8264  
HD 8501



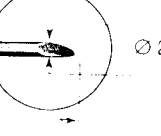



HD 8602

HD 8605

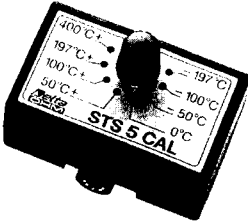
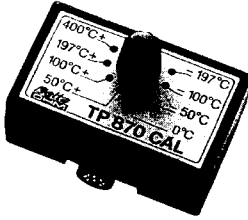
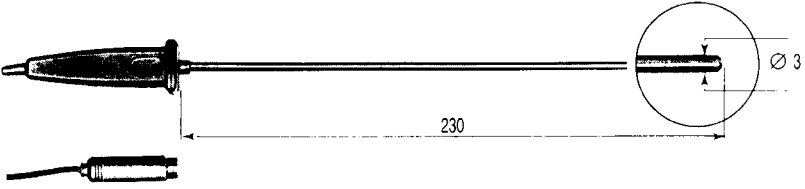
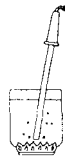
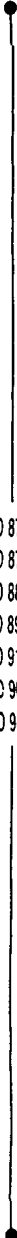
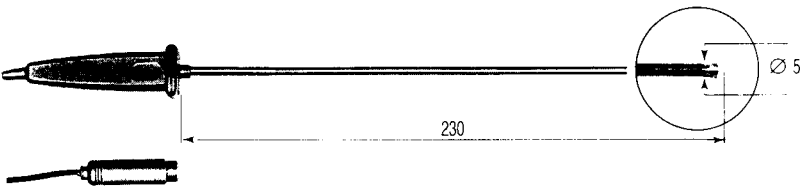
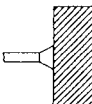
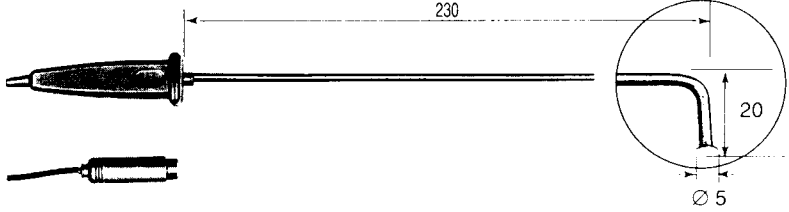

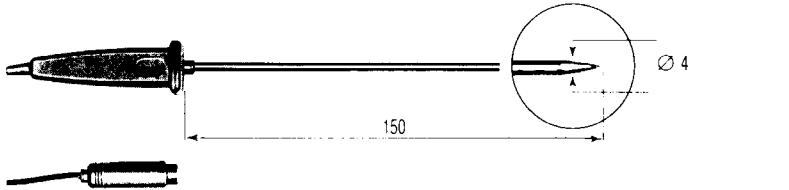
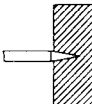
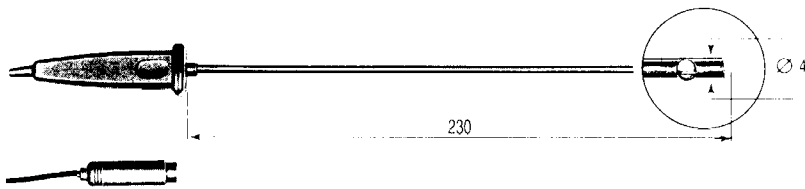

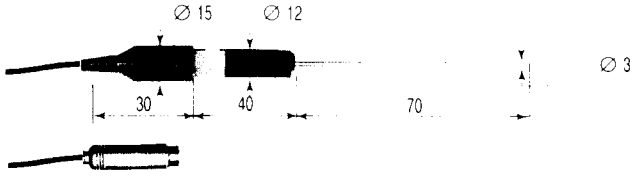







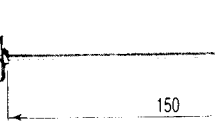



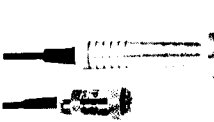
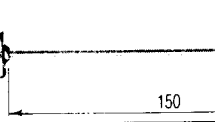

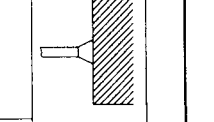
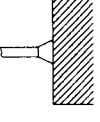

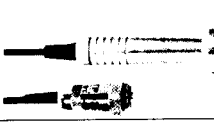
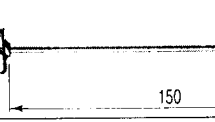

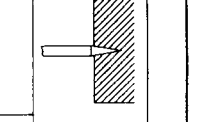
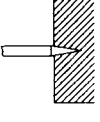

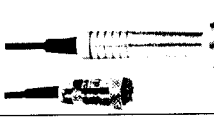
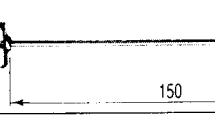
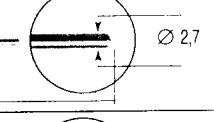
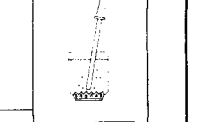
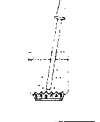

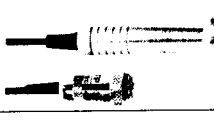
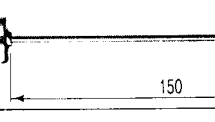

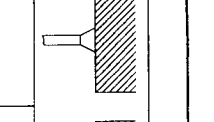
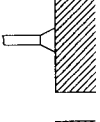

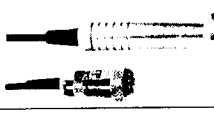
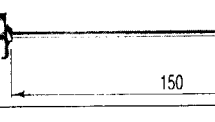

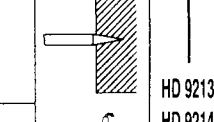
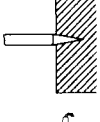

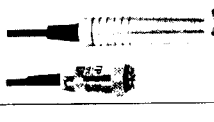
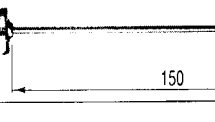
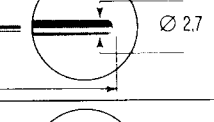
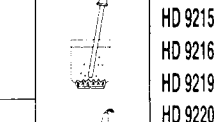
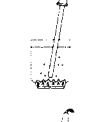

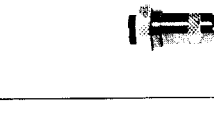
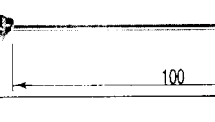

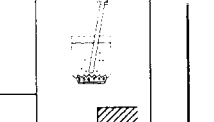
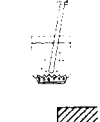

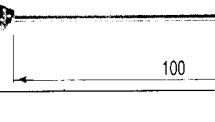

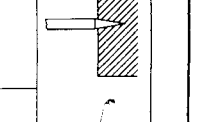
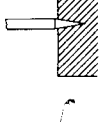

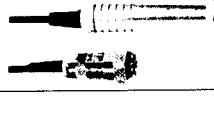
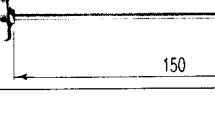
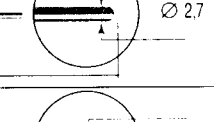
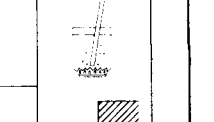
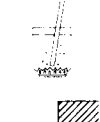

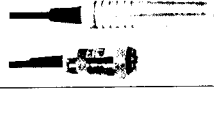
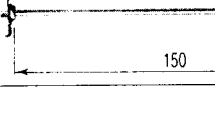
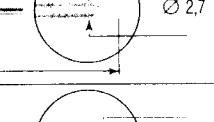
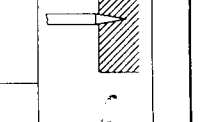
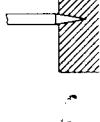

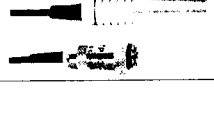
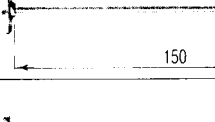
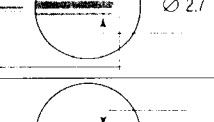
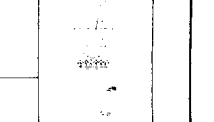

SONDE SENSORE Pt 100 - Pt 100 SENSOR PROBES - SONDES CAPTEUR Pt 100 - FÜLER MIT Pt 100 SENSOR - SONDAS Pt 100

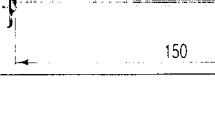
COD.	C max.	± sec.	DIMENSIONI	DIMENSIONS	DIMENSIONS	ABMESSUNGEN	DIMENSIONES	IMPIEGO USE UTILISATION GEBRAUCH EMPLEO	
STS5C	-60 +400	5"		230		Ø 5			
STS5CC	-60 +400	5"		230		Ø 5			
STS5I	-60 +250	1"		230		Ø 0,9			
STS5P	-60 +400	5"		150		Ø 4			
STS5A	-60 +300	10"		230		Ø 4			HD 8605
STS6	-200 +200	3"		230		Ø 3			
STS7	-60 +600	6"		230		Ø 4			
STS8	-60 +250	2"		80		Ø 2			
STS9	-60 +250	3"		80		Ø 2			

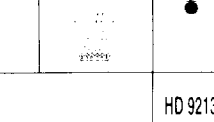
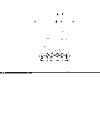











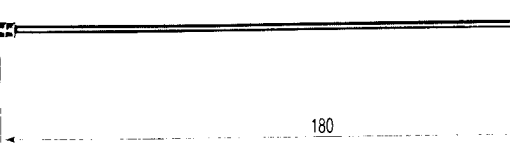

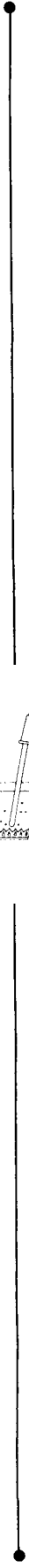

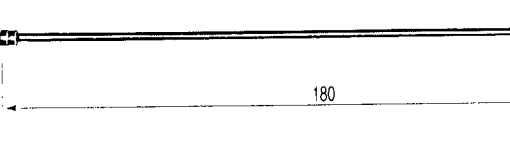
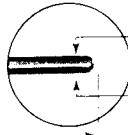
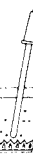

SONDE SENSORE Pt 100 - Pt 100 SENSOR PROBES - SONDES CAPTEUR Pt 100 - FÜLER MIT Pt 100 SENSOR - SONDAS Pt 100

COD.	C max.	t <sup>**</sup> sec.	DIMENSIONI	DIMENSIONS	DIMENSIONS	ABMESSUNGEN	DIMENSIONES	IMPIEGO USE UTILISATION GEBRAUCH EMPLEO	
STS 5 CAL TEST	Simula 8 valori fissi di una sonda Pt100 da -197°C a +400°C.							HD 8605	
TP 870 CAL TEST	Simula 8 valori fissi di una sonda TP870 da -197°C a +400°C.							HD 9117 HD 8705 HD 8706 HD 8804 HD 8901 HD 9021 DO 9406	
TP 870	-60 +400	3"							
TP 870C	-60 +400	5"							
TP 870CC	-60 +400	5"							
TP 870P	-60 +400	3"							
TP 870A	-60 +300	12"							
TP 871	-60 +200	3"							

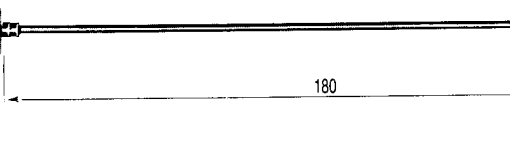
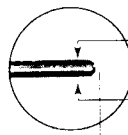
SONDE SENSORE Pt 100 - Pt 100 SENSOR PROBES - SONDES CAPTEUR Pt 100 - FÜLER MIT Pt 100 SENSOR - SONDAS Pt 100

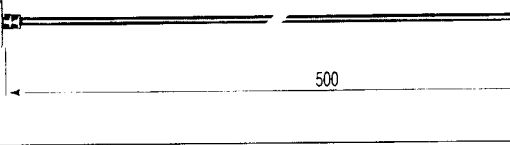
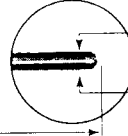
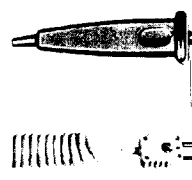
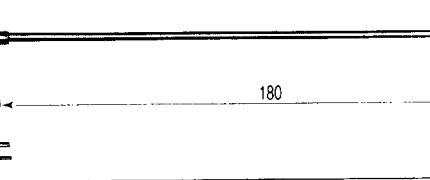
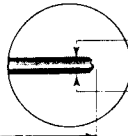
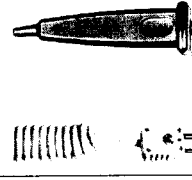
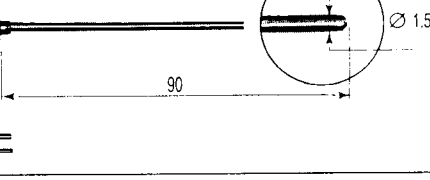
COD.	C max.	T <sup>**</sup> sec.	IEC 751/1983 BS 1904/1984 DIN 43760/1980	DIMENSIONI	DIMENSIONS	DIMENSIONS	ABMESSUNGEN	DIMENSIONES	IMPIEGO USE UTILISATION GEBRAUCH EMPLEO		
TP 9A	-70°C +400°C	3.5"	CLASS A					Ø 2.7			
TP 9AC	-70°C +400°C	5.5"	CLASS A					Ø 4			
TP 9AP	-70°C +400°C	4"	CLASS A					Ø 2.7			
TP 93	-70°C +400°C	3.5"	CLASS 1/3 DIN					Ø 2.7			
TP 93C	-70°C +400°C	5.5"	CLASS 1/3 DIN					Ø 4			
TP 93P	-70°C +400°C	4"	CLASS 1/3 DIN					Ø 2.7			
TP 936	-200°C +600°C	3.5"	CLASS 1/3 DIN					Ø 2.7			
TP 932	-70°C +200°C	3.5"	CLASS 1/3 DIN					Ø 2.7			
TP 932P	-70°C +200°C	4"	CLASS 1/3 DIN					Ø 2.7			
TP 95	-70°C +400°C	3.5"	CLASS 1/5 DIN					Ø 2.7			
TP 95P	-70°C +400°C	4"	CLASS 1/5 DIN					Ø 2.7			
TP 956	-200°C +600°C	3.5"	CLASS 1/5 DIN					Ø 2.7			
TP 910	200°C +550°C	3.5"	CLASS 1/10 DIN					Ø 2.7			
TP 9 CAL TEST	Simula 8 valori fissi di un sensore PT100 da -50°C a +197°C.										HD 9213 HD 9215 HD 9216
TP 10 CAL TEST	Simula 8 valori fissi di un sensore PT100 da -197 C a +400 C.										HD 9214 HD 9219 HD 9220

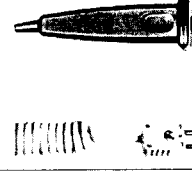
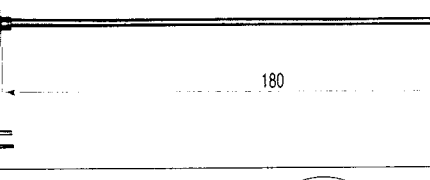
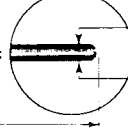
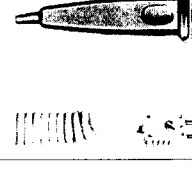
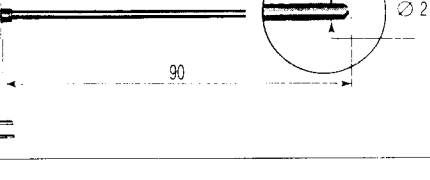

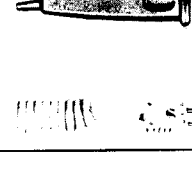
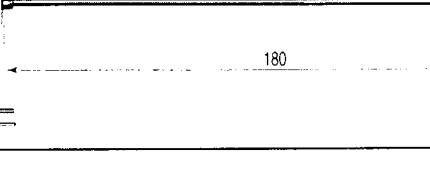
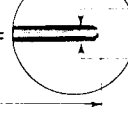







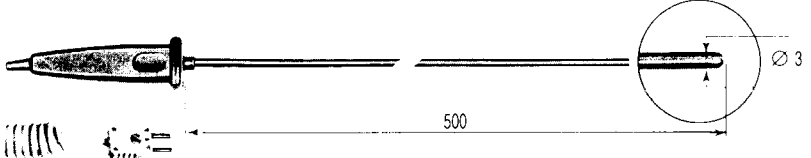
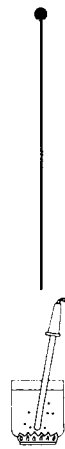

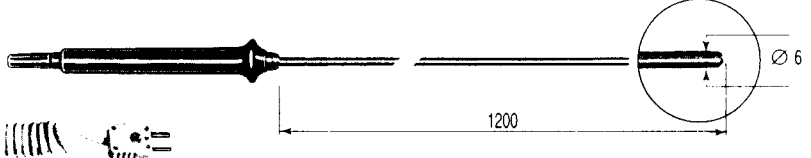
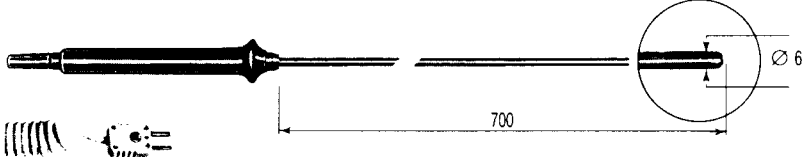
SONDE SENSORE TERMOCOPPIA TIPO "K" (CHROMEL-ALUMEL) - THERMOCOUPLE K TYPE PROBES (CHROMEL-ALUMEL)  
 SONDES A THERMOCOUPLE TYPE K (CHROMEL-ALUMEL) - THERMOPAAFÜHLER TYP K (CHROMEL-ALUMEL) - SONDAS TERMOPARES TIPO K (CHROMEL-ALUMEL)

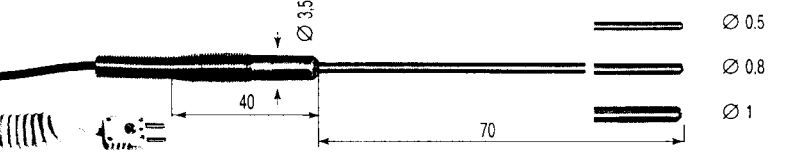
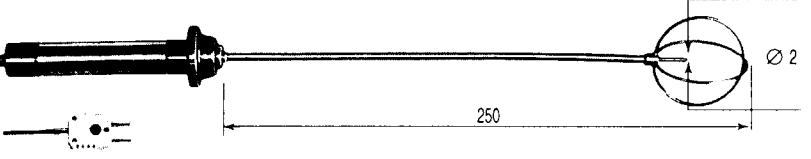
COD.	C max.	sec.	DIMENSIONI	DIMENSIONS	DIMENSIONS	ABMESSUNGEN	DIMENSIONES	IMPIEGO USE UTILISATION GEBRAUCH EMPLEO	
TP 641/05	600	1"			180		∅ 0.5		
TP 641/08	600	1"					∅ 0.8		
TP 641/10	600	1"					∅ 1		
TP 641	800	2"					∅ 1.5		
TP 642	800	2"			180		∅ 2		
TP 643	800	3"			180		∅ 3		
TP 650	800	3"			500		∅ 3		
TP 741	800	2"			180		∅ 1.5		
TP 741/1	800	2"			90		∅ 1.5		
TP 742	800	2"			180		∅ 2		
TP 742/2	400	2"			90		∅ 2		
TP 743	800	3"			180		∅ 3		

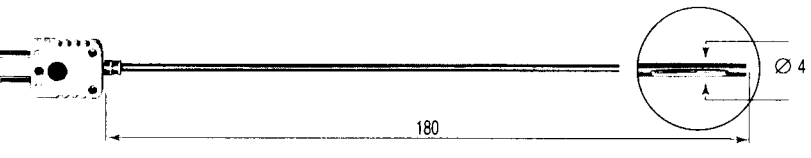
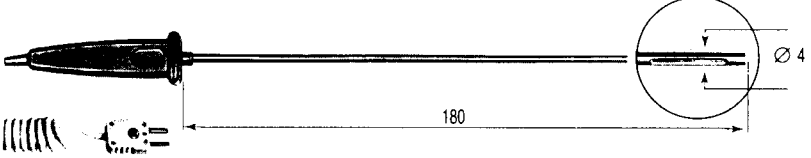

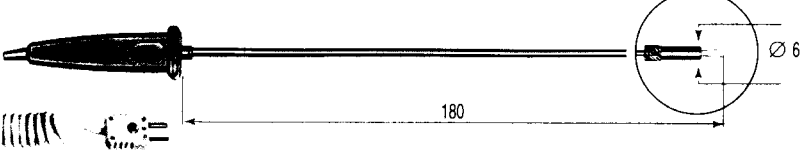
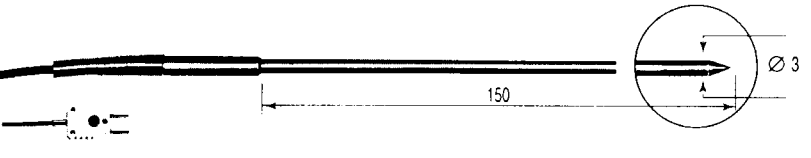

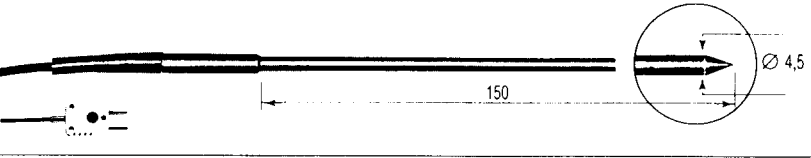
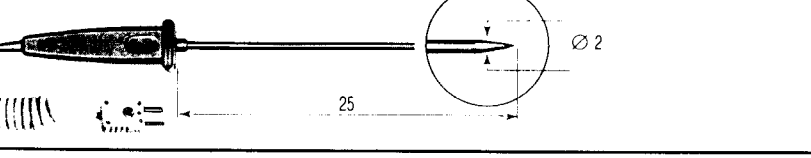
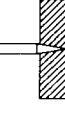





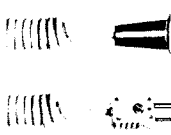
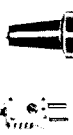
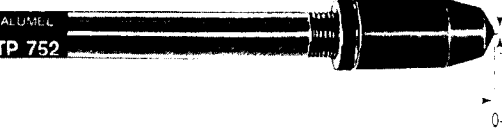
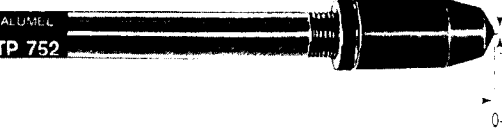
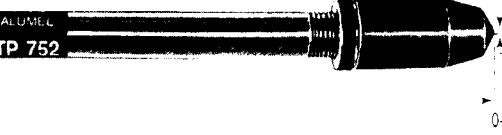

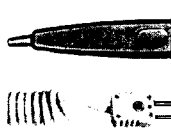

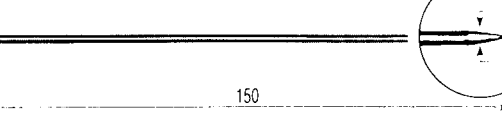
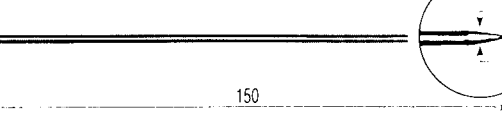
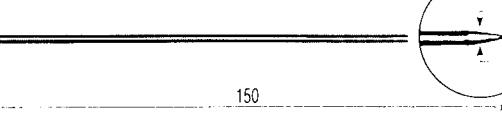
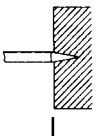
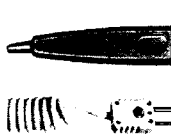

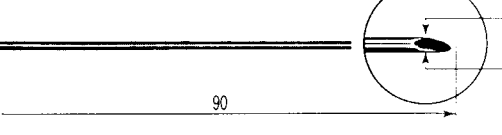
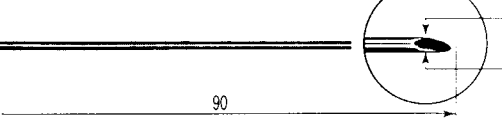
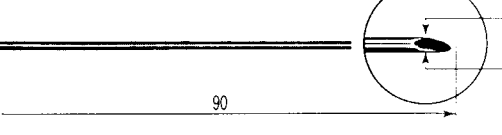



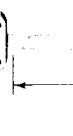
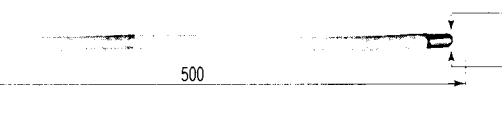
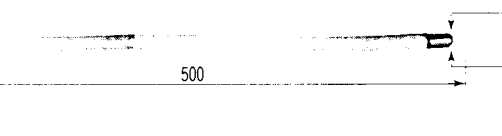
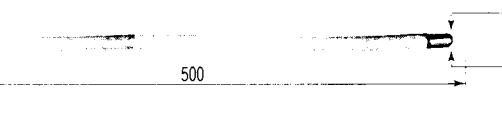

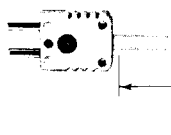
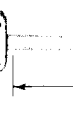
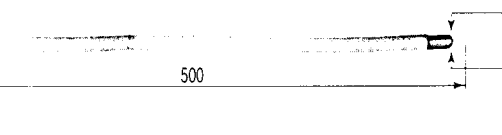
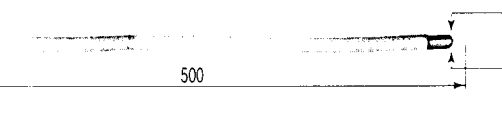
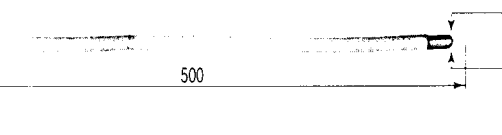

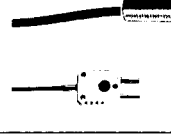
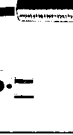
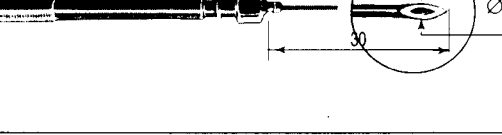
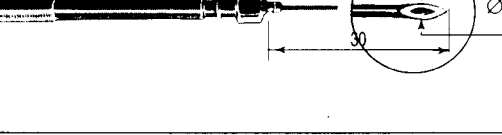
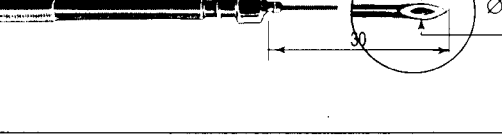

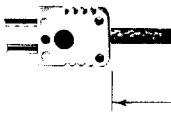
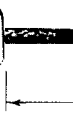
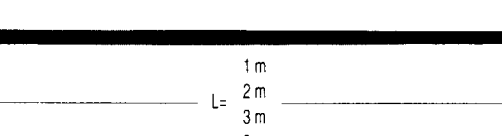
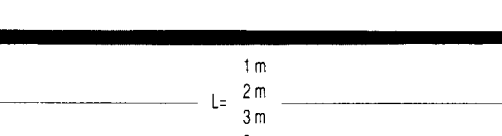
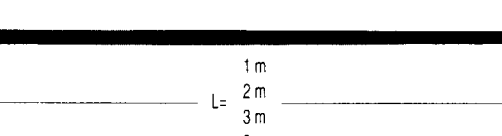





HD 8464  
 HD6464SB  
 HD 9218

HD 8802  
 HD 8704  
 HD 9016  
 HD 9116  
 HD 9218

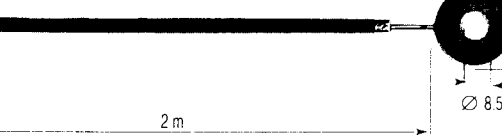
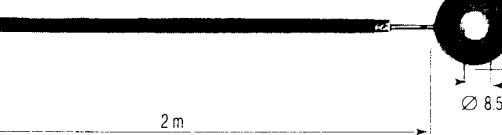
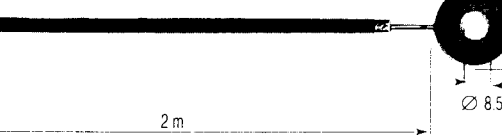

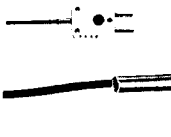

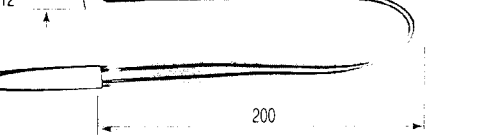
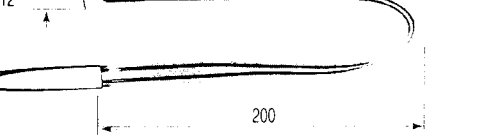
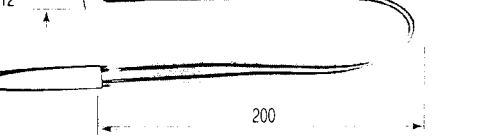





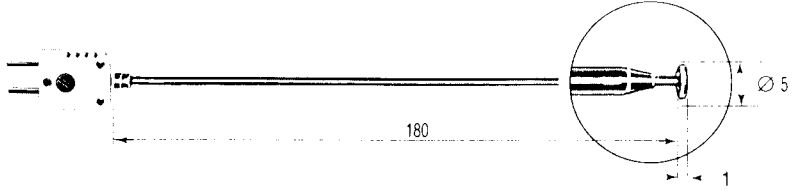

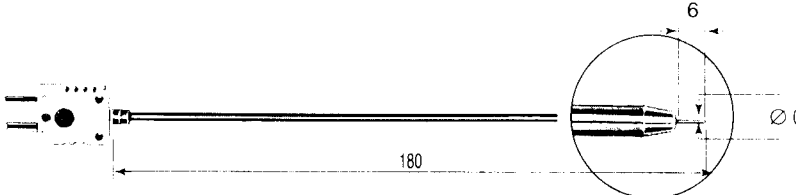

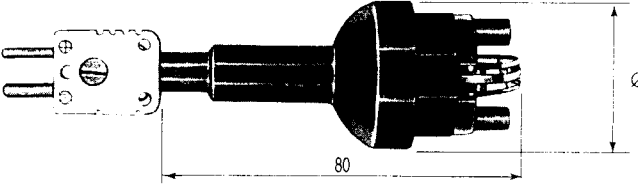
SONDE SENSORE TERMOCOPPIA TIPO "K" (CHROMEL-ALUMEL) - THERMOCOUPLE K TYPE PROBES (CHROMEL-ALUMEL)  
 SONDES A THERMOCOUPLE TYPE K (CHROMEL-ALUMEL) - THERMOPAARFÜHLER TYP K (CHROMEL-ALUMEL) - SONDAS TERMOPARES TIPO K (CHROMEL-ALUMEL)

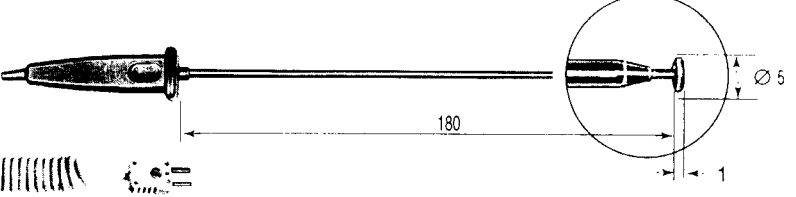
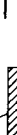
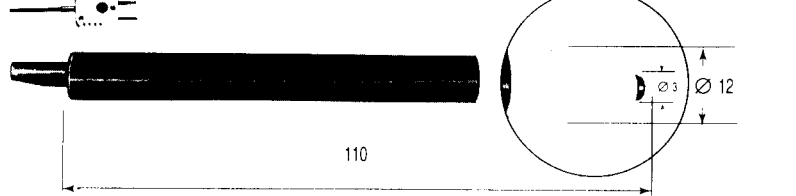
COD.	C max.	sec.	DIMENSIONI	DIMENSIONS	DIMENSIONS	ABMESSUNGEN	DIMENSIONES	IMPIEGO USE UTILISATION GEBRAUCH EMPLEO	
TP 750	800	3"							
TP 651	1200	6"							
TP 652	1200	6"							HD 8802 HD 8704 HD 9016 HD 9116 HD 9218
TP 656/05	400	1"							
TP 656/08	400	1"							
TP 656	600	1"							
TP 760	260	3"							
TP 644	400	4"							
TP 744	400	4"							HD 8802 HD 8704 HD 9016 HD 9116 HD 9218
TP 771	400	1"							
TP 659	500	3"							HD 8464 HD 8802 HD 8704 HD 9016 HD 9116 HD 9218
TP 660	500	4"							
TP 751	300	2"							

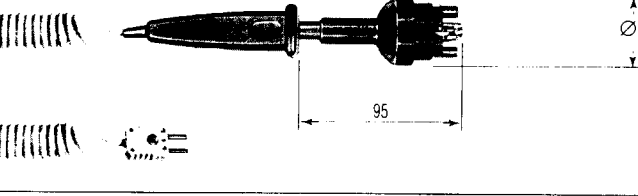
SONDE SENSORE TERMOCOPPIA TIPO "K" (CHROMEL-ALUMEL) - THERMOCOUPLE K TYPE PROBES (CHROMEL-ALUMEL)  
 SONDES A THERMOCOUPLE TYPE K (CHROMEL-ALUMEL) - THERMOPAAUFÜHLER TYP K (CHROMEL-ALUMEL) - SONDAS TERMOPARES TIPO K (CHROMEL-ALUMEL)

COD.	°C max.	T <sup>**</sup> sec.	DIMENSIONI	DIMENSIONS	DIMENSIONS	ABMESSUNGEN	DIMENSIONES	IMPIEGO USE UTILISATION GEBRAUCH EMPLEO	
TP 752	250	1"							
TP 758	400	4"							HD8802 HD8704 HD9016 HD 9116 HD 9218
TP 776	400	2"							
TP 657	200	3"							
TP 657/1	200	5"							HD 8464 HD 8802 HD 8704 HD 9016 HD 9116 HD 9218
TP 658	200	2"							
TP 647 TP 647/2 TP 647/3 TP 647/5	400 400 400 400	2" 2" 2" 2"							
TP 653	400	5"							HD8464 HD8464SB HD8802 HD8704 HD 9016 HD 9116 HD 9218
TP 654	400	5"							
TP 759	150	2"							HD 8464 HD 8802 HD 8704 HD 9016 HD 9116 HD 9218

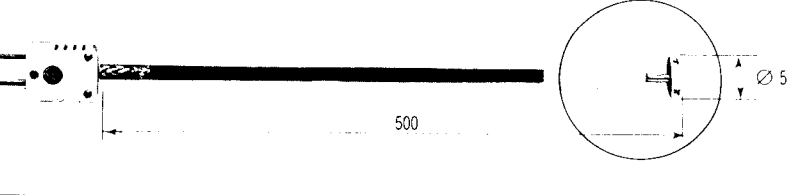
SONDE SENSORE TERMOCOPPIA TIPO "K" (CHROMEL-ALUMEL) - THERMOCOUPLE K TYPE PROBES (CHROMEL-ALUMEL)  
 SONDES A THERMOCOUPLE TYPE K (CHROMEL-ALUMEL) - THERMOPAAUFÜHLER TYP K (CHROMEL-ALUMEL) - SONDAS TERMOPARES TIPO K (CHROMEL-ALUMEL)





COD.	C max.	sec.	DIMENSIONI	DIMENSIONS	DIMENSIONS	ABMESSUNGEN	DIMENSIONES	IMPIEGO USE UTILISATION GEBRAUCH EMPLEO	
TP 645	500	3"							
TP 646	400	0.5"							
TP 648	200	2"							
TP 745	500	3"							
TP 746	250	2"							
TP 748	200	2"							
TP 749	200	2"							
TP 772	400	3"							

HD 8464  
HD6464SB

HD 8802  
HD 8704  
HD 9016  
HD 9116  
HD 9218

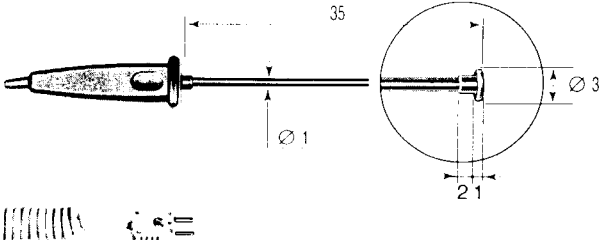

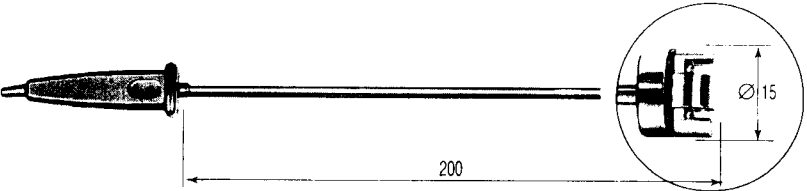
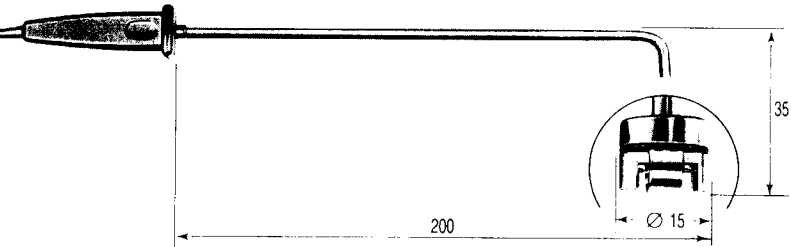
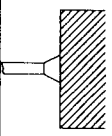
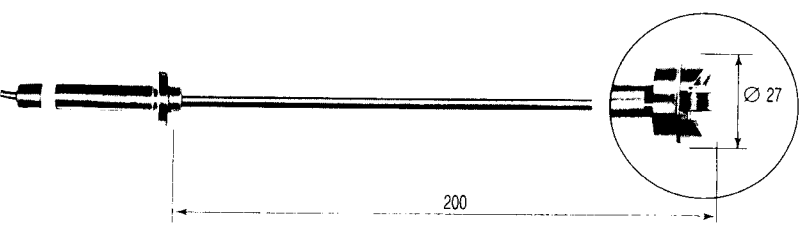
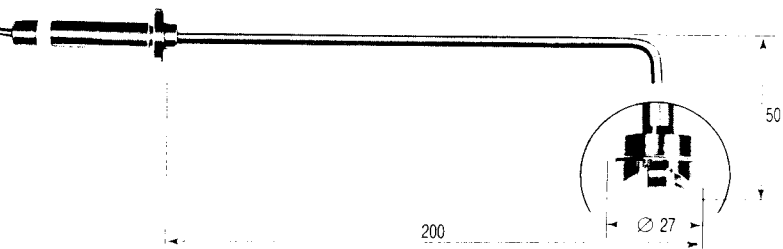
SONDE SENSORE TERMOCOPPIA TIPO "K" (CHROMEL-ALUMEL) - THERMOCOUPLE K TYPE PROBES (CHROMEL-ALUMEL)  
 SONDES A THERMOCOUPLE TYPE K (CHROMEL-ALUMEL) - THERMOAARFÜHLER TYP K (CHROMEL-ALUMEL) - SONDAS TERMOPARES TIPO K (CHROMEL-ALUMEL)

COD.	C max.	sec.	DIMENSIONI	DIMENSIONS	DIMENSIONS	ABMESSUNGEN	DIMENSIONES	IMPIEGO USE UTILISATION GEBRAUCH EMPLEO	
TP 777	400	3"							
TP 754	500	2"							
TP 754/9	500	2"							HD 8802 HD 8704 HD 9016 HD 9116 HD 9218
TP 755/0	800	2"							
TP 755/09	800	2"							



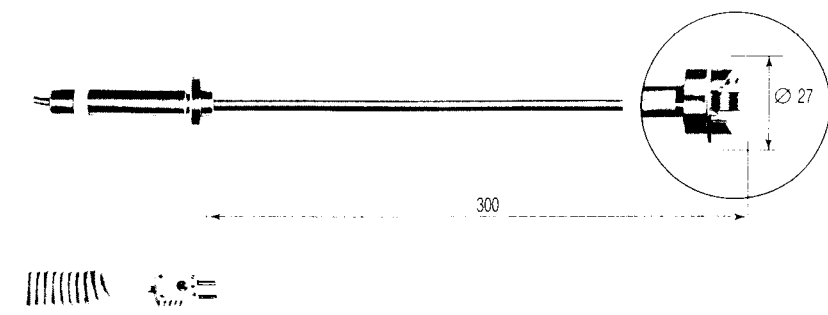
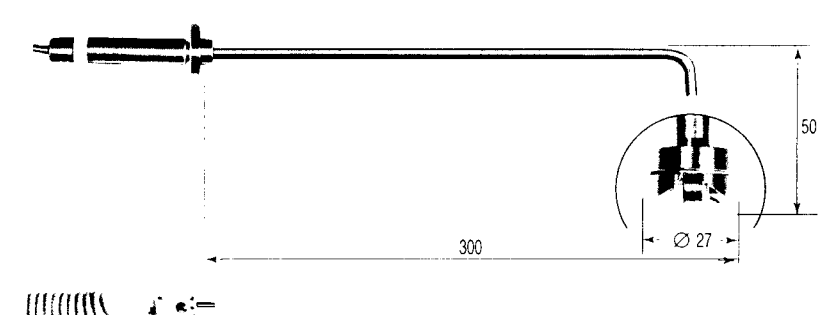
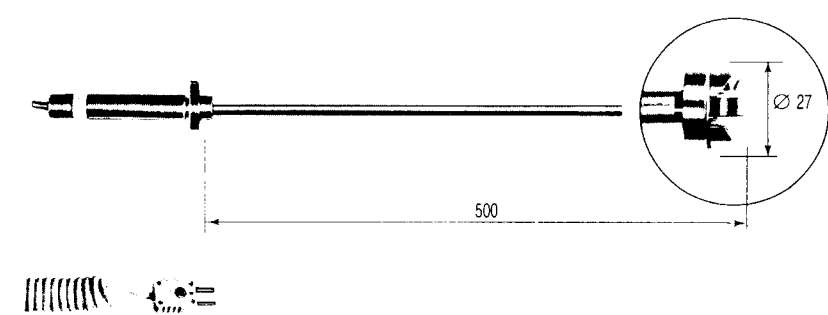
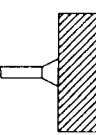
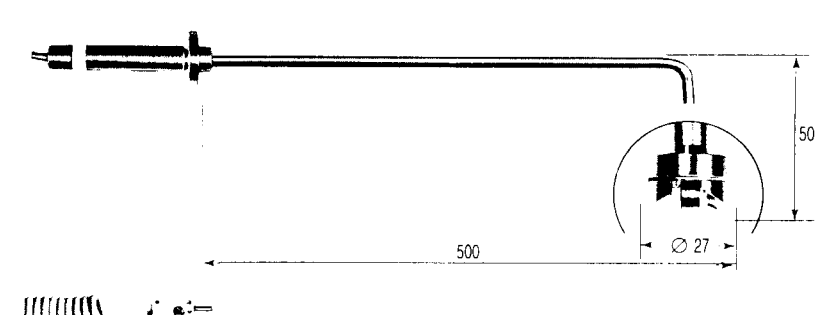
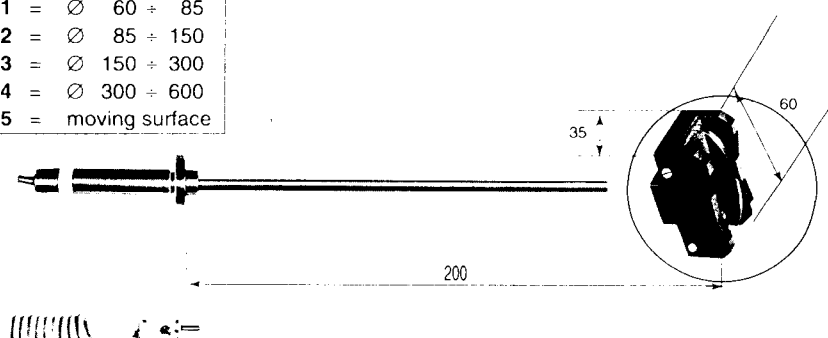

SONDE SENSORE TERMOCOPPIA TIPO "K" (CHROMEL-ALUMEL) - THERMOCOUPLE K TYPE PROBES (CHROMEL-ALUMEL)  
 SONDES A THERMOCOUPLE TYPE K (CHROMEL-ALUMEL) - THERMOPAAUFÜHLER TYP K (CHROMEL-ALUMEL) - SONDAS TERMOPARES TIPO K (CHROMEL-ALUMEL)

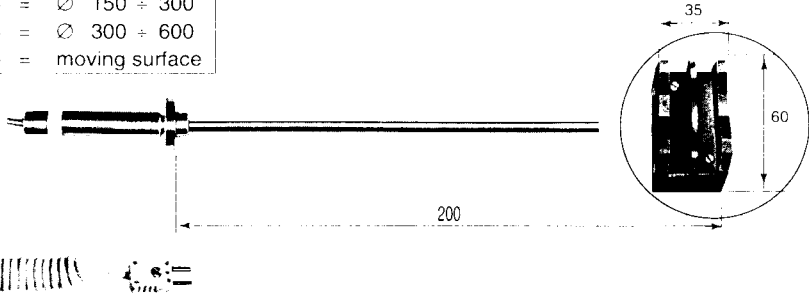
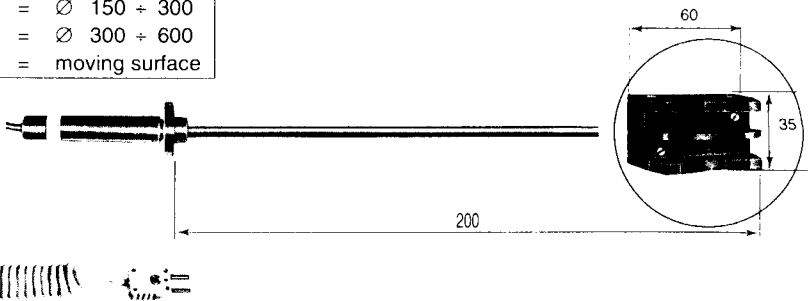
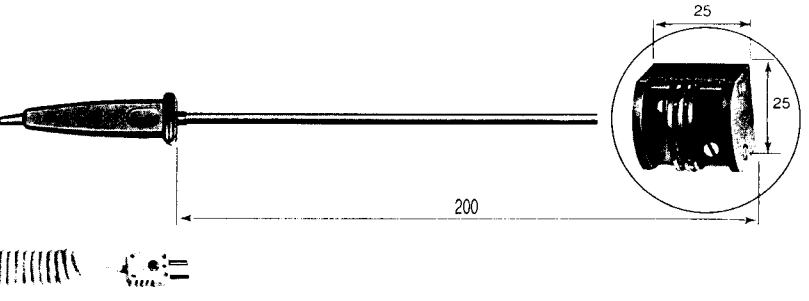
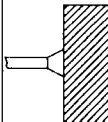
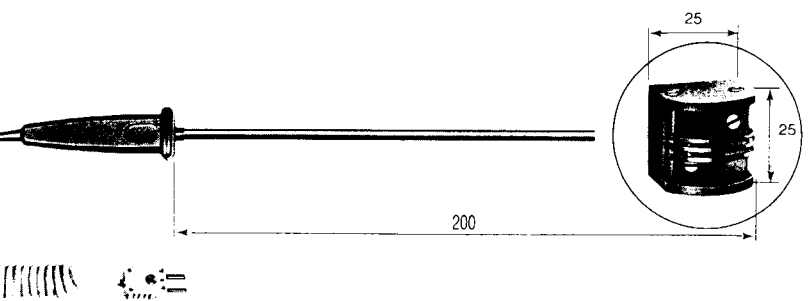
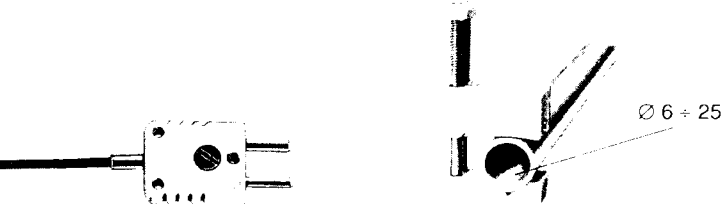
COD.	°C max.	τ sec.	DIMENSIONI	DIMENSIONS	DIMENSIONS	ABMESSUNGEN	DIMENSIONES	IMPIEGO USE UTILISATION GEBRAUCH EMPLOO	
TP 755	800	2"							
TP 755/9	800	2"							
TP 755/1	800	2"							HD 8802 HD 8704 HD 9016 HD 9116 HD 9218
TP 755/19	800	2"							
TP 774	250	2"	<div data-bbox="406 1803 638 1937" style="border: 1px solid black; padding: 5px; width: fit-content;">                     1 = Ø 60 ÷ 85                      2 = Ø 85 ÷ 150                      3 = Ø 150 ÷ 300                      4 = Ø 300 ÷ 600                      5 = moving surface                 </div> 						

SONDE SENSORE TERMOCOPIA TIPO "K" (CHROMEL-ALUMEL) - THERMOCOUPLE K TYPE PROBES (CHROMEL-ALUMEL)  
 SONDES A THERMOCOUPLE TYPE K (CHROMEL-ALUMEL) - THERMOPAARFÜHLER TYP K (CHROMEL-ALUMEL) - SONDAS TERMOPARES TIPO K (CHROMEL-ALUMEL)

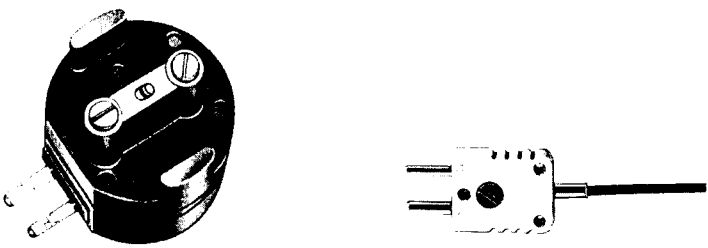
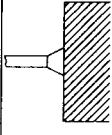
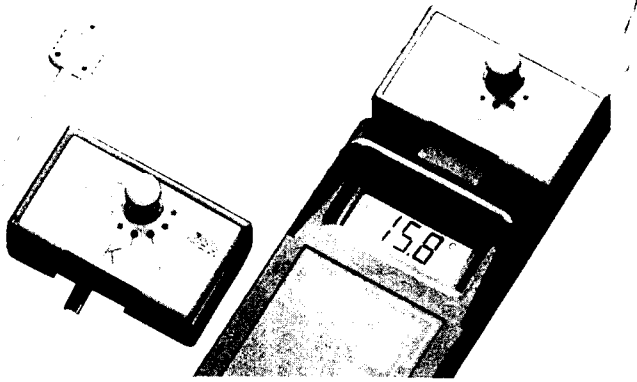
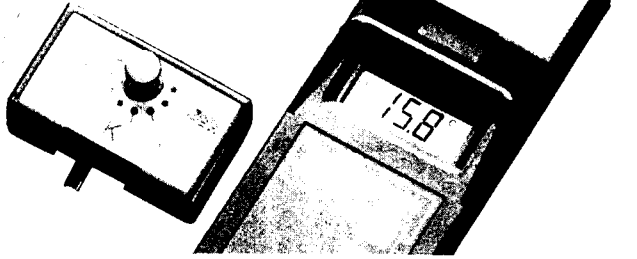
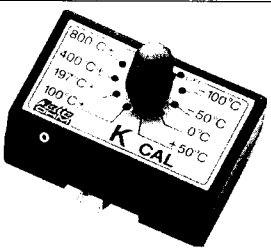
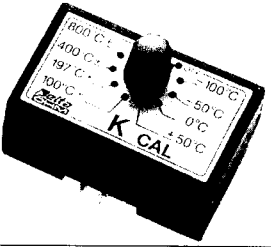
COD.	C max.	sec.	DIMENSIONI	DIMENSIONS	DIMENSIONS	ABMESSUNGEN	DIMENSIONES	IMPIEGO USE UTILISATION GEBRAUCH EMPLEO	
TP 774/1	250	2"	<p>1 = <math>\varnothing</math> 60 <math>\pm</math> 85                      2 = <math>\varnothing</math> 85 <math>\pm</math> 150                      3 = <math>\varnothing</math> 150 <math>\pm</math> 300                      4 = <math>\varnothing</math> 300 <math>\pm</math> 600                      5 = moving surface</p>						
TP 774/2	250	2"	<p>1 = <math>\varnothing</math> 60 <math>\pm</math> 85                      2 = <math>\varnothing</math> 85 <math>\pm</math> 150                      3 = <math>\varnothing</math> 150 <math>\pm</math> 300                      4 = <math>\varnothing</math> 300 <math>\pm</math> 600                      5 = moving surface</p>						
TP 775	600	2"							HD 8802 HD 8704 HD 9016 HD 9116 HD 9218
TP 775/1	600	2"							
TP 655	180	2"							

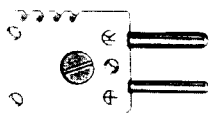
**SONDE SENSORE TERMOCOPPIA TIPO "K" (CHROMEL-ALUMEL) - THERMOCOUPLE K TYPE PROBES (CHROMEL-ALUMEL)  
 SONDES A THERMOCOUPLE TYPE K (CHROMEL-ALUMEL) - THERMOPAAUFÜHLER TYP K (CHROMEL-ALUMEL) - SONDAS TERMOPARES TIPO K (CHROMEL-ALUMEL)**

COD.	°C max.	t** sec.	DIMENSIONI	DIMENSIONS	DIMENSIONS	ABMESSUNGEN	DIMENSIONES	IMPIEGO USE UTILISATION GEBRAUCH EMPLEO		
TP 757	450	2"							HD 8802 HD 8704 HD 9016 HD 9116 HD 9218	
TP 908									HD 8605	
TP 909									HD 8802 HD 8704 HD 9016 HD 9116 HD 9218	
KCAL TEST			<p>Simula 8 valori fissi della scala della termocoppia K da -100°C a +800°C. Completo di batteria al litio. Indicato per gli strumenti con ingresso a termocoppia K, connettore mignon.</p>						HD 8464 HD8464SB HD 8802	
									HD 8704 HD 9016 HD 9116 HD 9218	
CM	"K"									
CS	"K"									
PW	"K"									
<p>Costante di tempo per rispondere al 63% della variazione di temperatura finale                  tempi di risposta sono riferiti: Per le sonde ad immersione in acqua a 100°C                  Per le sonde a contatto al contatto di una superficie metallica a 200°C                  Per le sonde in aria alla temperatura dell'aria a 100°C</p> <p>Time constant at 63% of final temperature variation                  Response time is referred: For immersion probes at 100°C                  For surface probes with metallic surface at 200°C                  For air probe at air temperature of 100°C</p> <p>Constante du temps au 63% de la variation de la température finale                  Le temps de réponse: Pour sonde à immersion à 100°C                  Pour sondes à surface avec une surface métallique à 200°C                  Sondes pour l'air à une température de l'air de 100°C</p> <p>Zeitkonstante von 63% des Temperaturemsprungs                  Anspechzeit: Für Eintauchfühler 100°C                  Für Kontakfühler beim Kontakt mit metallischen Oberflächen bei 200°C                  Für Luftfühler bei 100°C Lufttemperatur</p>			<p>Constante de tiempo al 63% de la variación de la temperatura final                  Tiempo de respuesta: Para sondas de inmersión a 100°C                  Para sondas de superficie con superficie metálica a 200°C                  Para sondas de aire a una temperatura del aire de 100°C</p> <p>A temperature sopra i 400°C evitare urti violenti o shock termici, si può danneggiare irrimediabilmente il sensore.                  At temperatures above 400°C avoid hard knocks or thermal shocks which could cause irremediable damages.                  A température supérieure aux 400°C éviter les coups violents et les chocs thermiques qui pourraient abimer irremédiablement le capteur.                  Vermeide man heftige Stöße, besonders bei Temperaturen über 400°C, oder Temperaturschocks um die Fühler nicht wiedergutzumachernde Weise beschädigen können.                  Cuando las temperaturas son mayores que 400°C evitar golpes fuertes y los cambios bruscos de temperatura que pueden ocasionar danos irremediables el la sonda</p>							