

Part Number: 2MLBP-1

Type	Size	Rating	Description
Neon	4mm	-	Standard Brightness Bi-pin Neon Lamp

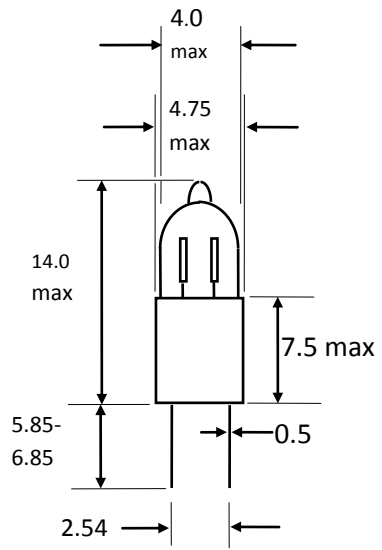

Dimensions in millimetres

Notes:

- 1 **Base Type** White Bi-pin, Tinned leadwires
- 2 **Nominal mA** 0.4
- 3 **Strike Voltage** 95VAC max.
- 4 **Lamp Marking** Unmarked
- 5 **Environmental** RoHS & REACH SVHC compliant