

THIS DRAWING IS UNPUBLISHED. RELEASED FOR PUBLICATION  
 © COPYRIGHT - By - ALL RIGHTS RESERVED.

LOC	DIST	REVISIONS					
		P	LTR	DESCRIPTION	DATE	DWN	APVD
AF	50		M1	REVISED PER ECO-11-004917	11MAR11	RK	HMR

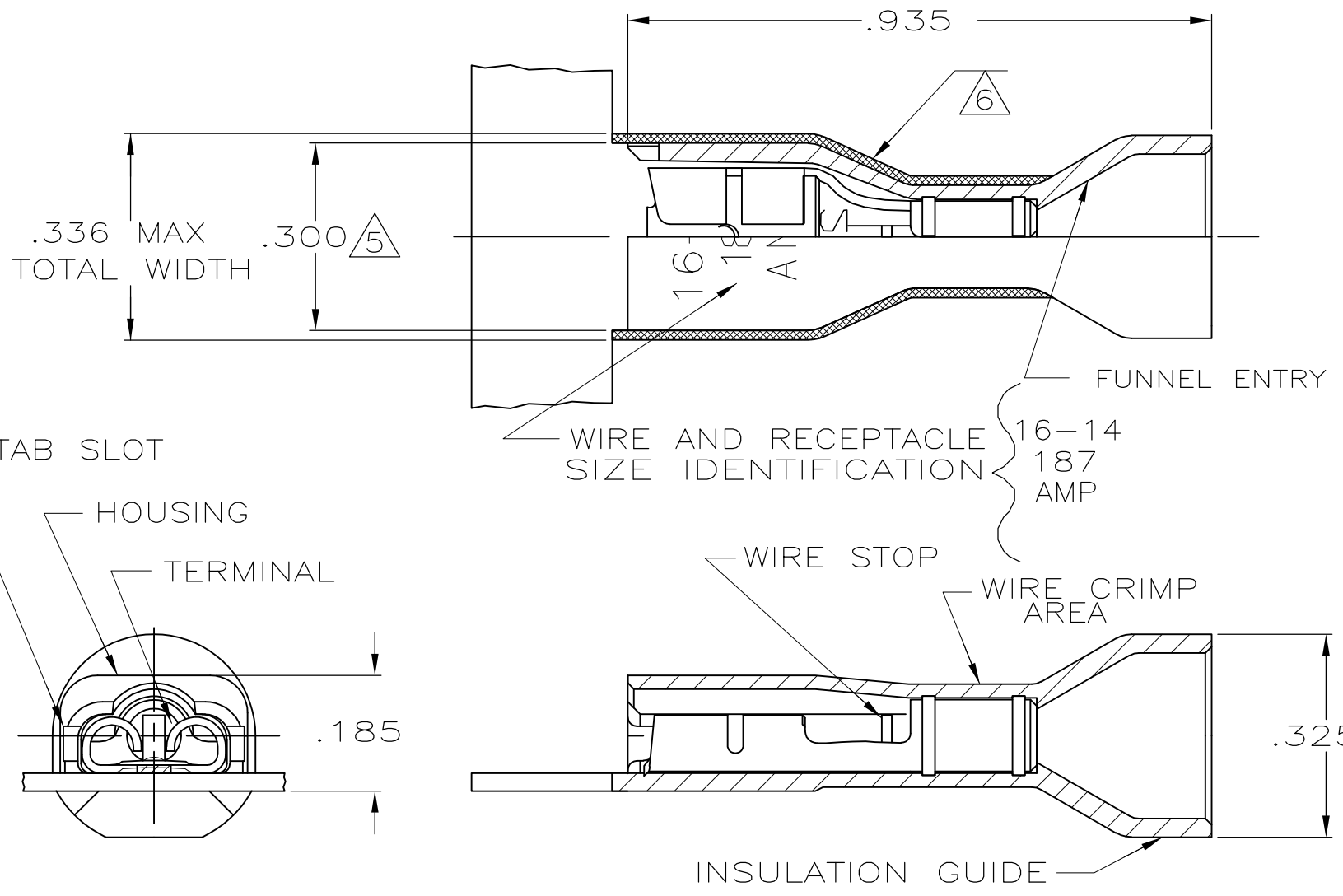

- 1 MATES WITH .020±.001x.187 TAB
- 2 WIRE STRIP LENGTH .281
- 3 INSULATION SIZE .260 MAX DIA
- 4 CONTINUOUS STRIP ON REELS
- △5 DIMENSION DOES NOT INCLUDE TRIM BURR
- △6 .015 MAX CARRIER TRIM BURR PER SIDE IS ALLOWABLE IN THE SHADED AREA
- △7 PRELIMINARY - NOT FOR PRODUCTION

STANDARD	HOUSING:NYLON,COLOR-GRAY TRANSLUCENT RECEPTACLE:#3 HARD BRASS TIN PL .000080 MIN THK	△7 6-520150-2
BULK	HOUSING:NYLON,COLOR-BLUE TRANSLUCENT RECEPTACLE:#3 HARD BRASS TIN PL .000080 MIN THK	5-520150-2
STANDARD		3-520150-2
PACKAGING	MATERIAL & FINISH	PART NO

THIS DRAWING IS A CONTROLLED DOCUMENT.		DWN P FORTNEY 9/28/88	<b>TE Connectivity</b>		
DIMENSIONS: INCHES		CHK MS FEHER 9/28/88			NAME RECEPTACLE ASSY,ULTRA-FAST, .187 SERIES,16-14 AWG
		APVD K RANDOLPH 9/28/88			
TOLERANCES UNLESS OTHERWISE SPECIFIED:		PRODUCT SPEC 108-2043	RESTRICTED TO		
MATERIAL SEE TABLE		FINISH SEE TABLE	APPLICATION SPEC 114-2123	SIZE A3	
		WEIGHT -	CAGE CODE 00779	DRAWING NO C-520150	
CUSTOMER DRAWING			SCALE 4:1	SHEET 1 OF 1	
			REV M1		