

|     |                   |
|-----|-------------------|
| REV | HDP24-24* * P/S * |
| H   |                   |

| REVISIONS |                         |         |          |
|-----------|-------------------------|---------|----------|
| SYM       | DESCRIPTION             | DATE    | APPROVED |
| E         | REVISED PER E.O. P17811 | 7/24/02 | R.D.R.   |
| F         | REVISED PER E.O. P18119 | 4/14/03 | R.D.R.   |
| G         | REVISED PER E.O. P18449 | 2/4/04  | R.D.R.   |
| H         | REVISED PER E.O. P21391 | 6-15-12 | RDR      |

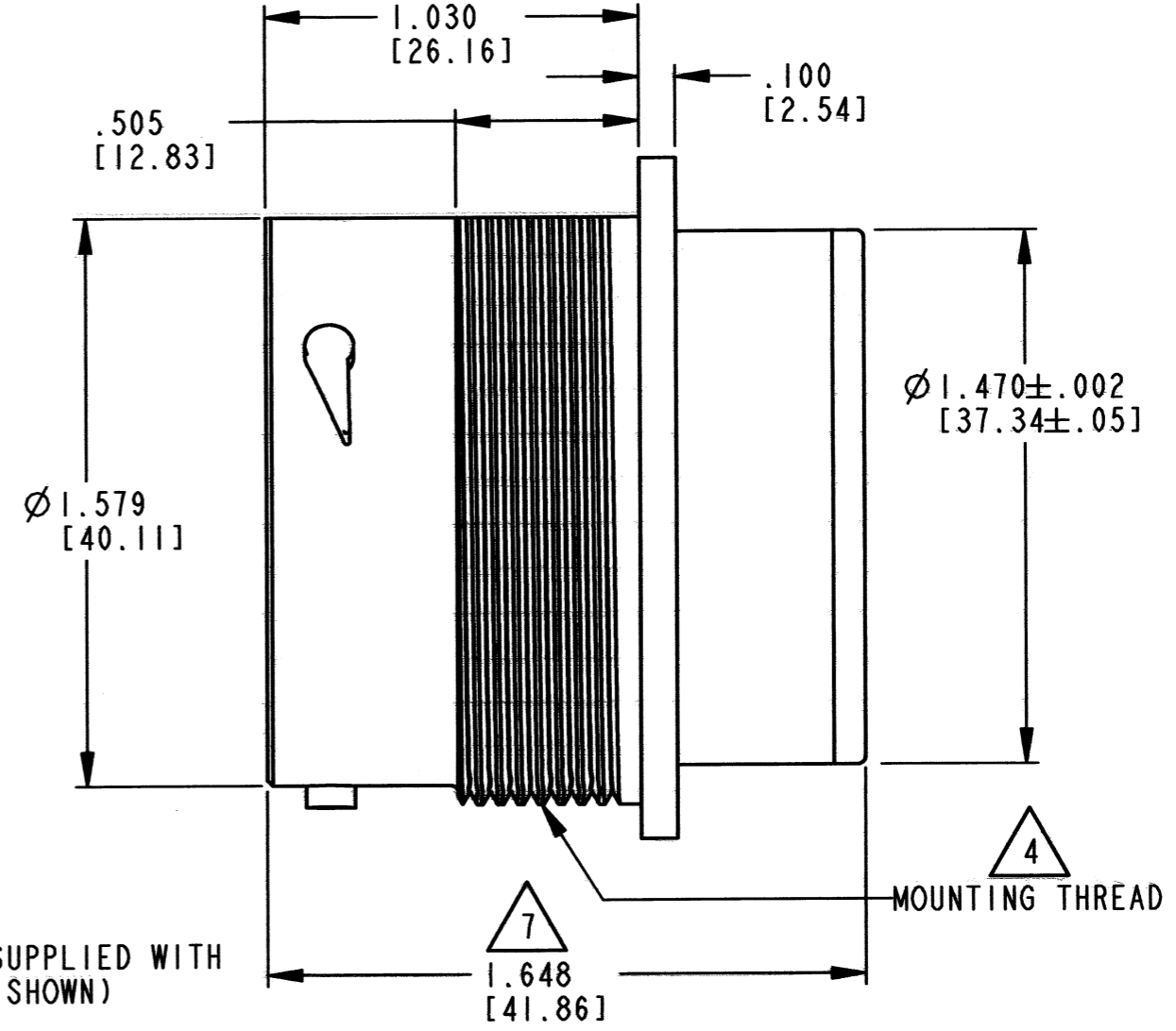
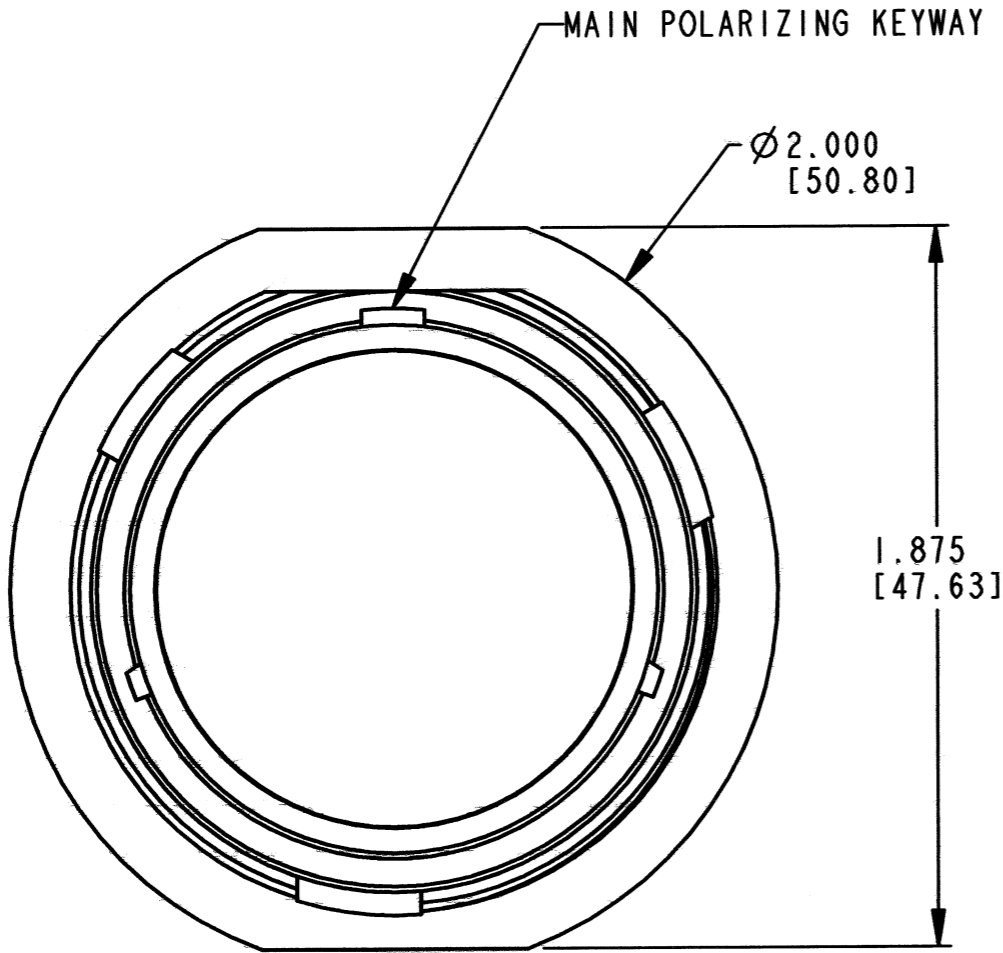

- 7. TOTAL DIMENSION WITH EXTENDED WIRE SEAL (WITH CONTACTS #4 OR #8 ONLY) IS 1.910 ± .025 [48.51 ± .63].
- 6. FOR ARRANGEMENT OF CONTACT LOCATION SEE ENVELOPE DRAWING 0425-014-2400.
- 5. FOR CONTACTS AND WIRES PERFORMANCE APPLICATION CHARACTERISTICS SEE ENVELOPE DRAWING 0425-015-0000.
- 4. FOR PERFORMANCE, MOUNTING AND APPLICATION CHARACTERISTICS SEE ENVELOPE DRAWING 0425-021-0000.
- 3. DIMENSIONS ARE IN INCHES [MILLIMETERS].
- 2. RECOMMENDED PANEL THICKNESS: .062[1.58] TO .187[4.76].
- 1. THIS RECEPTACLE TO BE USED WITH 2411-001-2405 (PLASTIC) PANEL NUT AND 2414-001-2486 LOCK WASHER.

- 10. RECEPTACLE IS SUPPLIED WITH DUST CAP. (NOT SHOWN)
- 9. DIMENSION TOLERANCES ARE ±.025 [±.63] UNLESS OTHERWISE NOTED.
- 8. THIS PART MATES WITH HDP26-24-\*\*\*S/P\*-\*\*\*\* (\*\*\*\*=ALL MODIFICATIONS) \* = TYPE OF SEAL.

|                  |                  |
|------------------|------------------|
| SIGNATURE & DATE |                  |
| DR               | S. BEARD 03MAR00 |
| CHK              | S. Beard 6/15/12 |
| PE               | S. Beard 6/15/12 |
| APPD             | S. Beard 6/15/12 |
| SCALE            | NONE             |
| WT               |                  |

RECEPTACLE CONNECTOR  
SHELL SIZE 24  
BAYONET COUPLING  
HDP20 SERIES

ENVELOPE

|   |                       |
|---|-----------------------|
| EP                                      | MATL. CODE            |
| 3850 INDUSTRIAL AVE.<br>HEMET, CA 92545 |                       |
| <b>B</b> HDP24-24 * * P/S *             |                       |
| DWG SIZE                                | CODE 11139 SHEET   OF |