

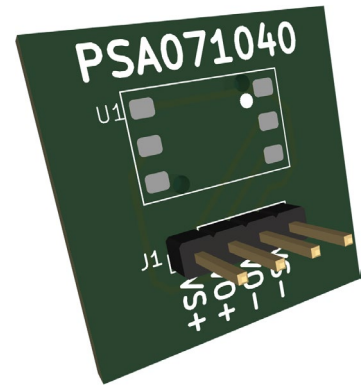

PUIaudio



Data Sheet	PSA070140-EB Demonstration Board
------------	----------------------------------

PUI Audio's PSA070140-EB pressure sensor demonstration board features the PUI Audio PSA070140 analog output gauge pressure sensor. The PSA070140 features a -40kPa to 40kPa input pressure range.

The PSA070140 features a high-linearity pressure sensor that is factory calibrated.

The board features a small size of 23.0mm x 23.0mm, 4.7V to 5.5V power supply voltage range, and header pins for easy design prototype development.

Features:

- -40kPa to 40kPa input pressure range
- Gauge sensor
- 5.0VDC nominal power supply voltage
- Board's dimensions: 23.0mm x 23.0mm

Electrical Characteristics

Absolute Maximum Ratings ($T_A = 25^\circ\text{C}$, unless otherwise specified.)

Parameter	Conditions	Minimum	Typical	Maximum	Unit
V_{DD}		-0.3		15	Volts
Output Pins		-0.3		$V_{DD}+0.3$	Volts
Burst Pressure				400	kPa
ESD Class	Human Body Model	-2000		2000	Volts
Storage Temperature		-40		125	$^\circ\text{C}$

Performance Characteristics ($V_{DD} = 5.0\text{V}\pm 0.005$, $T_A = 25\pm 1^\circ\text{C}$, $\text{RH} = 50\pm 10\%$)

Parameters	Conditions	Minimum	Typical	Maximum	Unit
V_{DD}		4.7	5.0	5.3	Volts
I_{DD}			1.0	2.0	mA
Operating Temperature		-20		85	$^\circ\text{C}$
Pressure Characteristics					
Pressure Range		-40		40	kPa
Full-Scale Output Voltage		60	75	90	mV
Linearity	$-40^\circ\text{C} \leq T_A \leq 85^\circ\text{C}$	-0.3	± 0.1	0.3	%FS
Hysteresis ¹		-0.2		0.2	%FS
Repeatability ²		-0.3	± 0.15	0.3	%FS
Overload Pressure	Maximum continuous applied pressure			80	kPa
Output Offset ³	Gauge Pressure = 0Pa	-20		20	mV
Output Offset Temperature Coefficient ⁴			80		$\mu\text{V}/^\circ\text{C}$
Full-Scale Pressure Temperature Drift Coefficient ⁵	$0^\circ\text{C} \leq T_A \leq 50^\circ\text{C}$	-0.03		0.03	%FS/ $^\circ\text{C}$
	$-20^\circ\text{C} \leq T_A \leq 85^\circ\text{C}$		-0.19		

Note 1: Operating conditions include a 5V power supply voltage and 25°C ambient temperature applied for 60 minutes. The pressure is then changed. The sensor's output is observed for 30 minutes. Hysteresis is the difference between the maximum and the minimum value divided by the full-scale output.

Note 2: An original pressure is applied, and the output voltage value is measured. The pressure is changed to a different value and the output voltage is measured. The pressure applied is returned to the original value and the output voltage is measured. The difference in the output voltage when evaluating the original pressure is the Repeatability.

Note 3: This refers to the gauge pressure 0Pa, the immediate atmospheric pressure value present around the PSA071040.

Note 4: The Output Offset varies with temperature. With $V_{DD} = 5.0\text{V}\pm 0.005$, assign ten pressures evenly throughout the PSA071040 input pressure range. At each pressure, measure the output voltage at each of the following temperatures: -20°C , 0°C , 25°C , 45°C , 65°C , 85°C . Log the voltage and resistance for each pressure and temperature combination. Calculate the sensitivity, the linearity, and the output offset.

Note 5: Use a constant voltage supply source, $V_{DD} = 5.0\text{V}\pm 0.005$. The current drawn is adaptive.

PSA070140 Digital Output Pressure Sensor Pin Descriptions

Pin Definitions

PIN	1	2	3	4	5	6
Pin Definition 1	V ₀ ⁻	V _S ⁺	V ₀ ⁺	NC	GND	V ₀ ⁻
Pin Definition 2	GND	V ₀ ⁺	V _S ⁺	NC	V ₀ ⁻	GND

Signal Definitions

Symbol	V _S ⁺	GND	V ₀ ⁺	V ₀ ⁻
Pin Definition	Positive Power Supply Voltage	Power Supply Ground	Positive Analog Output Voltage, Referenced to GND	Analog Output Voltage GND Reference

Typical Output Voltage vs. Pressure (V_{DD} = 5.0V±0.005, T_A = 25±1°C, RH = 50±10%)

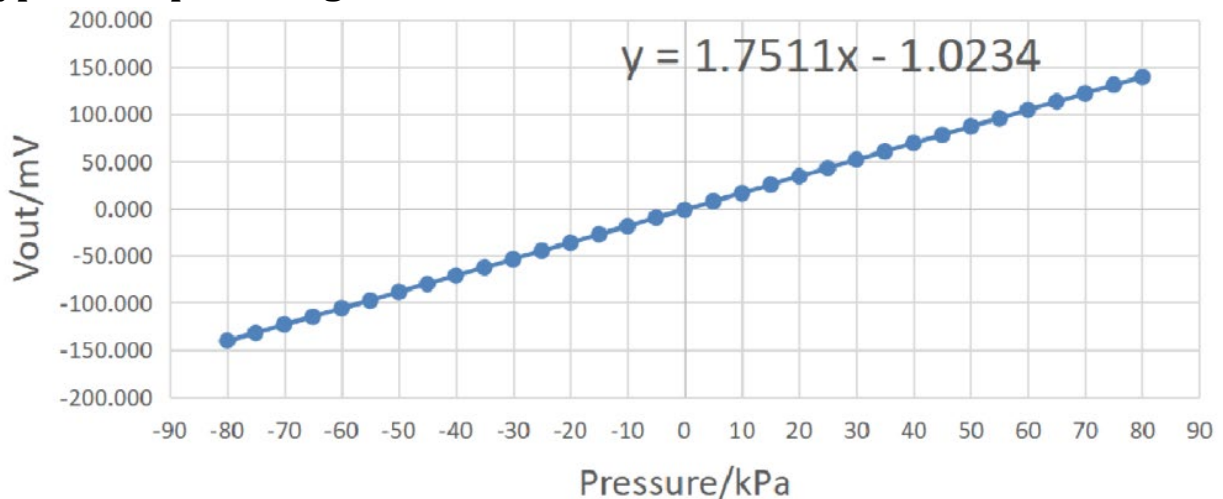

Pressure Performance Curve

With respect to the curve titled “Typical Output Voltage vs. Pressure,” the following is an explanation of how the output can be a negative voltage while operating on a single supply referenced to ground when a negative pressure (partial vacuum) is applied. Referring to Figure 1, the power supply voltage is applied to Pin 3, Pins 1 and 6 are connected to ground, Pin 2 is the positive output, and Pin 5 is the negative output. When a positive pressure is applied to the sensor, the output voltage at Pin 2 (V_{OUT+}) is higher than the voltage present at Pin 5 (V_{OUT-}) and the differential voltage [V_{OUT+} - V_{OUT-}] is greater than 0V. Conversely, a negative pressure input creates a higher voltage at Pin 5 that is higher than the voltage at Pin 2 and the differential voltage is less than 0V.

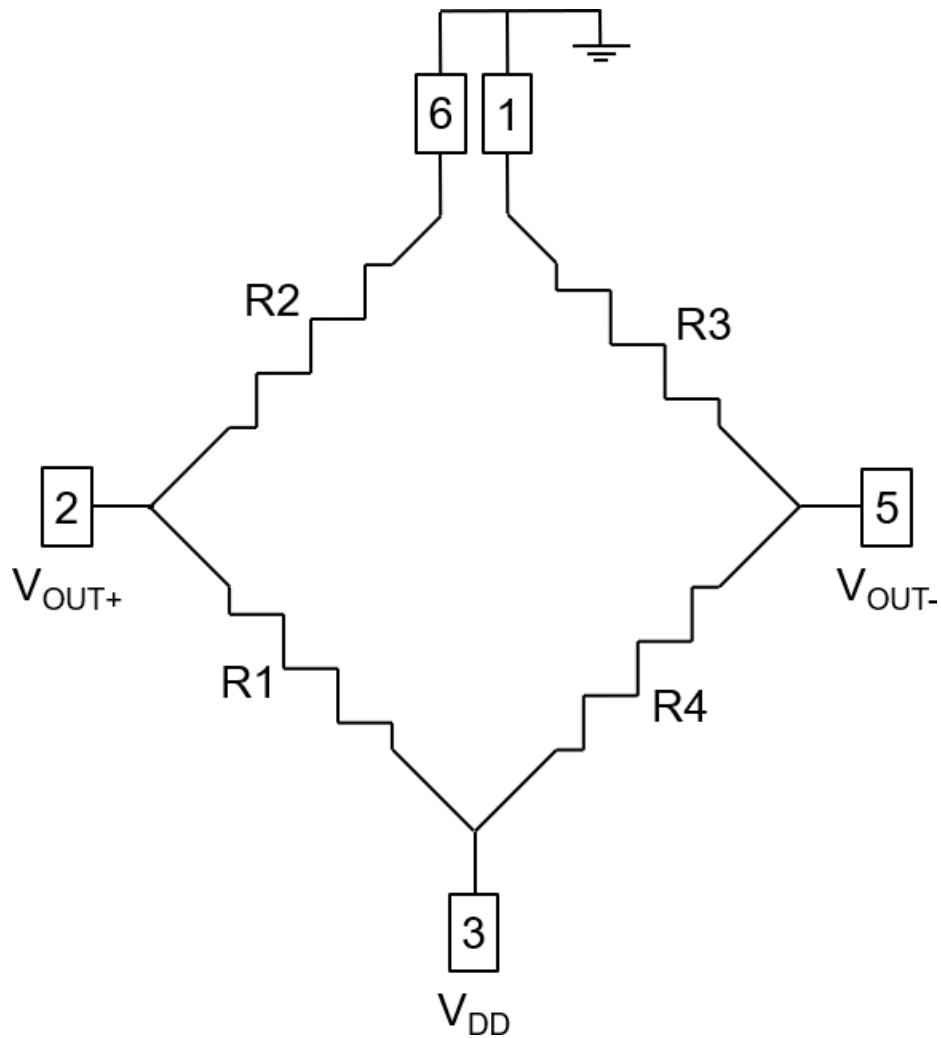

Figure 1. PSA070140 block diagram.

Circuit Description

Referring to Figure 2, the PSA070140-EB is designed for a nominal supply 5V power supply voltage, applied through connector J1's pin 1 and GND on J1's pin 4. The gauge sensor's output is found between J1's pin 2 and J1's pin 3.

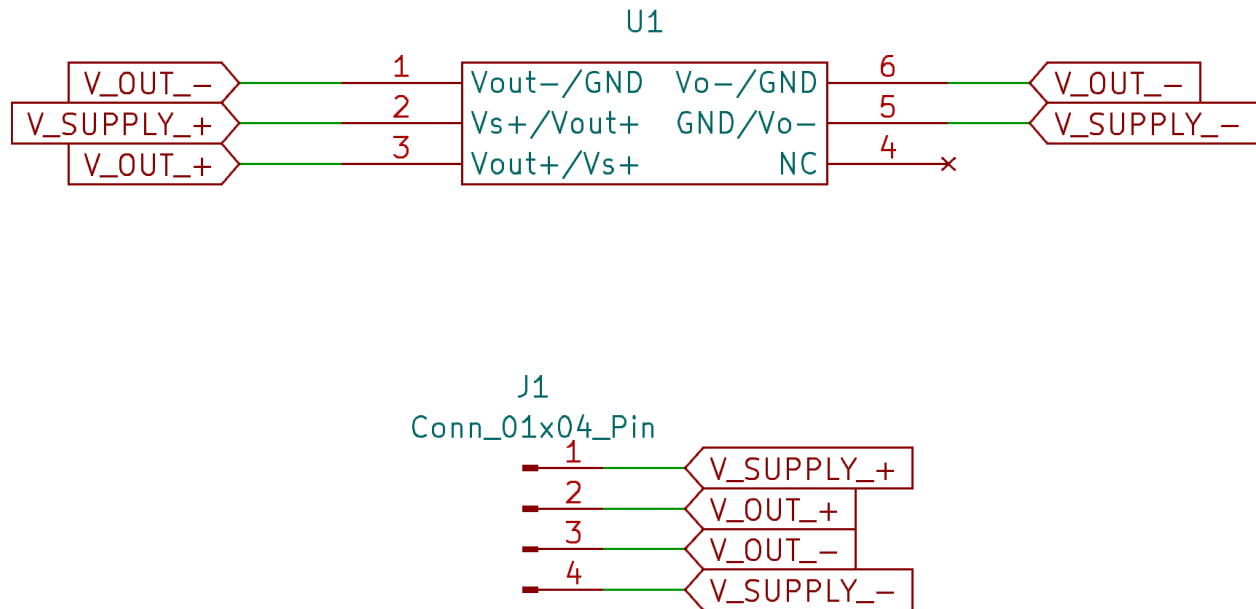
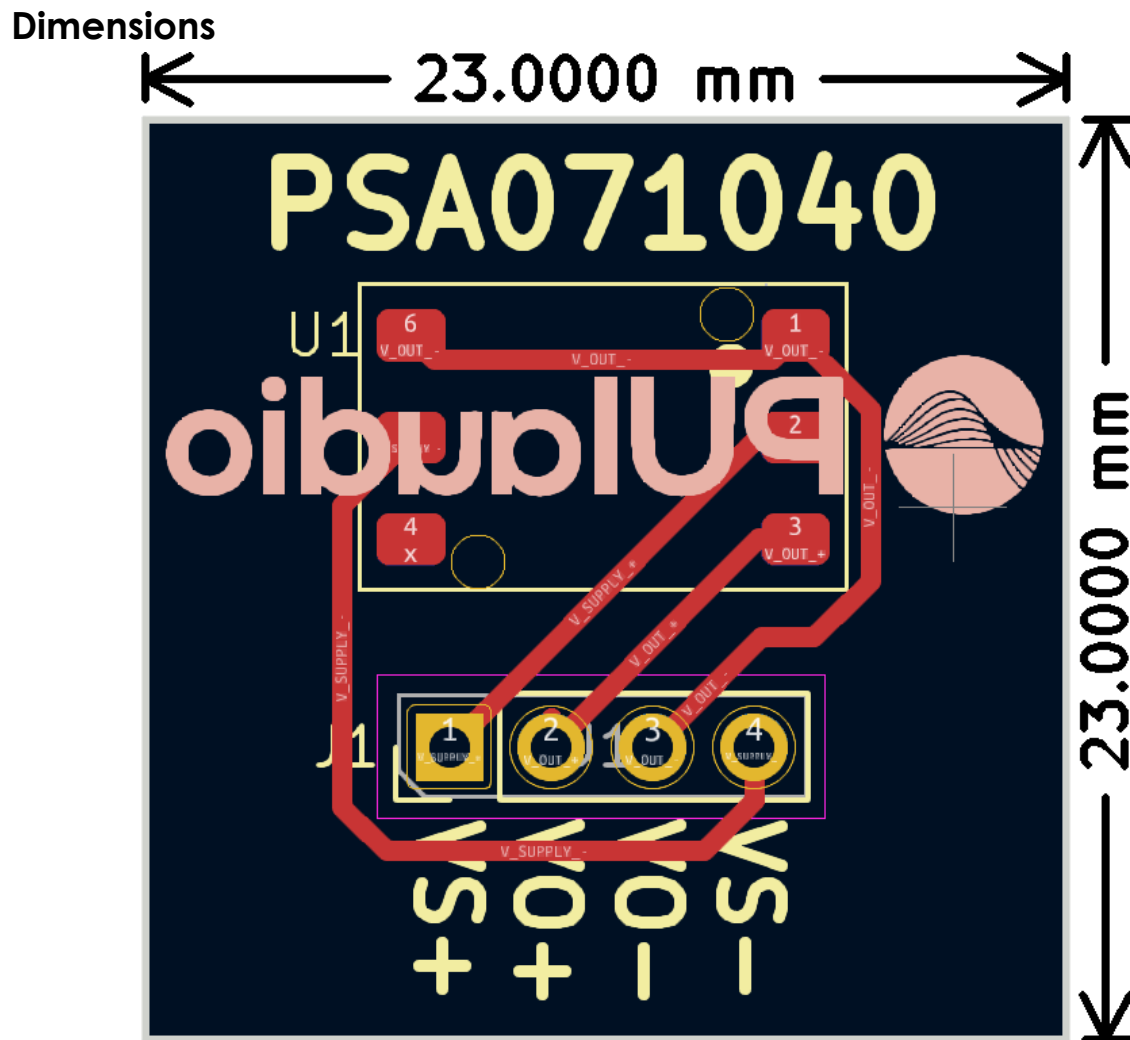
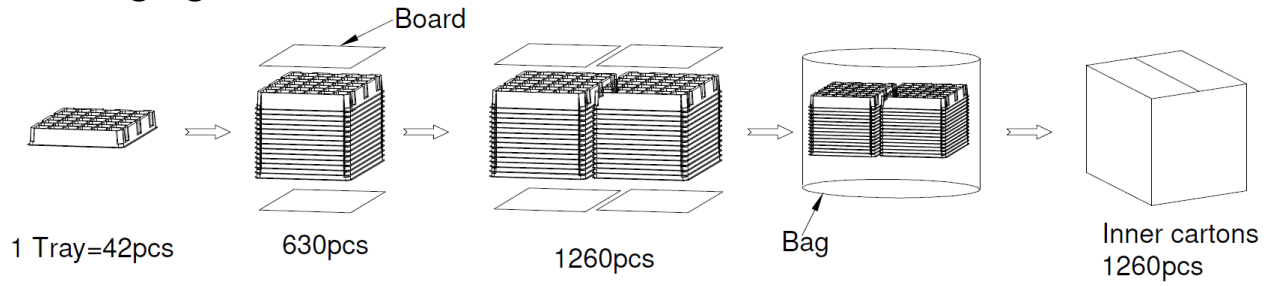

Figure 2. PSA070140-EB schematic.



Packaging



Specifications Revisions

Revision	Description	Date	Approved
A	Datasheet released from Engineering	10/07/2025	KH

Note:

1. Unless otherwise specified:
 - A. All dimensions are in millimeters.
 - B. Default tolerances are $\pm 0.5\text{mm}$ and angles are $\pm 3^\circ$, unless otherwise specified.
2. Specifications subject to change or withdrawal without notice.