

- PARTS PACKAGED UNASSEMBLED AS A UNIT KIT.
- CABLE CLAMP HALVES: BLACK ABS MOLDING COMPOUND, FILLISTER HEAD SCREWS, HEX NUTS & MOUNTING SCREWS: STEEL PER ASTM A108, GROMMETS: FLEXIBLE PVC, UL 94V-0 RATED, COLOR: BLACK.
- CABLE CLAMP HALVES: NICKEL OVER COPPER, FILLISTER HEAD SCREWS, HEX NUTS & MOUNTING SCREWS: ZINC PLATED .000200-.000400 THICK, CLEAR CHROMATE COATING.
- SIZE 3 CONFIGURATION SHOWN. NUMBER AND SIZE OF SLOTS IN THIS AREA VARIES BY CABLE CLAMP SIZE.

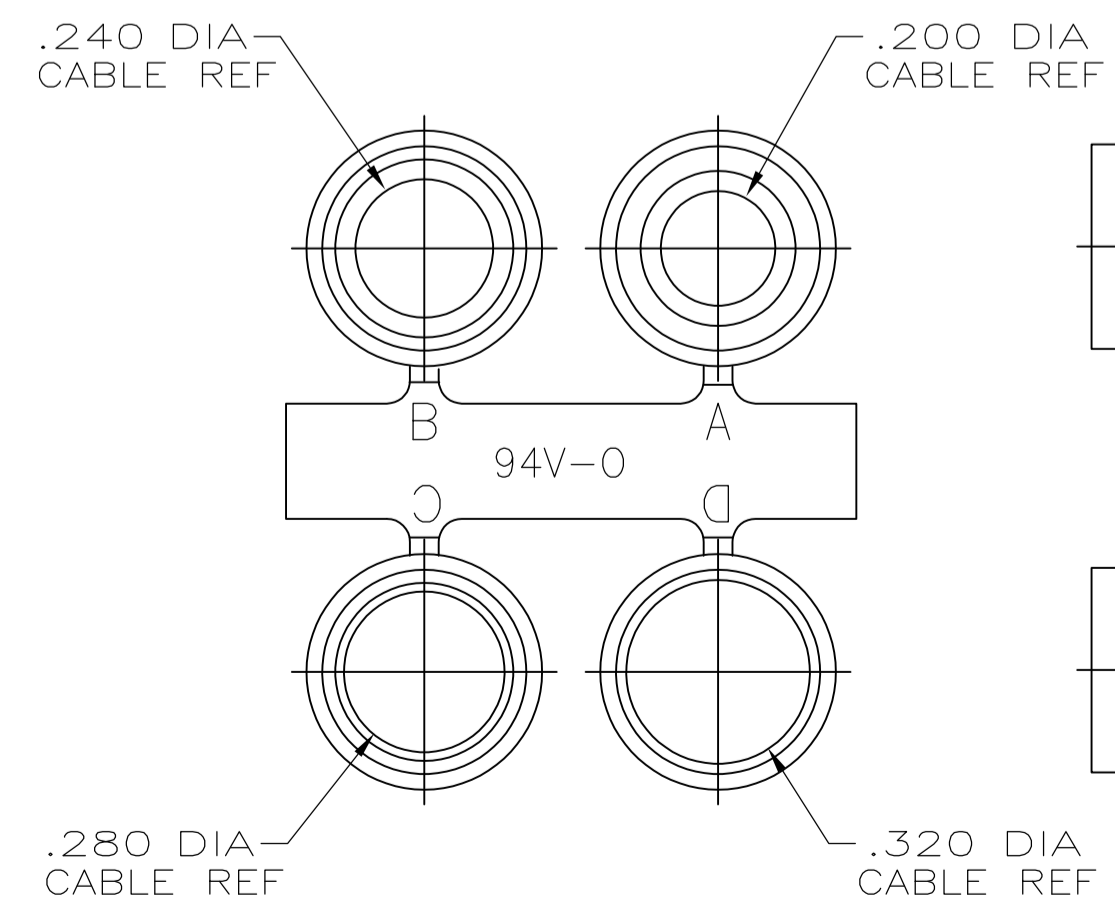

GROMMET ASSORTMENT FOR SIZES 1 & 2 ONLY

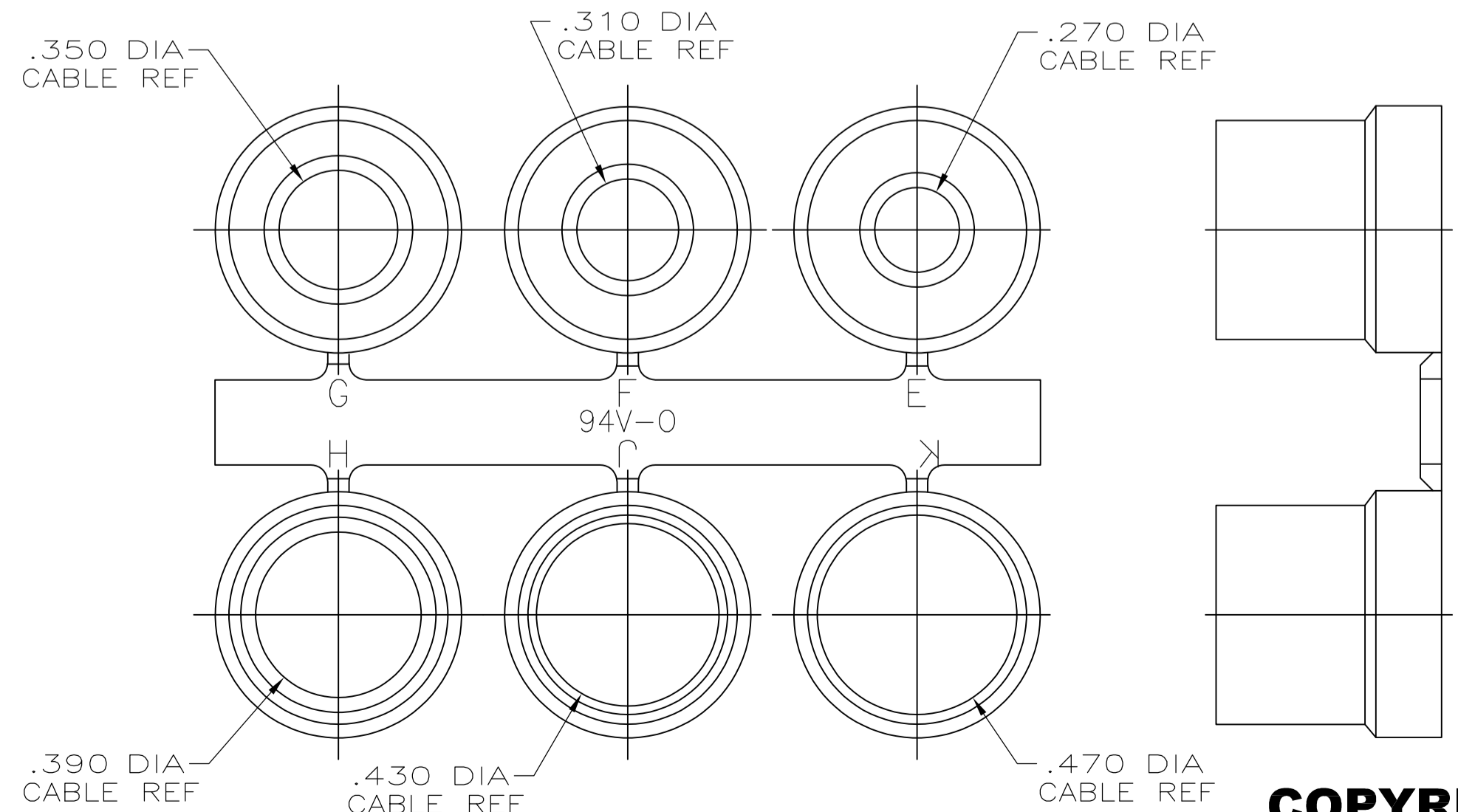

GROMMET ASSORTMENT FOR SIZES 3, 4 & 5 ONLY

.900	.730	2.644	1.920	2.406	5	5748677-5
.800	.620	2.738	1.920	2.500	4	5748677-4
.680	.640	2.090	1.920	1.852	3	5748677-3
.620	.620	1.545	1.910	1.312	2	5748677-2
.570	.630	1.215	1.910	.984	1	5748677-1
E	D	C	B	A	SIZE	PART NO

THIS DRAWING IS A CONTROLLED DOCUMENT.

DIMENSIONS: INCHES	TOLERANCES UNLESS OTHERWISE SPECIFIED:	0 PLC ± -	1 PLC ± -	2 PLC ± -	3 PLC ± .005	4 PLC ± -	ANGLES ± -
MATERIAL	FINISH	WEIGHT	SIZE	CAGE CODE	DRAWING NO	RESTRICTED TO	
			A1	-	5748677		

D. HENNY 8-18-05
 C. ROHDE 8-18-05
 M. WALMSLEY 8-18-05
 Tyco Electronics Corporation Harrisburg, Pa 17105-3608
 KIT, CABLE CLAMP, 180° EXIT, W/GROMMETS AMPLITE SERIES, PLATED PLASTIC
 SCALE 3:1 SHEET 1 OF 1 REV A

COPYRIGHT 2005 TYCO ELECTRONICS CORP ALL RIGHTS RESERVED