

DESCRIPTION CONTROL			
REV	DESC	DATE	ECN NO.

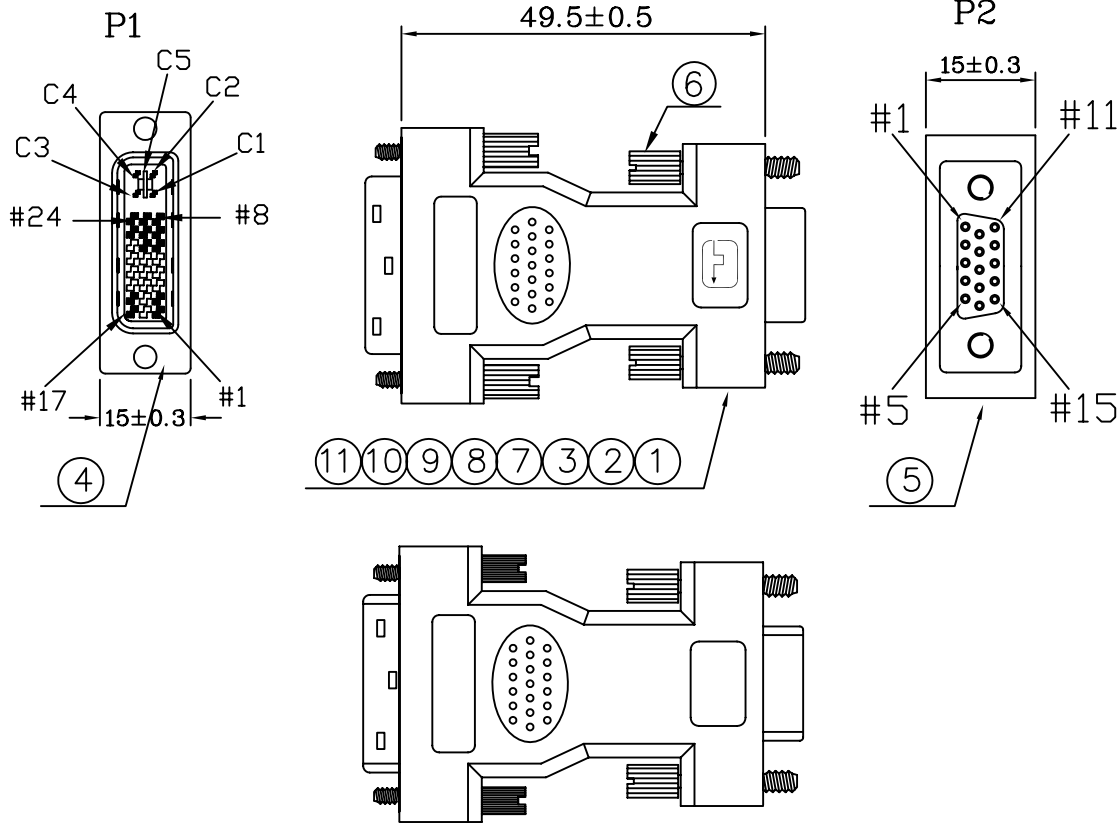

PIN ASSIGNMENT

P1	P2
C1	1
C2	2
C3	3
C4	13
C5	6+7+8
6	15
7	12
8	14
14+16	9
15	5+10
S	S

RoHS COMPLIANT

*	370	CARTON:46*30*25CM	1/500	PCS				
*	370	PE BAG:10"*12"*0.06MM	1/50	PCS	OUTER MOLDING	GC/HD15-DVI091		
*	370	PE-BAG:3.5"*3.5"*0.06MM	1	PCS	INNER MOLDING	GC/HD15-DVI092		
8	370	PVC-BLACK10/50	19	G				
7	370	PE-5321	10.5	G				
6	240010700068	SRW-14.7*22.6MM	4	PCS				
5	104-1520120010-C	CDS-H15S<BLACK>	1	PCS		ITEM: 489349	REV	
4	204-1251101200-C	DVI-12+4+KEY-M<BLACK>	1	PCS			R	
3	370	FOIL-CU-41MM	85	MM	DRAW, BY: 楊燕瑛	SCALE: NONE	DATE: 2007/12/04	
2	100500126021	JUMP WIRE-26-1007	4*(2*25*2)	MM	CHECK, BY:	CUSTOMER: C331(RS)	PAGE: 1/1	
1	100500128003	JUMP WIRE-28-1007	10*(2*50*2)	MM	APP, BY:	CUSTOMER P/N: 489349		
NO	TYPE	DESCRIPTION	QTY	UNIT	ALL DIMENSIONS IN mm			