

MAGNETIC CATCH S

Article Nr. 21.0888/0

[See the product on the website](#) →

[Download CAD Files](#) →

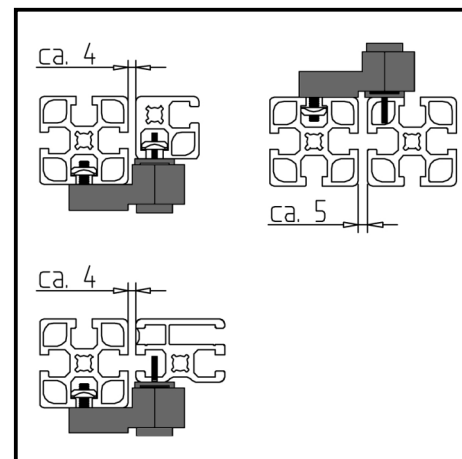
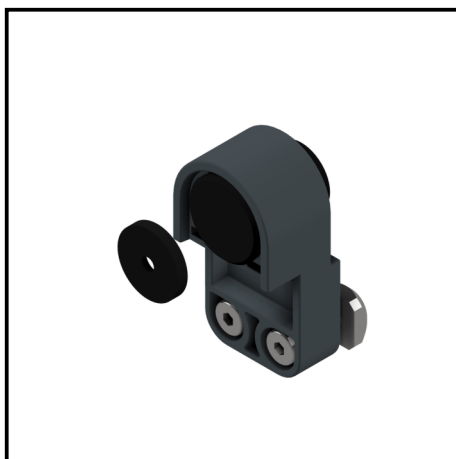
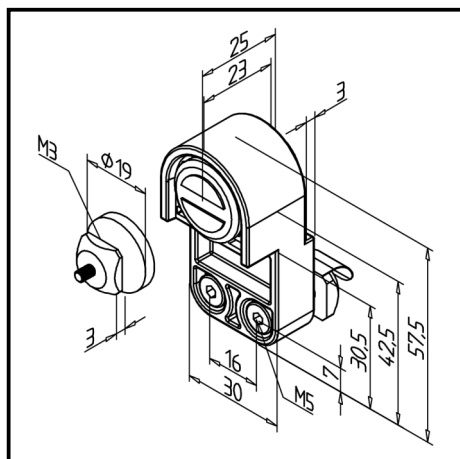

TECHN. DATA / ITEMS SUPPLIED

- ABS, Injection Mould, grey
- Holder plate steel, burnished
- With fastening material steel, zinc plated
- Holding force approx. 70 N
- Weight = 0.075 kg/piece

APPLICATIONS

- Stop and quick-release of swing doors
- Fastening of light surface elements

ASSEMBLY

- Fasten with fixing material to profile groove
- Fit retaining plate with fastening kit in profile groove or directly on profile surface; to do so, cut thread M3