

Verwendbar mit Flachstecker 0.8mm und 0.6mm Dicke
USABLE WITH TAB 0.8mm AND TAB 0.6mm THICKNESS

Kontakte fuer FLR-Leitung
CONTACTS FOR FLR-CABLE

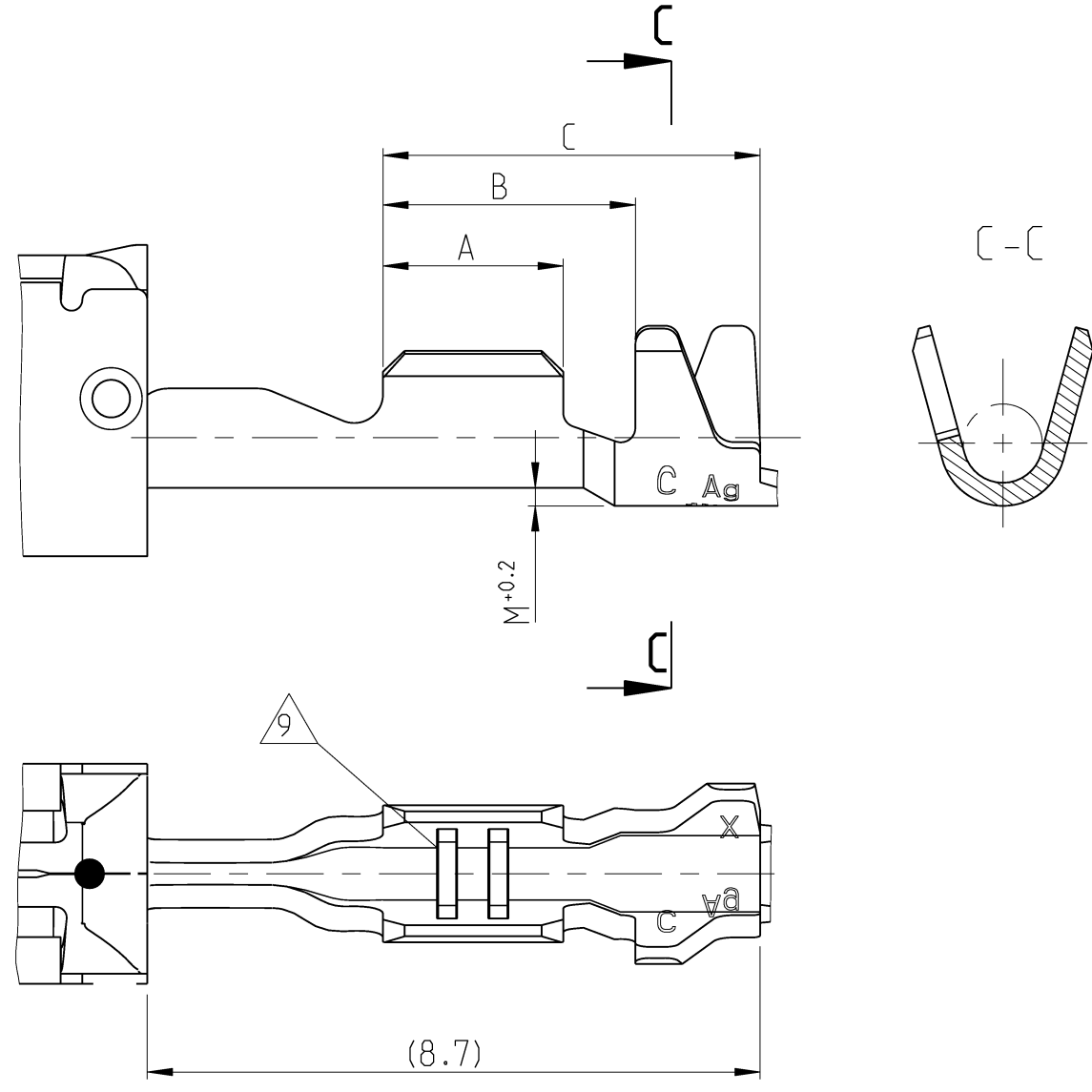
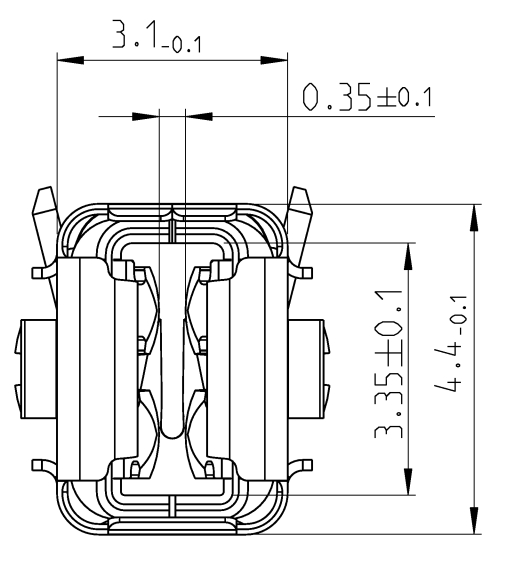
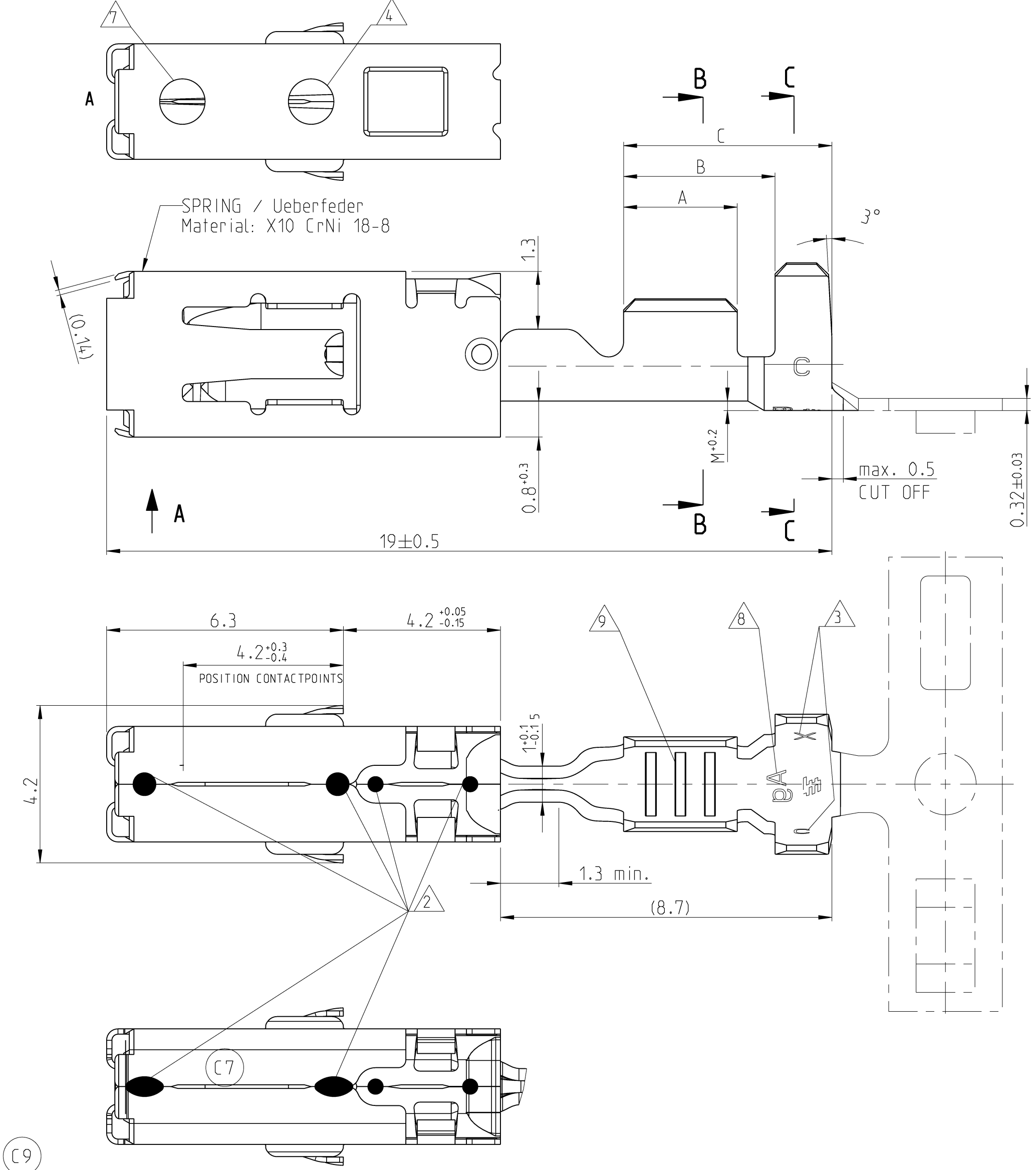

TYPE A

TYPE B

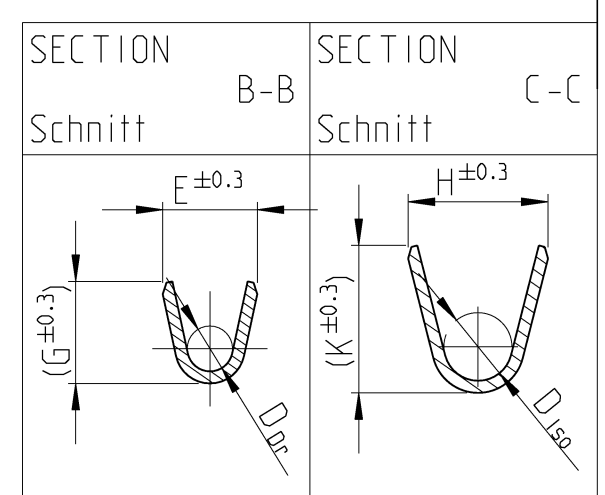

Kontakte fuer Einzel-Dichtung-System: FLR- und FLK-Leitung
CONTACTS FOR SINGLE WIRE SEALING SYSTEM: FLR- AND FLK- CABLE

Masse siehe Darstellung der Kontakte fuer FLR-Leitung
DIMENSIONS SEE FIGURE "CONTACTS FOR FLR-CABLE"

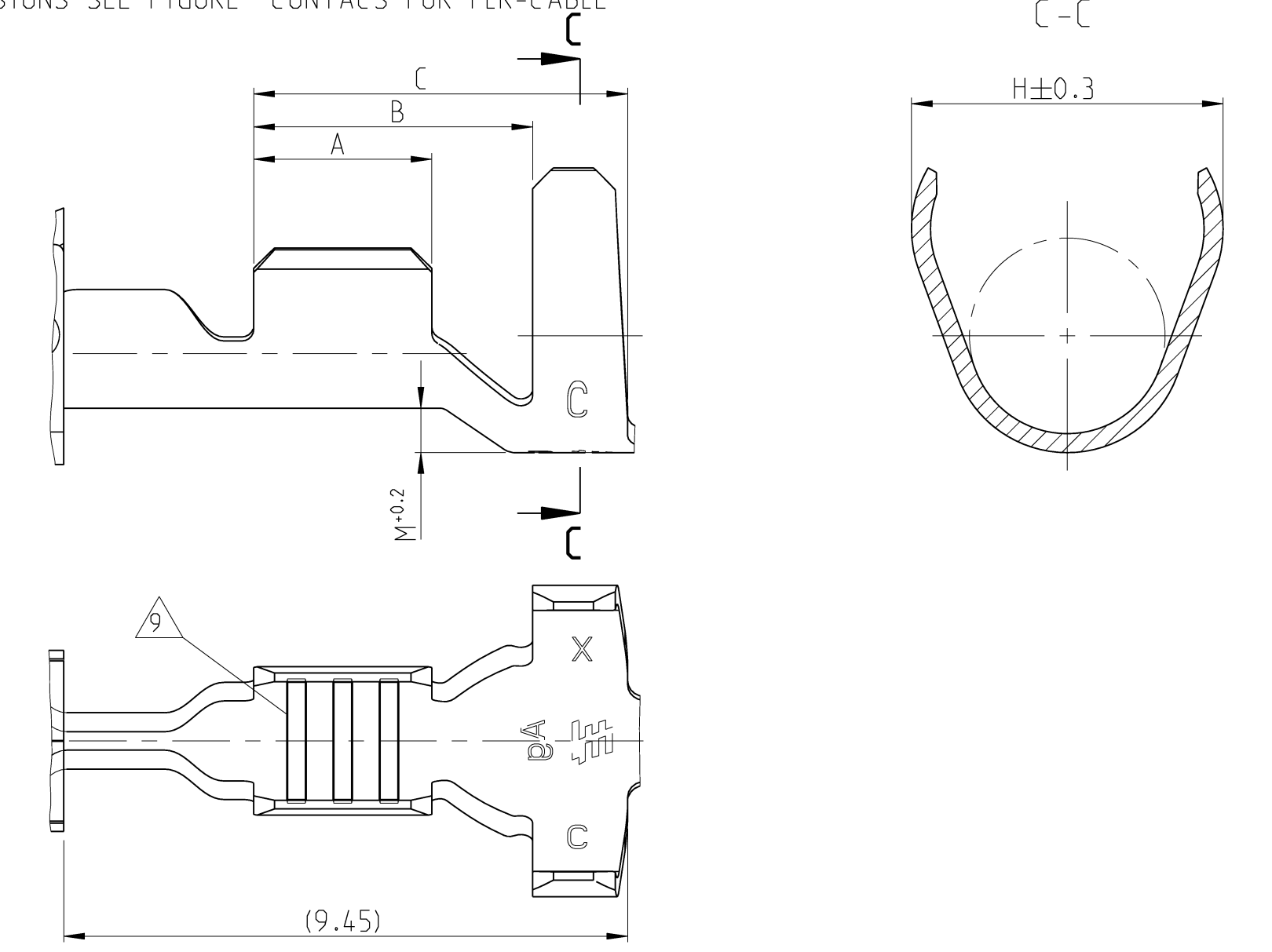

SINGLE WIRE SEALING SYSTEM

963292-1	2.7...3.0	YELLOW gelb
963293-1	2.0...2.7	REDBROWN rotbraun
963294-1	1.2...2.1	BLUE blau
ORDER NO. Bestell-Nr.	INSULATION DIA Isolations Ø	COLOUR Farbe

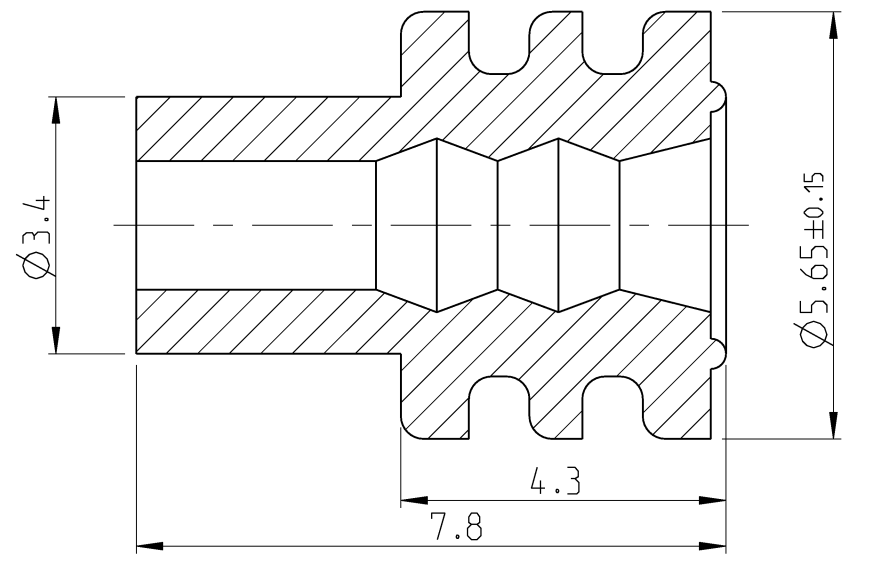

ORDER NO. Bestell-Nr.	REV.	ORDER NO. Loose Piece Einzelausfuehrung	WIRE RANGE Drahtgroessenbereich (mm ²)	INSULATION DIA Isolations Ø (mm)	MATERIAL Werkstoff	PLATING Ueberzug	LENGTH Laenge	WIRE CRIMP Drahtcrimp	INSUL. CRIMP Isol.-Crimp	FORM OF ISO-CRIMP Form des Iso-Crimp	ORDER NO. Bestell-Nr. TOOL / INSERT Handzange / Matrize	ORDER NO. Bestell-Nr. EXTRACTION TOOL Ausdrueckwerkzeug	CRIMP DATA AND CRIMP TOOL Crimpdaten u. Crimpwerkzeuge	
2-1241396-3	C	2-1241397-3	>1.0-2.5	2.2-3.0	CuNiSi	PRESILVER vorversilbert	A = 3.5 B = 5.2 C = 6.8	E = 3.6 G = 3.8 D _{cr} = 1.8	H = 5.45 K = (4.8) D _{iso} = 3.5 M = 0.85	TYPE A	HANDCRIMP TOOL Handcrimpwerkzeug 539635-1	INSERT / Matrize 539952-2	539969-1	SEE APPLICATION SPECIFICATION siehe Verarbeitungsspezifikation 114-18387
0-1241396-3	C	0-1241397-3			CuNiSi	PRESILVER vorversilbert				TYPE B	HANDCRIMP TOOL Handcrimpwerkzeug 539635-1	INSERT 4-1579016-1		
0-1241396-2	C	0-1241397-2			CuNiSi	TINPLATED vorverzinkt				TYPE A	HANDCRIMP TOOL Handcrimpwerkzeug 539635-1	INSERT / Matrize 539951-2		
0-1241396-1	C	0-1241397-1			CuNiSi	PRESILVER vorversilbert	A = 3.0 B = 4.7 C = 6.3	E = 2.5 G = 2.7 D _{cr} = 1.2	H = 5.25 K = (4.8) D _{iso} = 3.3 M = 0.75	TYPE A	HANDCRIMP TOOL Handcrimpwerkzeug 539635-1	INSERT / Matrize 539951-2		
0-1241394-3	C	0-1241395-3	0.5-1.0	1.4-2.7	CuNiSi	PRESILVER vorversilbert	A = 2.5 B = 4.7 C = 6.3	E = 2.4 G = 2.3 D _{cr} = 1.0	H = 4.85 K = (4.4) D _{iso} = 3.2 M = 0.7	TYPE B	HANDCRIMP TOOL Handcrimpwerkzeug 539635-1	INSERT 4-1579016-1		
0-1241394-2	C	0-1241395-2			CuNiSi	TINPLATED vorverzinkt				TYPE A	HANDCRIMP TOOL Handcrimpwerkzeug 539635-1	INSERT / Matrize 539951-2		
0-1241394-1	C	0-1241395-1			CuNiSi	PRESILVER vorversilbert	A = 3.3 B = 4.3 C = 5.8	E = 3.6 G = 3.8 D _{cr} = 1.8	H = 4.7 K = (4.9) D _{iso} = 2.6 M = 0.4	TYPE A	HANDCRIMP TOOL Handcrimpwerkzeug 539635-1	INSERT / Matrize 539951-2		
0-1241392-3	C	0-1241393-3	0.2-0.35	1.1-1.4	CuNiSi	TINPLATED vorverzinkt				TYPE B	HANDCRIMP TOOL Handcrimpwerkzeug 539635-1	INSERT 4-1579016-1		
0-1241392-2	C	0-1241393-2			CuNiSi	PRESILVER vorversilbert	A = 3.0 B = 4.0 C = 5.5	E = 2.5 G = 2.7 D _{cr} = 1.2	H = 3.7 K = (3.9) D _{iso} = 1.8 M = 0.2	TYPE A	HANDCRIMP TOOL Handcrimpwerkzeug 539635-1	INSERT / Matrize 539951-2		
0-1241392-1	C	0-1241393-1			CuNiSi	TINPLATED vorverzinkt				TYPE B	HANDCRIMP TOOL Handcrimpwerkzeug 539635-1	INSERT 4-1579016-1		
0-1564984-3	C	0-1564985-3	0.2-0.35	1.1-1.4	CuNiSi	PRESILVER vorversilbert	A = 2.5 B = 3.5 C = 5.2	E = 2.4 G = 2.3 D _{cr} = 1.0	H = 2.5 K = (2.5) D _{iso} = 1.1 M = 0.2	TYPE B	HANDCRIMP TOOL Handcrimpwerkzeug 539635-1	INSERT 4-1579016-1		
0-1564984-2	C	0-1564985-2			CuNiSi	TINPLATED vorverzinkt				TYPE A	HANDCRIMP TOOL Handcrimpwerkzeug 539635-1	INSERT / Matrize 539951-2		
0-1564984-1	C	0-1564985-1			CuNiSi	PRESILVER vorversilbert				TYPE B	HANDCRIMP TOOL Handcrimpwerkzeug 539635-1	INSERT 4-1579016-1		
0-1241390-3	C	0-1241391-3	>1.0-2.5	2.2-3.0	CuNiSi	PRESILVER vorversilbert				TYPE A	HANDCRIMP TOOL Handcrimpwerkzeug 539635-1	INSERT / Matrize 539951-2		
0-1241390-2	C	0-1241391-2			CuNiSi	TINPLATED vorverzinkt				TYPE B	HANDCRIMP TOOL Handcrimpwerkzeug 539635-1	INSERT / Matrize 539951-2		
0-1241390-1	C	0-1241391-1			CuNiSi	PRESILVER vorversilbert				TYPE A	HANDCRIMP TOOL Handcrimpwerkzeug 539635-1	INSERT / Matrize 539951-2		
0-1241388-3	C	0-1241389-3	0.5-1.0	1.4-2.1	CuNiSi	TINPLATED vorverzinkt				TYPE B	HANDCRIMP TOOL Handcrimpwerkzeug 539635-1	INSERT / Matrize 539951-2		
0-1241388-2	C	0-1241389-2			CuNiSi	PRESILVER vorversilbert				TYPE A	HANDCRIMP TOOL Handcrimpwerkzeug 539635-1	INSERT / Matrize 539951-2		
0-1241388-1	C	0-1241389-1			CuNiSi	TINPLATED vorverzinkt				TYPE B	HANDCRIMP TOOL Handcrimpwerkzeug 539635-1	INSERT / Matrize 539951-2		
0-1241386-3	C	0-1241387-3	0.2-0.35	1.1-1.4	CuNiSi	PRESILVER vorversilbert				TYPE A	HANDCRIMP TOOL Handcrimpwerkzeug 539635-1	INSERT / Matrize 539951-2		
0-1241386-2	C	0-1241387-2			CuNiSi	TINPLATED vorverzinkt				TYPE B	HANDCRIMP TOOL Handcrimpwerkzeug 539635-1	INSERT / Matrize 539951-2		
0-1241386-1	C	0-1241387-1			CuNiSi	PRESILVER vorversilbert				TYPE A	HANDCRIMP TOOL Handcrimpwerkzeug 539635-1	INSERT / Matrize 539951-2		
0-1564982-3	C	0-1564983-3	0.2-0.35	1.1-1.4	CuNiSi	TINPLATED vorverzinkt				TYPE B	HANDCRIMP TOOL Handcrimpwerkzeug 539635-1	INSERT / Matrize 539951-2		
0-1564982-2	C	0-1564983-2			CuNiSi	PRESILVER vorversilbert				TYPE A	HANDCRIMP TOOL Handcrimpwerkzeug 539635-1	INSERT / Matrize 539951-2		
0-1564982-1	C	0-1564983-1			CuNiSi	TINPLATED vorverzinkt				TYPE B	HANDCRIMP TOOL Handcrimpwerkzeug 539635-1	INSERT / Matrize 539951-2		

Bemerkungen
NOTES

- Geeignet fuer Flachstecker / TAB 2.8 -0.3 x 0.8 ±0.03
TO BE USED ON Flachstecker / TAB 2.8 -0.3 x 0.6 -0.03
- Laserschweissung wahlweise Punk- oder Linienfoermig (DIE CAUSED)
ALTERNATIVELY LASERWELDED POINT OR LINE SHAPED (FERTIGUNGSBEDINGT)
- Kenntnis fuer Werkzeug und Revisionsstand
DIE-IDENTIFICATION AND REVISION STATUS
- 0.8µm Goldueberzug im Kontaktbereich ueber min. 1.3µm Nickelueberzug.
Zur Kennzeichnung siehe Loch an der Ueberfeder.
MIN. 0.8µm GOLDPLATE IN CONTACT AREA OVER MIN. 1.3µm NICKELPLATE.
MIN. 1µm TINPLATE IN CRIMP AREA.
AS INDEX SEE HOLE AT SPRING
- Fuer Doppel- und Einzelcrimp
FOR DOUBLE AND SINGLE CRIMP
- Auswahl der Einzeldichtung entsprechend dem Isolationsdurchmesser
SINGLE WIRE SEAL TO BE SELECTED ACCORDING TO INSULATION-DIA
- Fertigungsbedingtes Loch, befindet sich ab Rev. C an allen Kontakten
MANUFACTURER-CONDITIONED HOLE, IS STARTING FROM REV. C AT ALL VERSIONS
- Kennzeichnung mit "Ag" bei Silberueberzug im Kontaktbereich
MARKING WITH "Ag" FOR SILVERPLATE IN CONTACT AREA
- Unterschiedliche Ausfuehrung der Rillen moeglich
DIFFERENT FORM OF THE SERRATION POSSIBLE
- PN 1241386 und 1241392 nicht fuer Neuanwendung, Ersatz durch PN 1564982 und 1564984
PN 1241386 AND 1241392 NOT FOR NEW APPLICATION, REPLACED BY PN 1564982 AND PN1564984.
- Einzelheiten der Ausfuehrung bleiben dem Hersteller ueberlassen
DETAILS OF DESIGN ARE LEFT TO MANUFACTURER
- Fertigteil an den Kontaktpunkten geschmiert
FINISHED PRODUCT AT CONTACT POINTS LUBRICATED

THIS DRAWING IS A CONTROLLED DOCUMENT. DWG No. 06JUN2006
DATE OF REVISION: 06 JUN 2006
OTHER THAN SPECIFIED: ALTERNATIVE UNLESS OTHERWISE SPECIFIED: ALTERNATIVE UNLESS OTHERWISE SPECIFIED

0 PLC	±	GENERAL	±	PRODUCT SPEC	108-18717
1 PLC	±	TOLERANCE	±	APPLICATION SPEC	114-18387
2 PLC	±	FINISH	±	WEIGHT	-
3 PLC	±	FINISH	±	CUSTOMER DRAWING	-
4 PLC	±	FINISH	±	SCALE	10:1
5 PLC	±	FINISH	±	SHEET	1 OF 1

PRODUCT GROUP DRAWING FOR AMP MCP 2.8K
DRAWING NO. 1241437
SHEET 1 OF 1